

Welding Booth

Two (2) 8" to One (1) 12"

Notes:

1. Connect to 12" K&B
2. Galvanized Steel

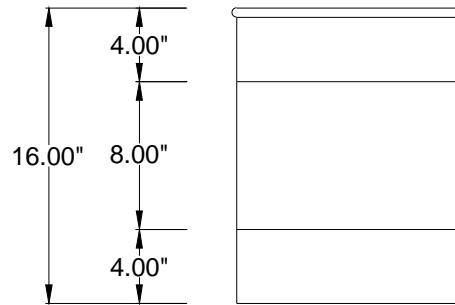

Right View

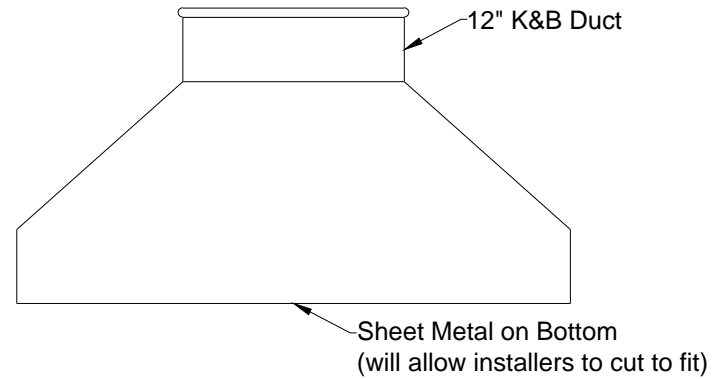

Side View

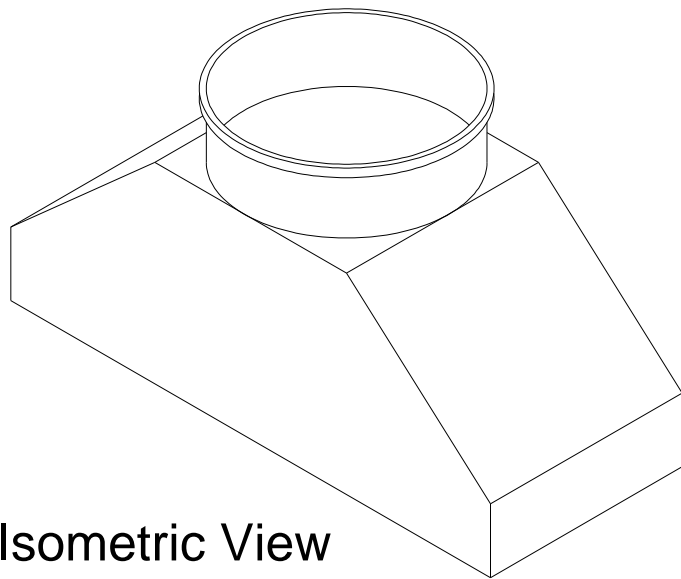

Isometric View

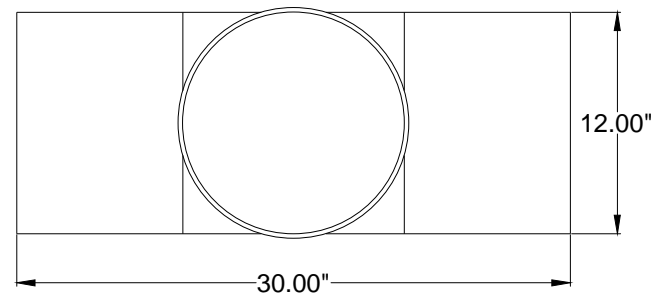

Top View

Avani Environmental Intl.
 95 Cypress Drive
 Youngsville, NC 27596
 P# 919-570-2862 F# 919-570-2863

Avani

Project: Welding Booth Transition

Drawing: (2) 8" to (1) 12"

Date: 10/31/12

Drawn by: MDT

Sheet No: 1 of 1

Rev.: 0