



Date: October 29, 2012

To: Evageline Lousiana Technical College

Project: option#1

Attn:

Recommended Equipment:

- (1) SDC-25-24MDF Cartridge Collector Drawer Type w/ Feet
 - 10,600CFM @ 8" SP
 - normal 12" x 52"L polyester cartridges
- (1) SDC-25x2-32MDF Cartridge Collector Drawer Type w/ Feet
 - 21,200CFM @ 8" SP
 - normal 12" x 52"L polyester cartridges
- (2) SDC-30-24MDF Cartridge Collector Drawer Type w/ Feet
 - 13,000CFM @ 8" SP
 - normal 12" x 52"L polyester cartridges
- (60) WB-1044 w/ ARM-2020
 - J-hooks
 - C clamp

Avani Environmental Intl. Inc.

95 Cypress Drive

Youngsville, NC 27596

www.avanienvironmental.com

Phone: (919) 570-2862

Fax: (919) 570-2863

Email: info@avanienvironmental.com

www.weldingbooths.com

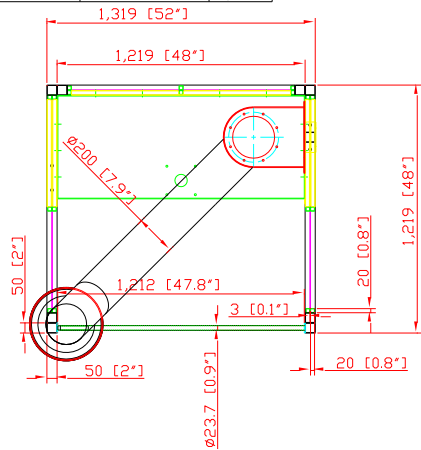

WB-1044 WELDING BOOTH SPECIFICATIONS

- Adjustable Level System: (4) dia. 2.36" Feet
- Panel Construction: 11-gauge welded steel
- Welding Curtain Supports: (1) set welding curtain bar
- Fume Arm Base Supports: (1) to match an optional bracket (6 bolt pattern) and an optional dia. 5" fume arm
- Powder Coated: Avani Safety Blue Standard (custom colors available)
- Three Piece Configuration: (2) side panels, (1) back panel.
- Booths can be mounted back-to-back, side-by-side or both options
- ***Unadjustable Fixed Rear Shelf: 48"W x 20"D x 1.1"H (solid with 2" hole drilled)

OPTIONS

- Welded Nuts: Optional locations for J-Hooks
- Welding Nuts: For wire feeder or welder bracket

OPTIONAL ACCESSORIES:

- Arm 2020: dia. 8" x 7' hanging arm
- BR 008 bracket 008: mounting bracket for dia. 8" fume arm

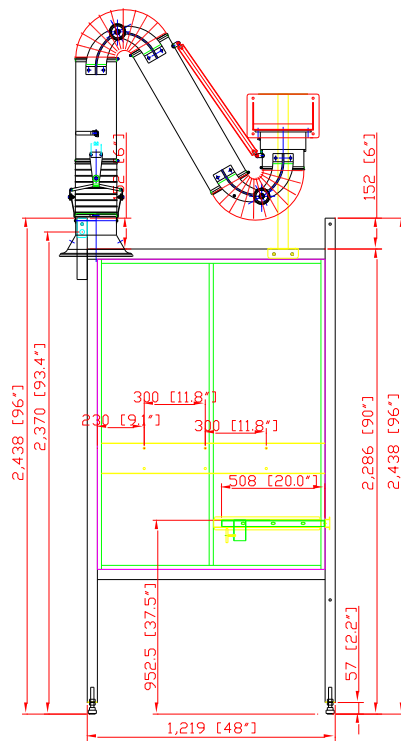
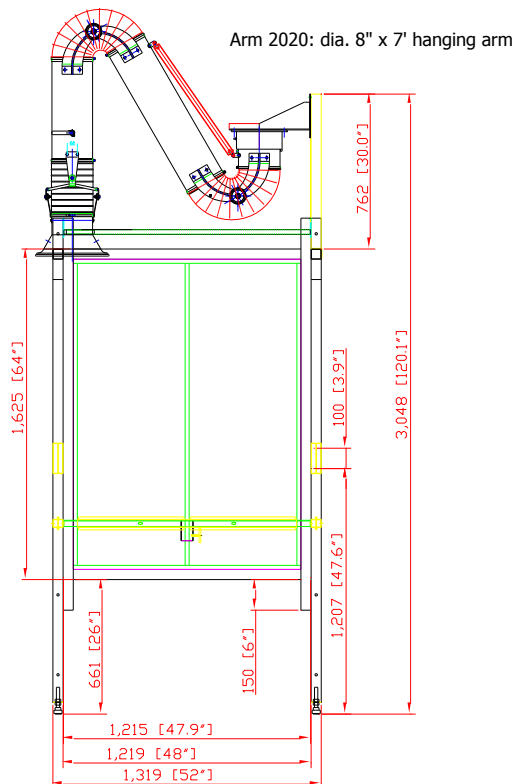

AVANI ENVIRONMENTAL INTL. INC. Sales Department

95 Cypress Drive
Youngsville, NC 27596

(919) 570-2862
info@avanienvironmental.com

Date	Name
2012-10-29	***
Checked by:	

Part Number:
dia. 8" arm

Title:
WB-1044

The drawings, AutoCAD, 3-D Models, and specifications are the property of Avani Environmental Int. Inc. (AE) and may not be reproduced, distributed, modified, or otherwise used, except provided herein, without the express written permission of AE.

Size
Scale
A
1 = 25

Drawing Number:
WB-4x4S

DO NOT SCALE

IF IN DOUBT ASK

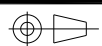

Revisions

Rev	Description	Date	Approved
-----	-------------	------	----------

- SDC-25x2-32MDF SPECIFICATION -

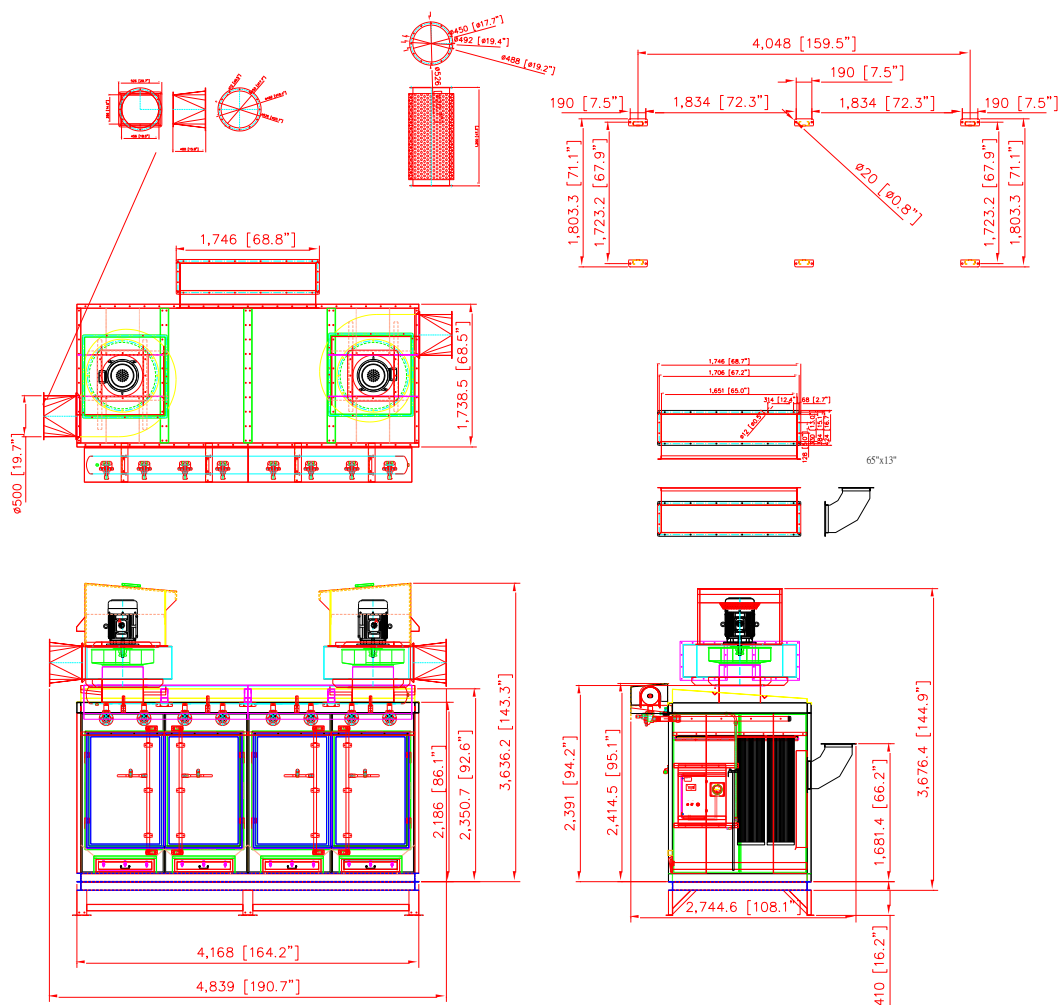

- YTI Direct Drive Blower (on the machine top)
- YTI Motor: 25HP x2 pc
- YTI CFM: 21,200 ft³/min @ 8" SP
- YTI Include:
 - UL Individual Control Boxes for Cartridge Collector and Blowers
- YTI Inlet: 1651 x 330 mm (65" x 13")
- YTI Cartridge Filter: Dia. 325mm x 1320mm x 32pcs (Dia. 12.8" x 52" x 32pcs)
- YTI Material: Polyester with TEFLON coating.
- YTI Filter Area: 19m² x 32 = 608m² (6542.08 ft²)
- YTI Pleat Depth: 48mm
- YTI Horizontal Positioned Filters,
- YTI Continuous Welded Seams,
- YTI Gasket and Latched Doors,
- YTI Powder Coated Paint and
- YTI Reverse Jet Pulse Cleaning
- YTI Include:
 - Filter Chamber
 - Inlet Square Pipe (need dimensions)
 - Fan/motor combinations
- YTI No. of Valves: 8
- YTI Inlet Air: $\frac{3}{4}$ "
- YTI Compressed Air Requirement: 90 PSI
- YTI Compressed Air Reservoir: 31.6 gallon
- YTI Dimension: 190.7" x 108.1" x 144.9" (4839 x 2744.6 x 3676.4mm)
- YTI Construction: 13 Gauge for panel; 11 Gauge Steel Cabinet
- YTI Max. Operating Temp.: 120°C
- YTI Paint Color: Blue

***with Feet underneath the machine.

AVANI ENVIRONMENTAL INTL. INC. Sales Department
95 Cypress Drive
Youngsville, NC 27596

(919) 570-2862
info@avanienvironmental.com

Date	Name	Part Number:	Title:
2012-10-29	***	SDC-25x2-32MDF	Cartridge Collector (drawer type) w Feet
Drawn by:			
Checked by:			
The drawings, AutoCAD, 3-D Models, and specifications are the property of Avani Environmental Intl. Inc. (AE) and may not be reproduced, distributed, modified, or otherwise used, except provided herein, without the express written permission of AE.		Size A	Scale 1 = 1
		Drawing Number: SVL-3200-02	

DO NOT SCALE

IF IN DOUBT ASK

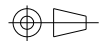

Revisions			
Rev	Description	Date	Approved

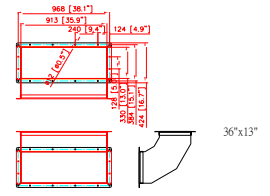
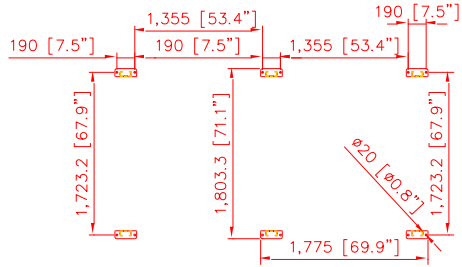
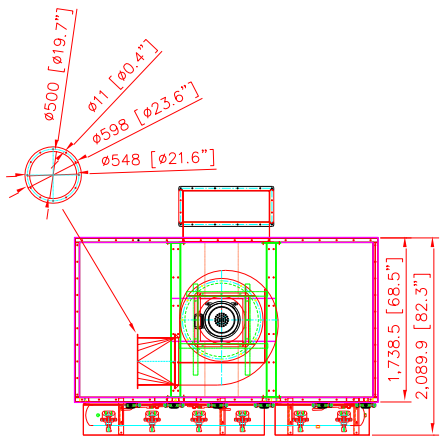

- SDC-25-24MDF SPECIFICATION -

- YI Direct Drive Blower (on the machine top)
- YI Motor: 25HP x 1 pc
- YI CFM: 10,600 ft³/min @ 8" SP
- YI Include:
 - UL Individual Control Boxes for Cartridge Collector and Blowers
- YI Inlet: 913 x 330 mm (36" x 13")
- YI Cartridge Filter: Dia. 325mm x 1320mm x 24pcs (Dia. 12.8" x 52" x 24pcs)
- YI Material: Polyester with TEFLON coating.
- YI Filter Area: 19m² x 24 = 456m² (4906.56 ft²)
- YI Pleat Depth: 48mm
- YI Horizontal Positioned Filters,
- YI Continuous Welded Seams,
- YI Gasket and Latched Doors,
- YI Powder Coated Paint and
- YI Reverse Jet Pulse Cleaning
- YI Include:
 - Filter Chamber
 - Inlet Square Pipe (need dimensions)
 - Fan/motor combinations
- YI No. of Valves: 6
- YI Inlet Air: ³/₄"
- YI Compressed Air Requirement: 90 PSI
- YI Compressed Air Reservoir: 23.7 gallon
- YI Dimension: 133" x 107.9" x 158.4" (3375 x 2739.6 x 4019.1mm)
- YI Construction: 13 Gauge for panel; 11 Gauge Steel Cabinet
- YI Max. Operating Temp.: 120°C
- YI Paint Color: Blue

***with Feet underneath the machine.

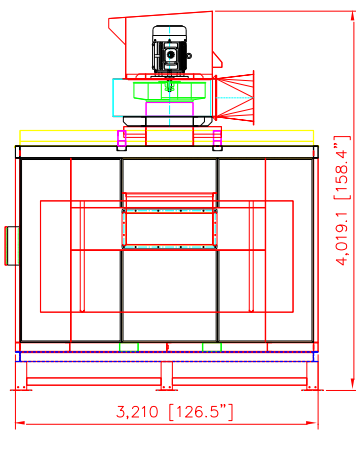
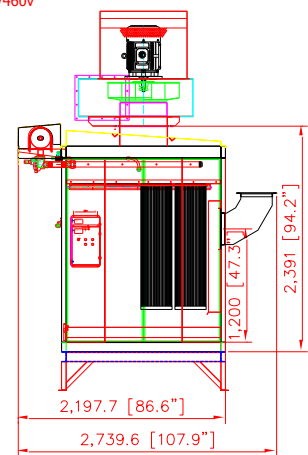
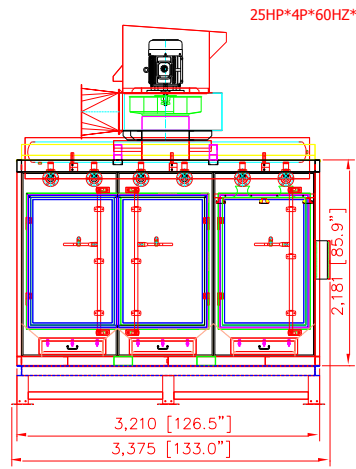

AVANI ENVIRONMENTAL INTL. INC. Sales Department
 95 Cypress Drive (919) 570-2862
 Youngsville, NC 27596 info@avanienvironmental.com

Drawn by:	Date	Name	Part Number: SDC-25-24MDF	Title: Cartridge Collector (drawer type) w Feet
Checked by:	2012-10-29	***		
The drawings, AutoCAD, 3-D Models, and specifications are the property of Avani Environmental Intl. Inc. (AE) and may not be reproduced, distributed, modified, or otherwise used, except provided herein, without the express written permission of AE.			Size A	Scale 1 = 1

Drawing Number:
SVL-2400-02

DO NOT SCALE

IF IN DOUBT ASK



Revisions

Rev	Description	Date	Approved
-----	-------------	------	----------

- SDC-30-24MDF SPECIFICATION -

- Direct Drive Blower (on the machine top)
- Motor: 30HP x 1 pc
- CFM: 13,000 ft3/min @ 8" SP
- Include:
 - UL Individual Control Boxes for Cartridge Collector and Blowers

- Inlet: 913 x 330 mm (35.9" x 13")
- Cartridge Filter: Dia. 325mm x 1320mm x 24pcs (Dia. 12.8" x 52" x 24pcs)
- Material: Polyester with TEFLON coating.
- Filter Area: 19m² x 24 = 456m² (4906.56 ft²)
- Pleat Depth: 48mm

- Horizontal Positioned Filters,
- Continuous Welded Seams,
- Gasket and Latched Doors,
- Powder Coated Paint and
- Reverse Jet Pulse Cleaning
- Include:

- Filter Chamber
- Inlet Square Pipe (need dimensions)
- Fan/motor combinations
- No. of Valves: 6

- Inlet Air: $\frac{3}{4}$ "
- Compressed Air Requirement: 90 PSI
- Compressed Air Reservoir: 23.7 gallon
- Dimension: 130.8" x 107.6" x 158.4" (3320 x 2730.1 x 4019.1mm)
- Construction: 13 Gauge for panel; 11 Gauge Steel Cabinet
- Max. Operating Temp.: 120°C
- Paint Color: Blue

***with Feet underneath the machine.

***Pulse Control Box: run off of 120V / 60Hz/ 1-phase, no transformer inside the pulse box. Pulse Box located outside the building on the collector.

***Blower Control Box 460V / 60Hz / 3-phase, with transformer. Blower box located inside the building.

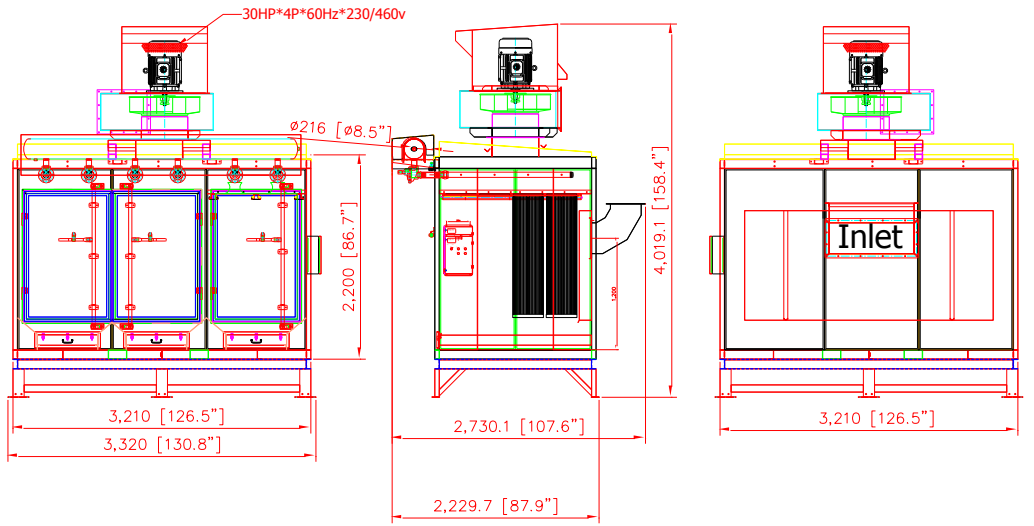
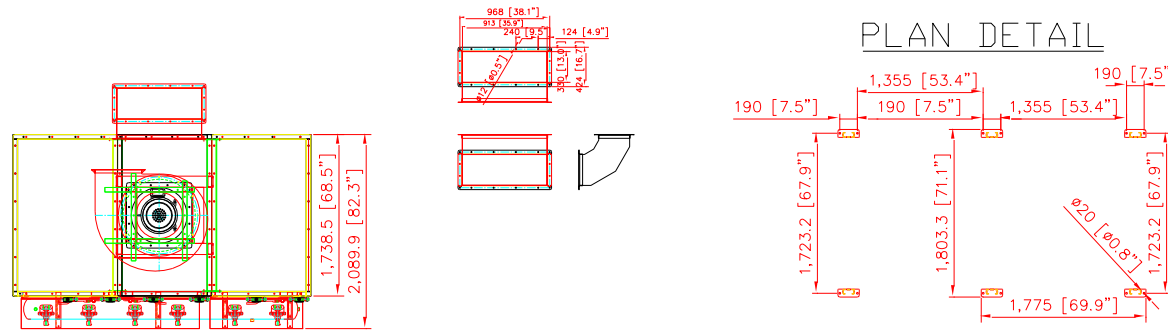

AVANI ENVIRONMENTAL INTL. INC. Sales Department
 95 Cypress Drive
 Youngsville, NC 27596

(919) 570-2862

info@avanienvironmental.com

	Date	Name
Drawn by:	2012-03-17	***
Checked by:	2011-06-28	

Part Number:	SDC-30-24MDF
--------------	--------------

Title:	Cartridge Collector (drawer type) w Feet
--------	--

The drawings, AutoCAD, 3-D Models, and specifications are the property of Avani Environmental Intl. Inc. (AE) and may not be reproduced, distributed, modified, or otherwise used, except provided herein, without the express written permission of AE.

Size	Scale
A	1 = 1

Drawing Number:	SVL-2400-02
-----------------	-------------

WB-1044 w/ ARM-2020

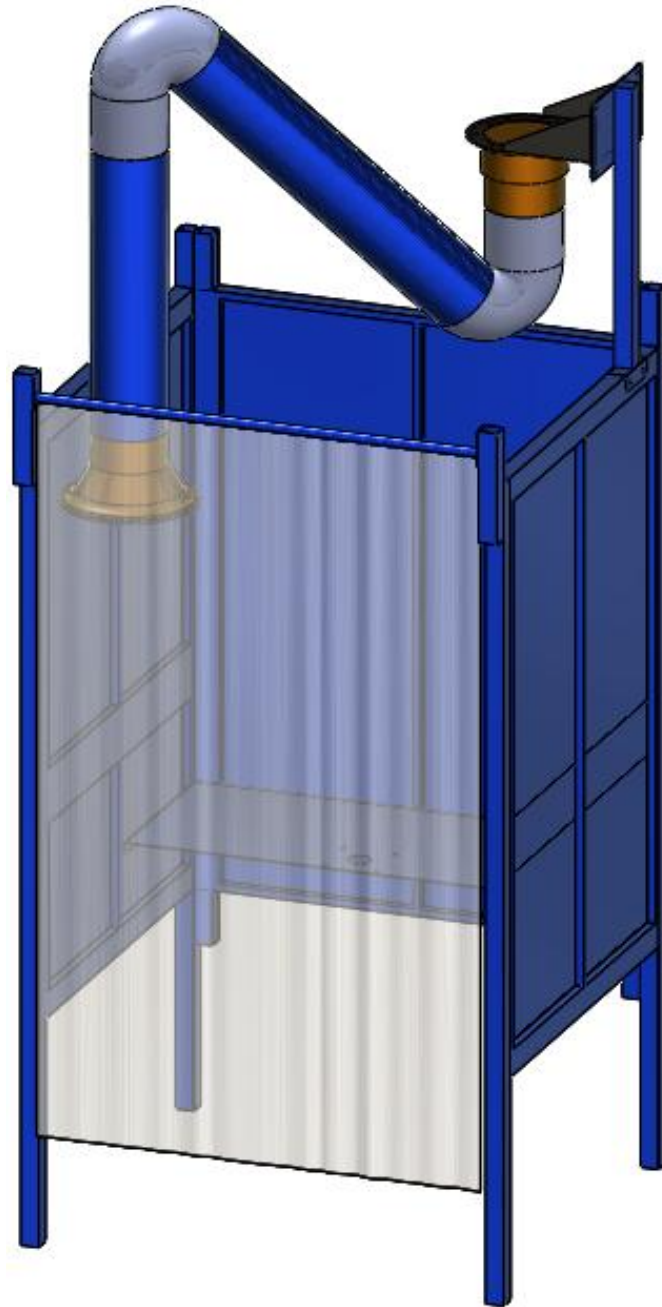

SDC-25x2-32MDF (21,200CFM @ 8"SP)

(2) 25HP top mounted fan on (1) large 32 cartridges collector (drawer type w/ feet, outside install)

SDC-25-24MDF (10,600CFM @ 8"SP)

(1) 25HP top mounted fan on (1) large 24 cartridges collector (drawer type w/ feet, outside install)

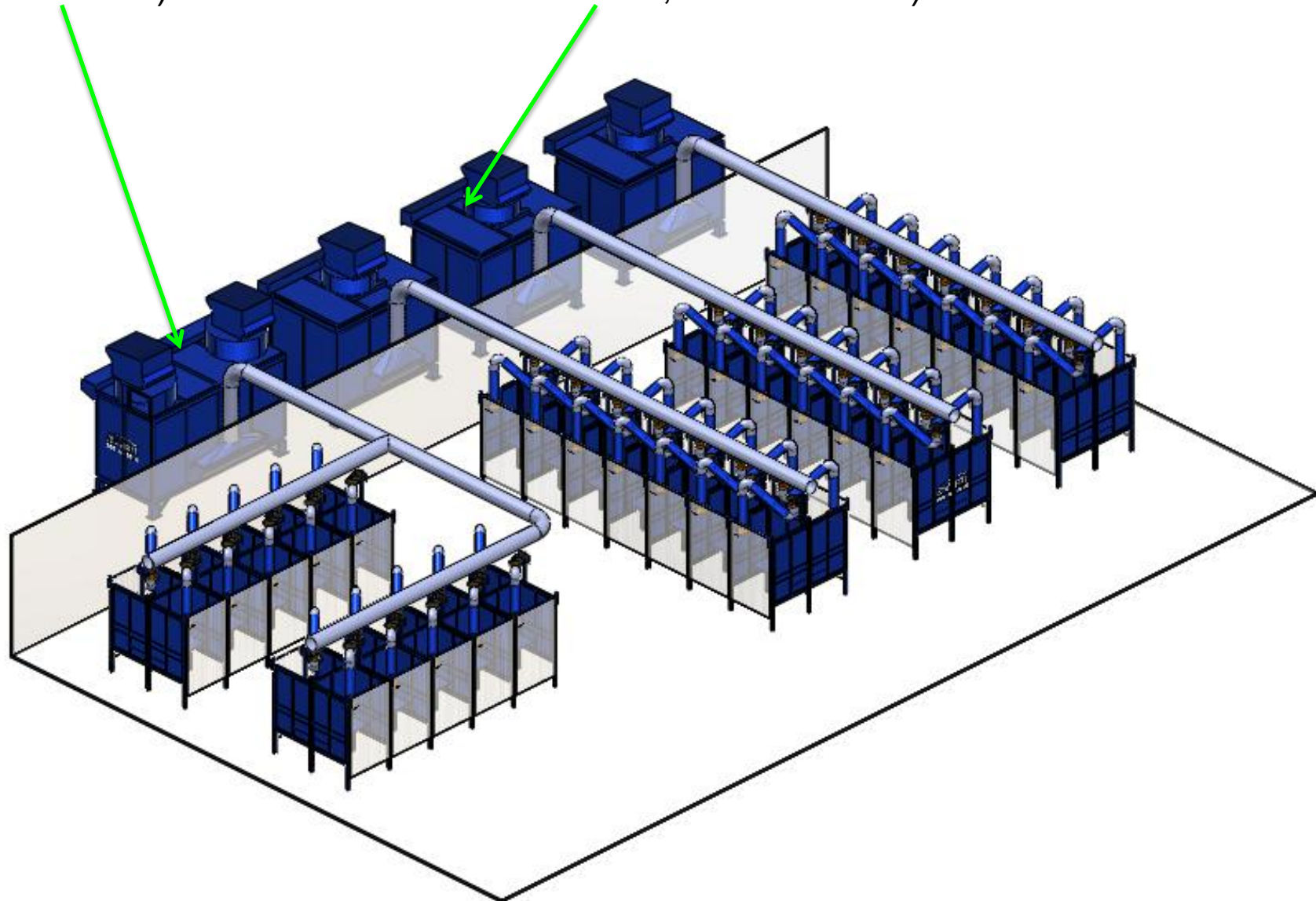

SDC-30-24MDF (13,000CFM @ 8"SP)

(1) 30HP top mounted fan on (1) large 24 cartridges collector (drawer type w/ feet, outside install)

