

NOTE(S):
 PRIOR TO APPROVAL, PLEASE NOTE ORIENTATION WITH RESPECT TO AISLE WAY. ALSO, SPECIFY ACCESS SIDE OF THE STAIR CASE TO THE MEZZANINE, AS WELL AS STAIR CASE STYLE, INLINE OR 90 DEGREE.

SPOTS MARKED 'A' REPRESENT APPROXIMATE POST PLACEMENT.

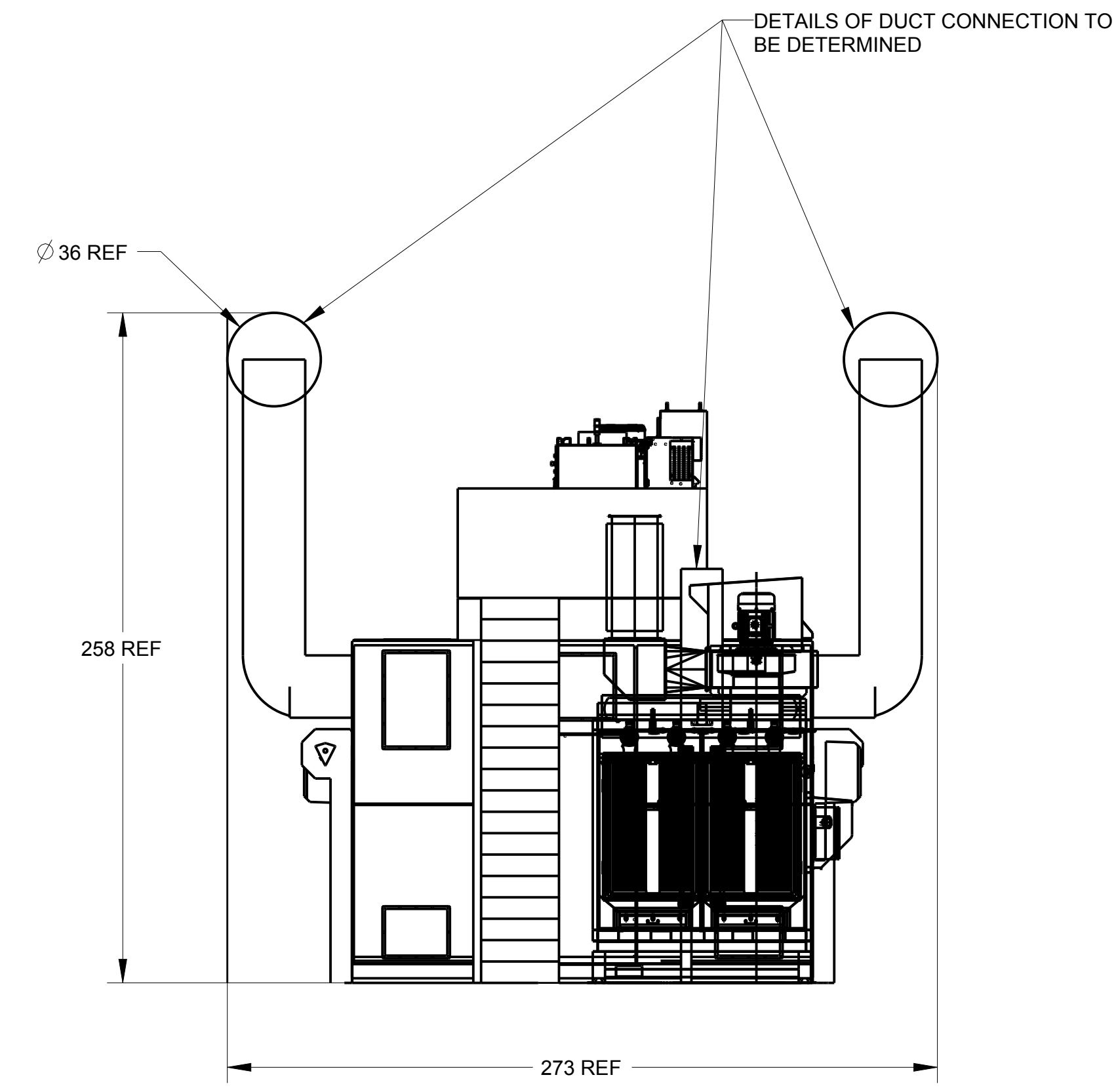

CUSTOMER APPROVAL	
APPROVED FOR BUILD	
<input type="checkbox"/>	AS DRAWN
<input type="checkbox"/>	WITH CHANGES AS NOTED
SIGNATURE:	
DATE:	



KEEP CROSS HATCHED AREAS CLEAR

FILE LOCATION: \prodstest\start_parts\210130B-0000

UNLESS OTHERWISE SPECIFIED		JR AUTOMATION TECHNOLOGIES, LLC		DRAWING FILE NAME		MACHINED BY	DATE COMPLETED	COMPLETION TIME	OK TO PRCG / DATE	DELIVER TO	REV. SEASON FOR REVISION	ENGINEER	REVISION DATE
DIMENSIONS ARE IN INCHES		ISO 9001 REGISTERED FIRM		210130-APPROVAL-LAYOUT							210130B-0000		0
3RD ANGLE PROJECTION		13385 TYLER STREET, HOLLAND, MI 49424		DESCRIPTION:									
DEBUR ALL SHARP EDGES		12688 NEW HOLLAND STREET, HOLLAND, MI 49424		2 CELL LAYOUT									
TAP DEPTH MIN 2X MAJOR DIA		13521 QUALITY DRIVE, HOLLAND, MI 49424		MANU / NUM									
ANGLE: 1° XXX4: 03 XXX6: 005		1473 WALHALLA HWY., PICKENS, SC 29671		PROCESS:									
XXXXX: 0002 DWES-0005		CUSTOMER / PROJECT DESCRIPTION		HEAT TREAT:									
DO NOT SCALE PRINT													

PRELIM
1 of 1