

Extraction Arm NEX MD



Nederman NEX MD is an extraction arm for medium to heavy duty applications. The arm has a Ø160 mm (6¼ inch) hose, which together with the external arm system provides a high air flow and a low pressure drop. Perfectly balanced and simple to position.



- Robust swivel - allows 360° rotation
- Encapsulated support mechanism protects the arm against dust and dirt
- Can be mounted on brackets, extension arms and exhaust rails
- With a damper in the hood - saves energy when not in operation
- The hose is easy to remove for cleaning
- The hood can be tilted in all directions

Pressure drop

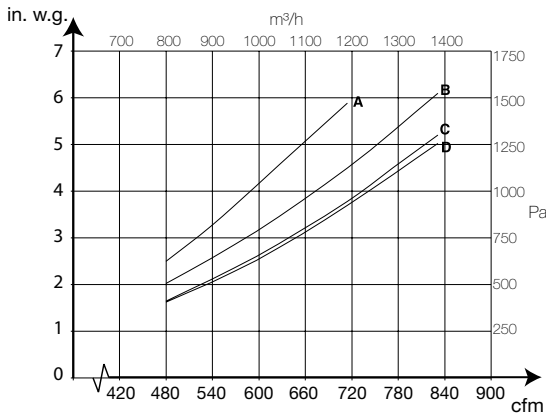

A: 5m (16 1/2ft.), B: 4m (14ft.), C: 3m (10ft.), D: 2m (7ft.)

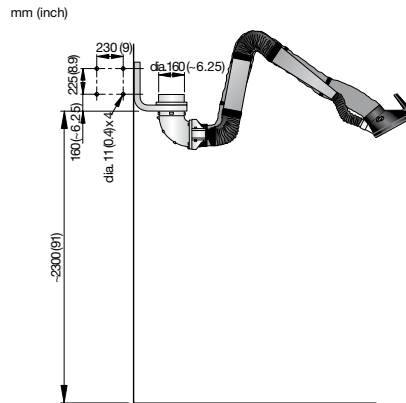

Description	Reach, m (ft.)	Airflow, m³/h (cfm)	Connection Ø, mm (in.)	Max. fume temperature, °C (°F)	Noise level at hood, dB(A)	Weight, kg (lb.)	Part no.
NEX MD 2 m (7 ft.)	2 (7)	900-1300 (500-800)	160 (6 1/4)	70 (160)	66	16 (35)	10561032
NEX MD 3 m (10 ft.)	3 (10)	900-1300 (500-800)	160 (6 1/4)	70 (160)	63	20 (44)	10561132
NEX MD 4 m (14 ft.)	4 (14)	900-1300 (500-800)	160 (6 1/4)	70 (160)	63	27 (60)	10561232
NEX MD 5 m (16 1/2 ft.)	5 (16 1/2)	900-1300 (500-800)	160 (6 1/4)	70 (160)	63	32 (70)	10561332