

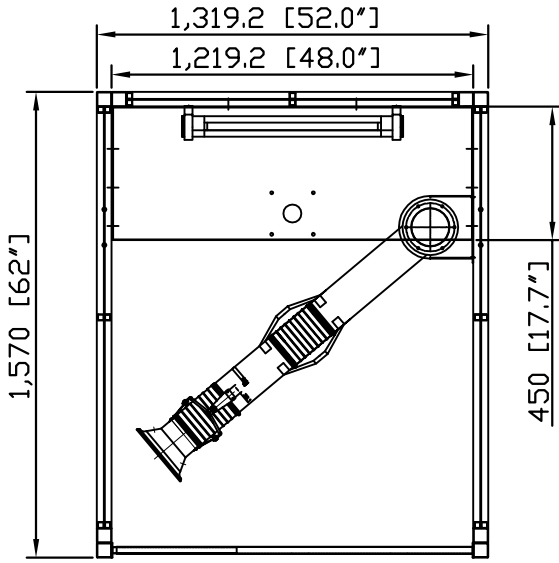

Revisions			
Rev	Description	Date	Approved

Arm 1220: dia. 5" x 7' hanging arm



WB-1054 WELDING BOOTH SPECIFICATIONS

- Adjustable Level System: (4) dia. 2.36" Feet
- Panel Construction: 11-gauge welded steel
- Welding Curtain Supports: (1) set welding curtain bar
- Fume Arm Base Supports: (1) to match an optional bracket (6 bolt pattern) and an optional dia. 6" fume arm
- Powder Coated: Avani Safety Blue Standard (custom colors available)
- Three Piece Configuration: (2) side panels, (1) back panel.
- Booths can be mounted back-to-back, side-by-side or both options
- ***Unadjustable Fixed Rear Shelf: 48"W x 20"D x 1.1"H (solid with 2" hole drilled)

OPTIONS

- Welded Nuts: Optional locations for J-Hooks
- Welding Nuts: For wire feeder or welder bracket

OPTIONAL ACCESSORIES:

- Arm 1620: dia. 6" x 7' hanging arm
- BR 006 bracket 006: mounting bracket for dia. 6" fume arm

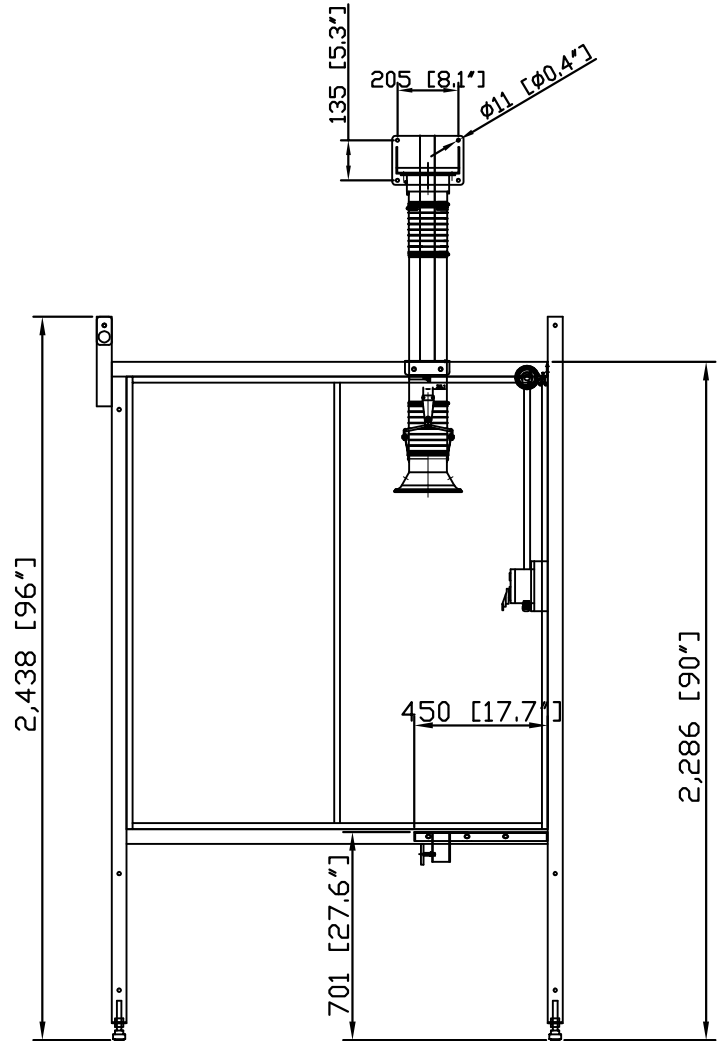
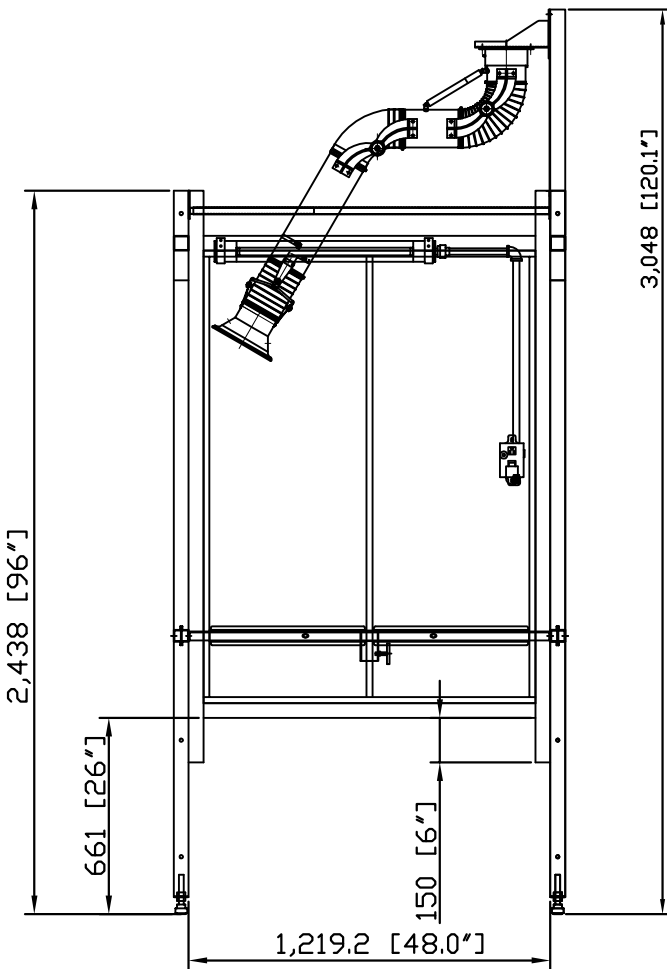

AVANI ENVIRONMENTAL INTL. INC. Sales Department
 95 Cypress Drive (919) 570-2862
 Youngsville, NC 27596 info@avanienvironmental.com

	Date	Name	Part Number:	Title:
Drawn by:	2012-07-30	***	***	Booth WB-1054
Checked by:				

The drawings, AutoCAD, 3-D Models, and specifications are the property of Avani Environmental Intl. Inc. (AE) and may not be reproduced, distributed, modified, or otherwise used, except provided herein, without the express written permission of AE.

Size	Scale	Drawing Number:
A	1 = 25	WB-5x5S