

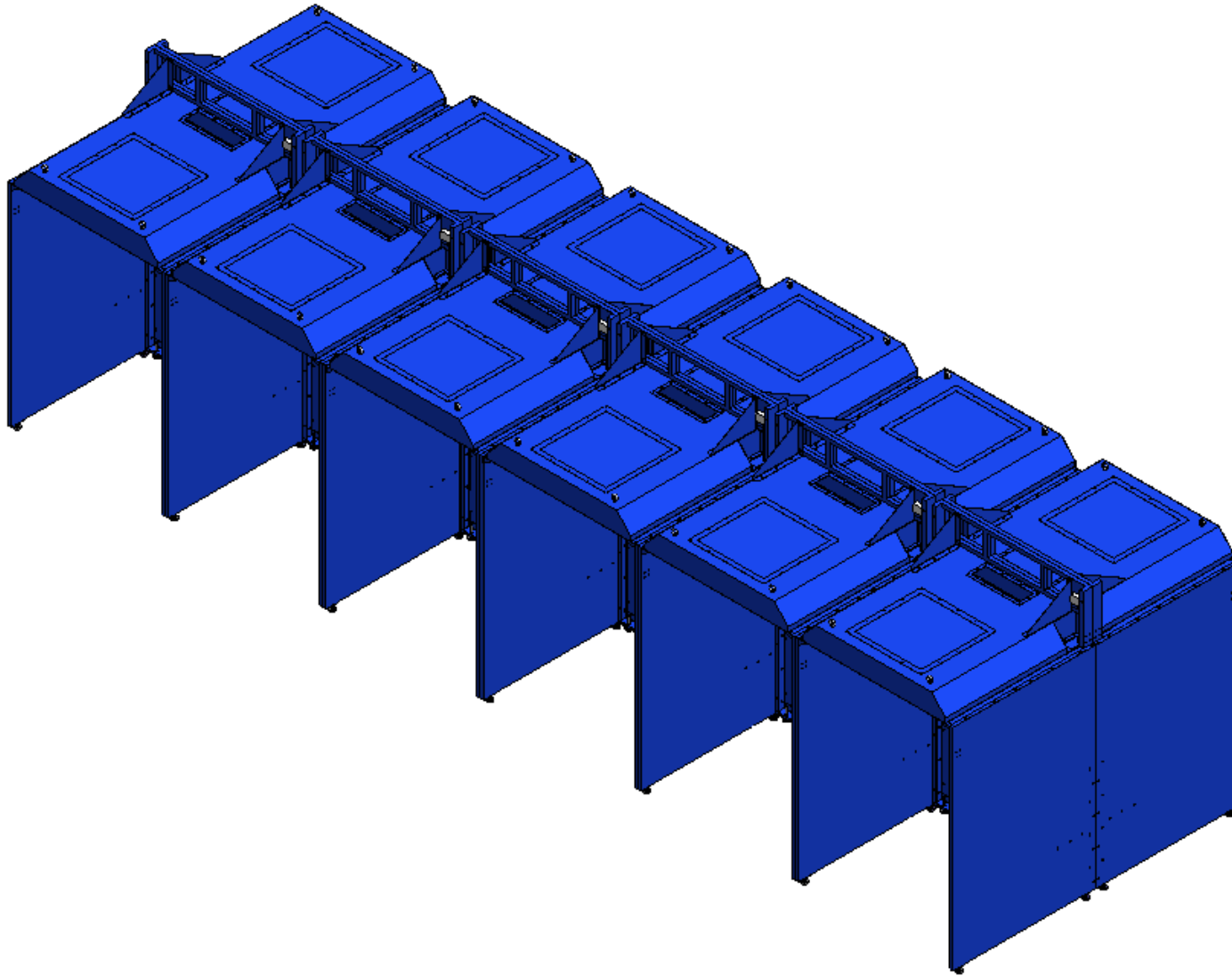

✚ Installations for WB-5055 (12 booths back to back).



✚ Installations for WB-5055 (12 booths back to back).

- Take out **Upper Part of the Backdraft** and **Lower Part of the Backdraft**.
- Join **Upper Part of the Backdraft** and **Lower Part of the Backdraft** together with:

Hardware R				
Part name	Description	Photos	Q'ty	Grainger Model #
Hex Screw	5/16 x 3/4"		144	1YU33
Flat Washer	5/16" x OD23 x 2T		192	*1JY31

(*) Hardware item at similar spec available locally.

✦ Installations for WB-5055 (12 booths back to back).

Upper Part of the Backdraft

Upper Part of the Backdraft

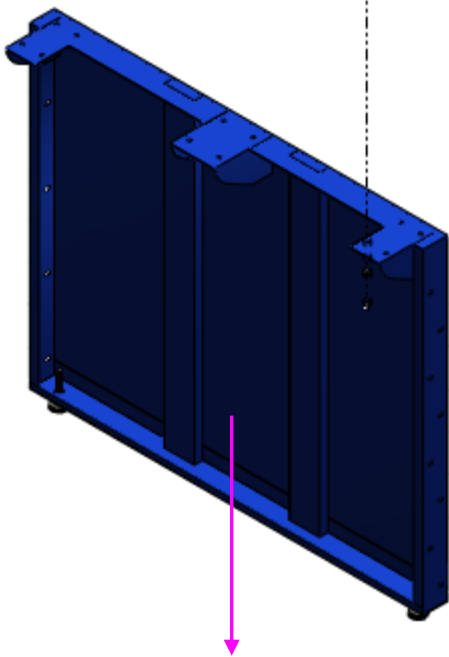
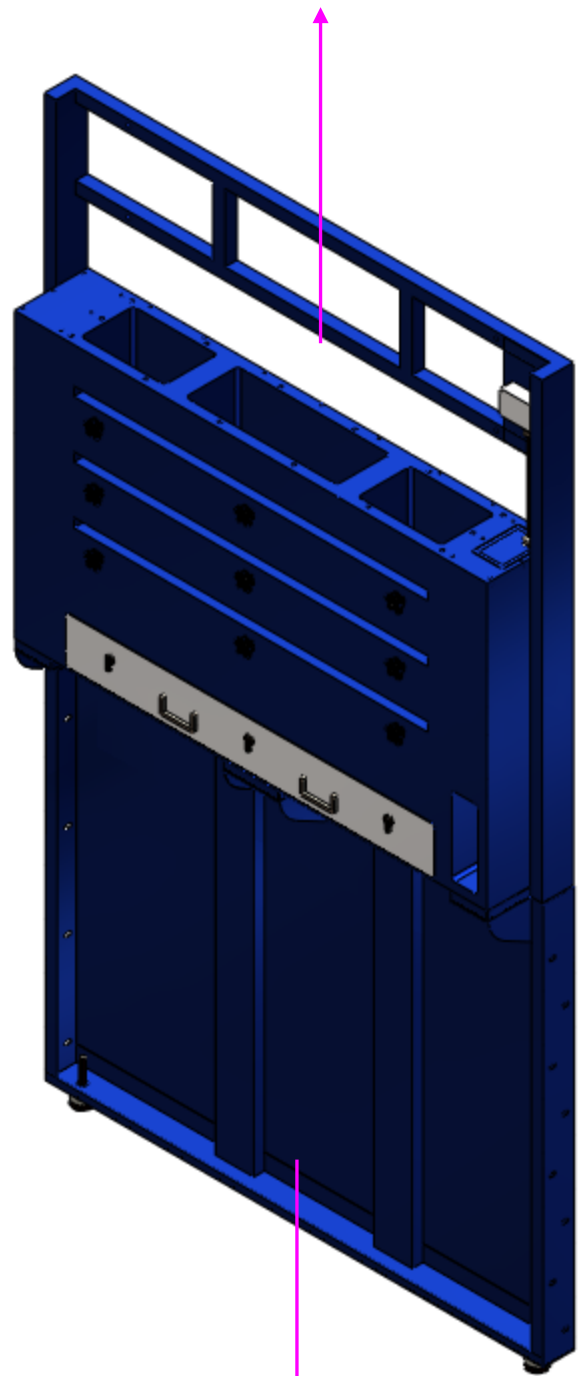
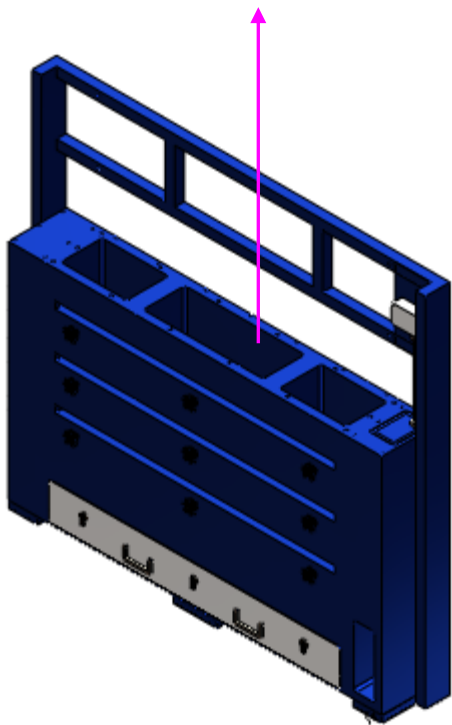



Lower Part of the Backdraft

Lower Part of the Backdraft

✚ Installations for WB-5055 (12 booths back to back).

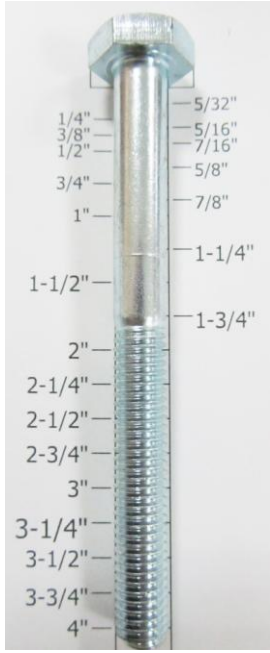
- Take out **Left Side Panel**.
- Fasten **Left Side Panel** to **Upper Part of the Backdraft** and **Lower Part of the Backdraft** together with:

Hardware C				
Part name	Description	Photos	Q'ty	Grainger Model #
Hex Screw (Partially Threaded)	3/8 x 4"		8	1KA62
Flat Washer	3/8" x OD23 x 2T		16	*1JY33
Nylon Hex Nut	3/8"		8	3HDU4

(* Hardware item at similar spec available locally.

✦ Installations for WB-5055 (12 booths back to back).

Upper Part of the Backdraft

Upper Part of the Backdraft

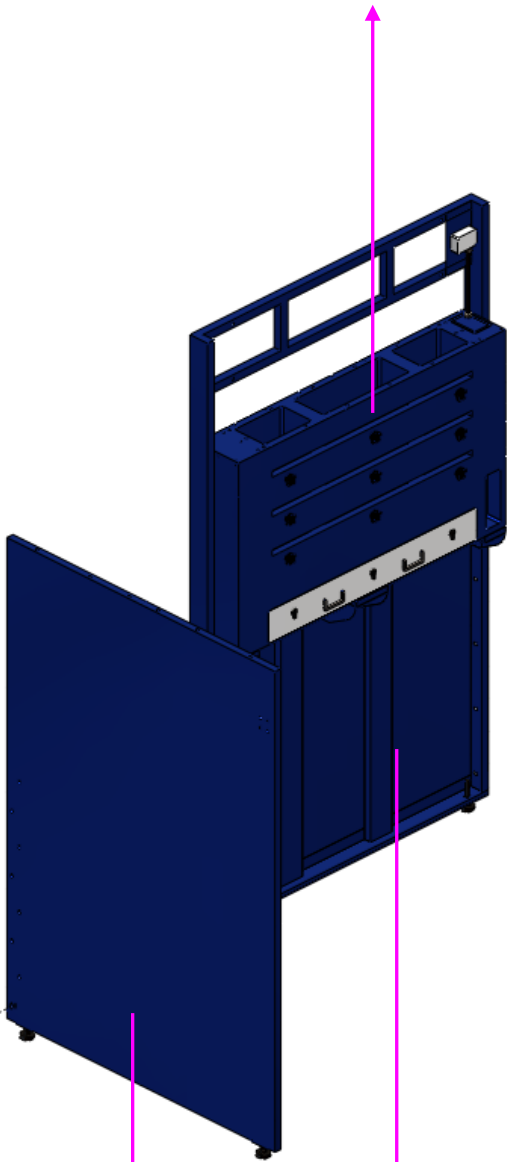

Left Side Panel

Lower Part of the Backdraft

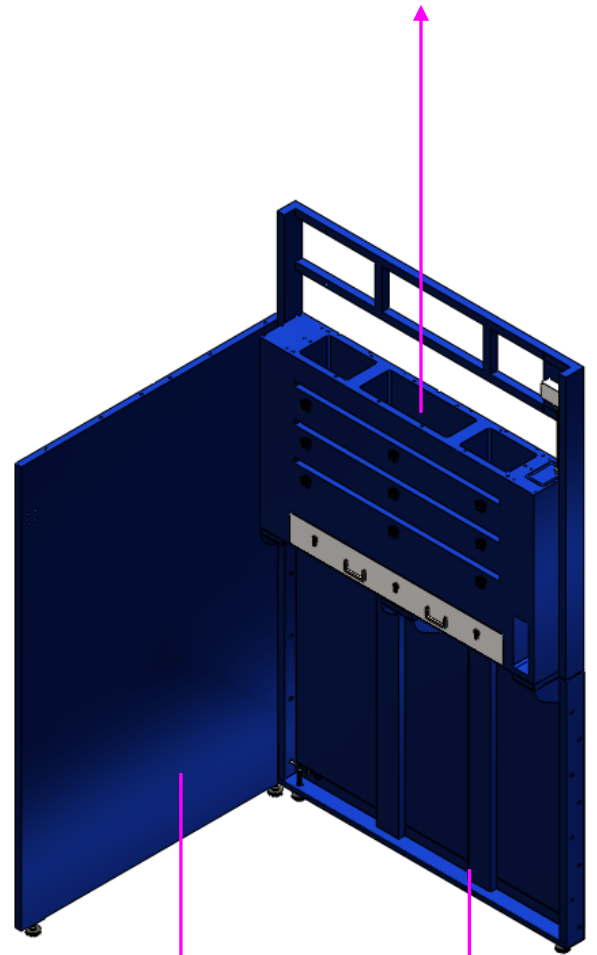



Left Side Panel

Lower Part of the Backdraft

✦ Installations for WB-5055 (12 booths back to back).

- Take out **Middle Panel**.
- Fasten **Middle Panel** to **Upper Part of the Backdraft** and **Low Part of the Backdraft** with :

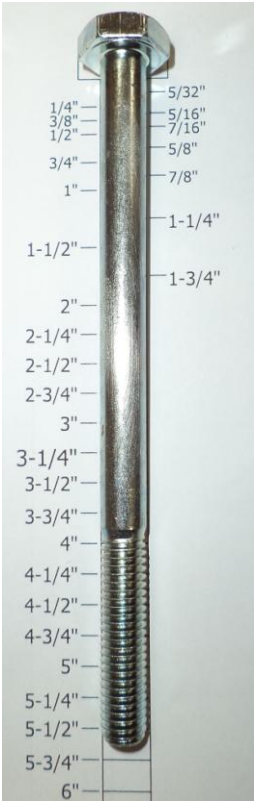
Hardware E

Part name	Description	Photos	Q'ty	Grainger Model #
Half-thread Screw	3/8 x 5-1/2"		50	1KA68
Flat Washer	3/8" x OD23 x 2T		100	*1JY33
Nylon Hex Nut	3/8"		50	3HDU4

(* Hardware item at similar spec available locally.

✦ Installations for WB-5055 (12 booths back to back).

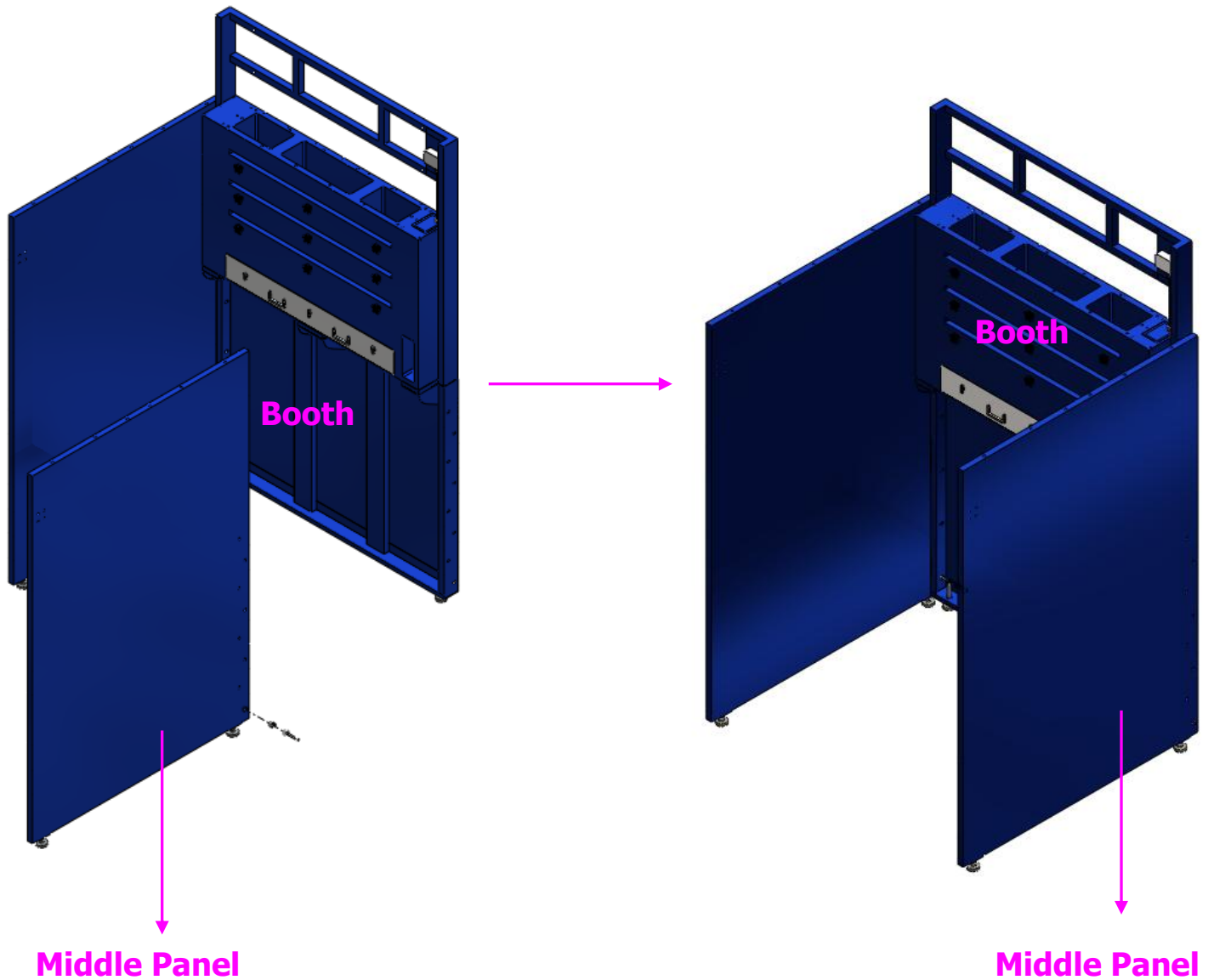

Ⓢ **Note: do not completely tighten the hardware at this time. After all Middle Panels are in position, ensure all holes patterns match. Then, proceed fastening.**

✚ Installations for WB-5055 (12 booths back to back).

- Take out **Booth**.
- Join **Booth** and **Booth** together with :

Hardware T				
Part name	Description	Photos	Q'ty	Grainger Model #
Half-thread Screw	3/8 x 9"		72	4RUH1

✚ Installations for WB-5055 (12 booths back to back).

Flat Washer	3/8" x OD23 x 2T		144	*1JY33
Nylon Hex Nut	3/8"		72	3HDU4

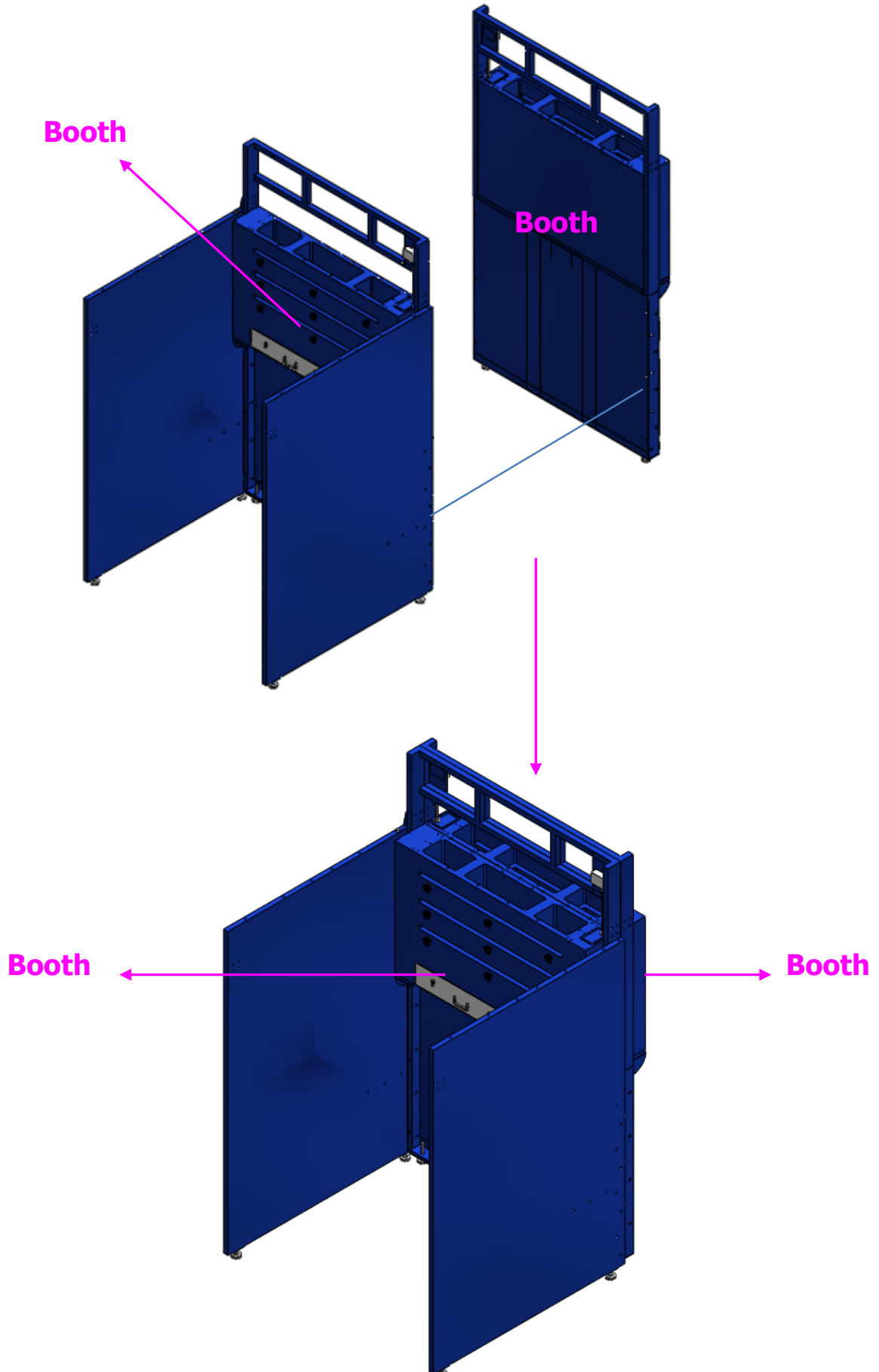

(*) Hardware item at similar spec available locally.

✦ Installations for WB-5055 (12 booths back to back).

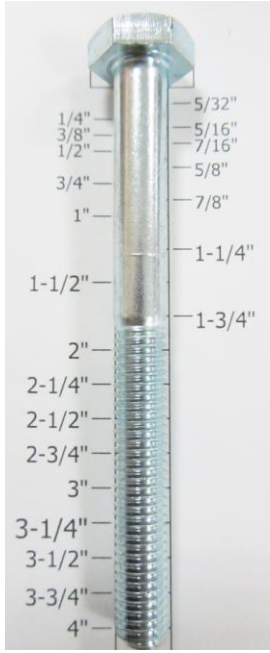

✚ Installations for WB-5055 (12 booths back to back).

- Take out **Left Side Panel**.
- Fasten **Left Side Panel** to **Upper Part of the Backdraft** and **Lower Part of the Backdraft** together with:

Hardware C				
Part name	Description	Photos	Q'ty	Grainger Model #
Hex Screw (Partially Threaded)	3/8 x 4"		8	1KA62
Flat Washer	3/8" x OD23 x 2T		16	*1JY33
Nylon Hex Nut	3/8"		8	3HDU4

(* Hardware item at similar spec available locally.

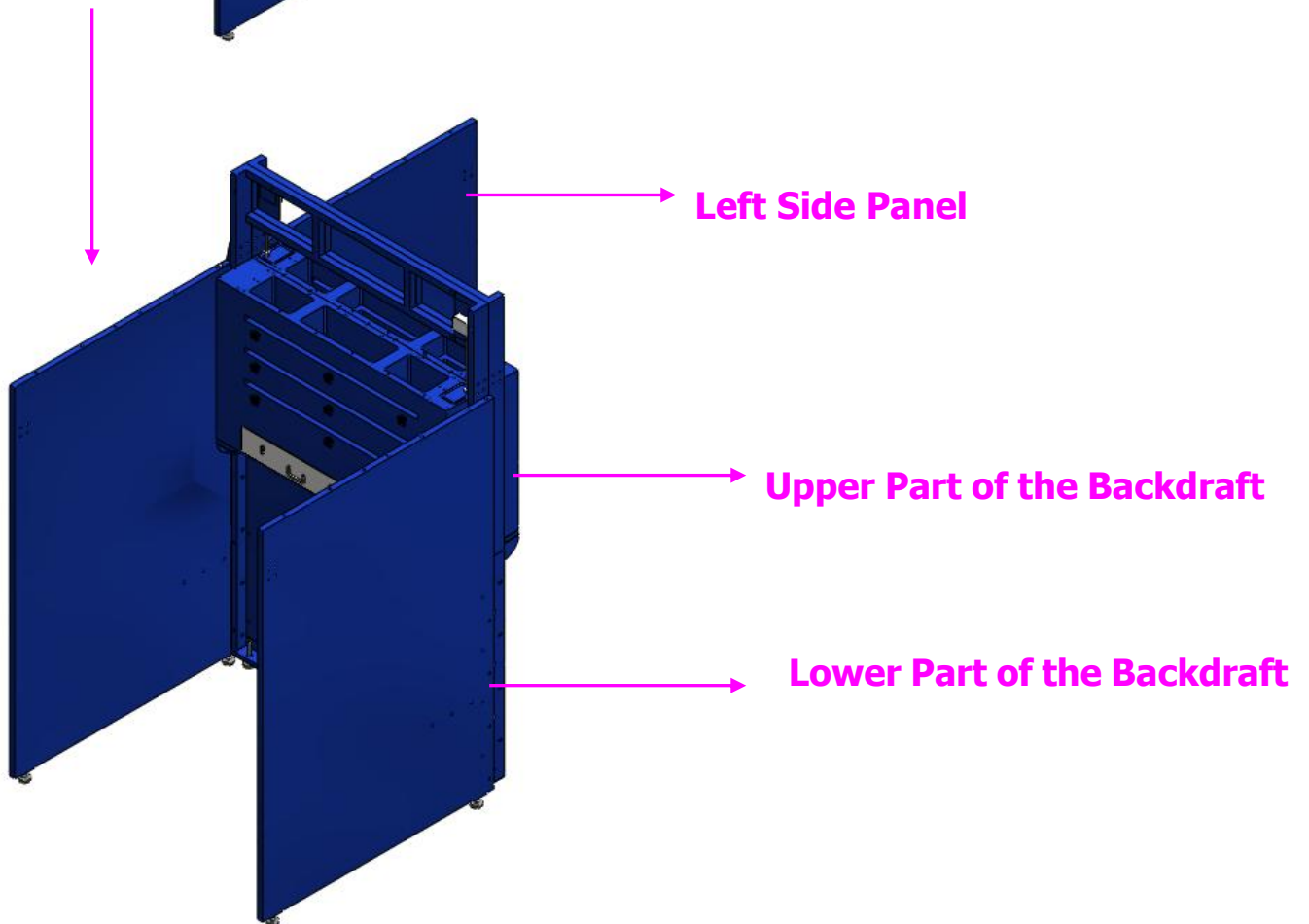
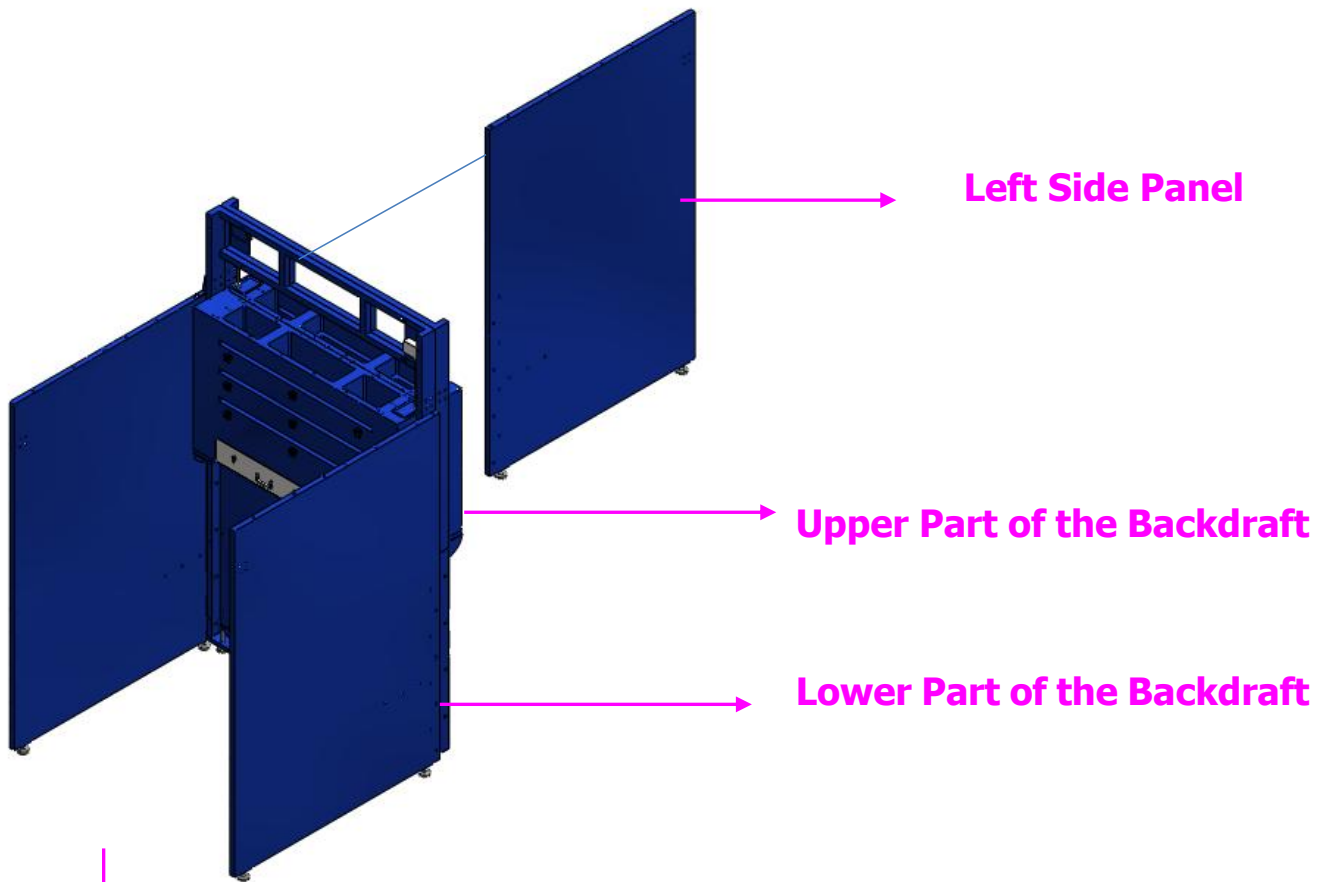

✦ Installations for WB-5055 (12 booths back to back).



✚ Installations for WB-5055 (12 booths back to back).

- Take out **Middle Panel**.
- Fasten **Middle Panel** to **Upper Part of the Backdraft** and **Low Part of the Backdraft** with :

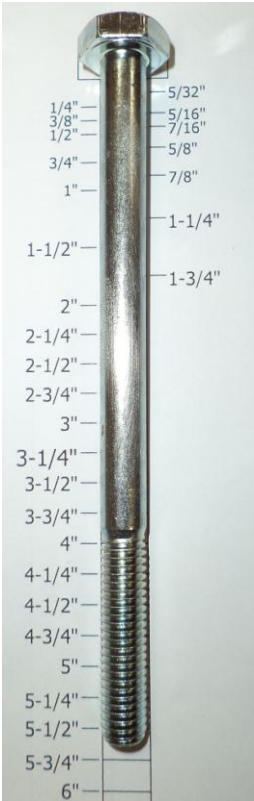
Hardware E

Part name	Description	Photos	Q'ty	Grainger Model #
Half-thread Screw	3/8 x 5-1/2"		50	1KA68
Flat Washer	3/8" x OD23 x 2T		100	*1JY33
Nylon Hex Nut	3/8"		50	3HDU4

(* Hardware item at similar spec available locally.

✦ Installations for WB-5055 (12 booths back to back).

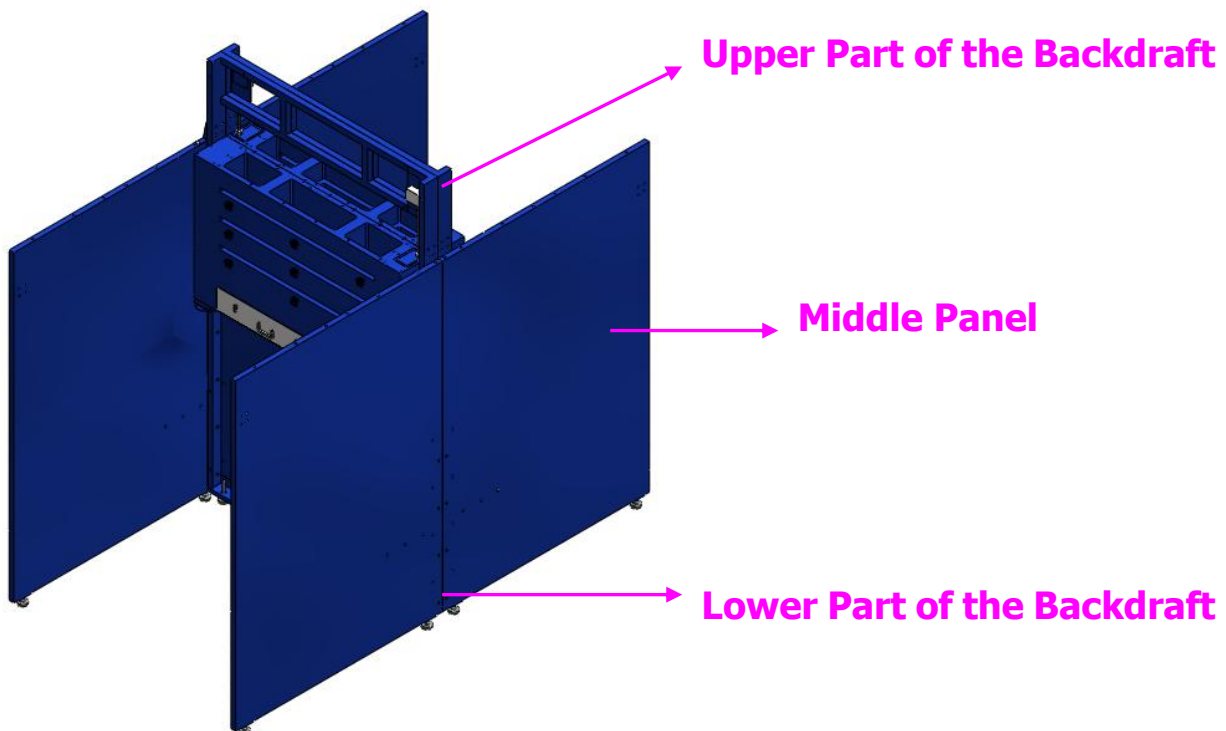
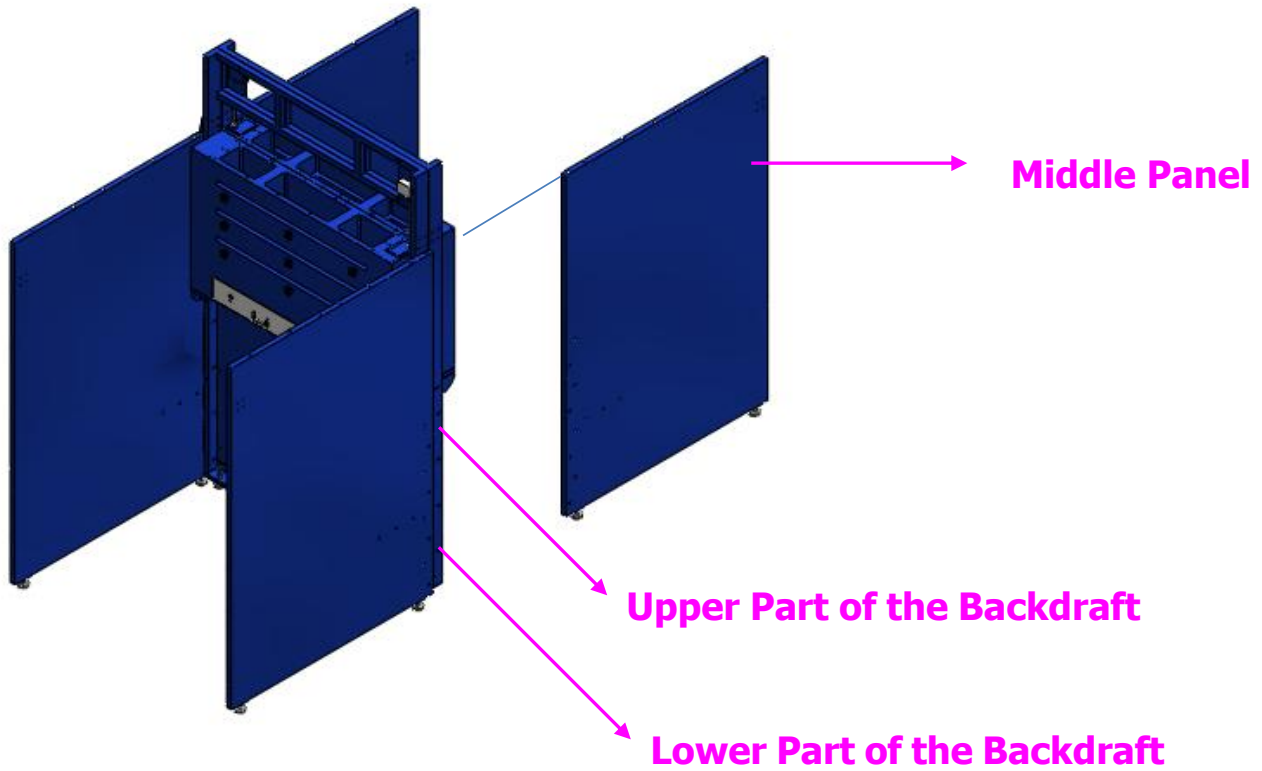

Ⓢ **Note: do not completely tighten the hardware at this time. After all Middle Panels are in position, ensure all holes patterns match. Then, proceed fastening.**

✚ Installations for WB-5055 (12 booths back to back).

- Take out **Booth**.
- Join **Middle Panel** and **Booths** together with :

Hardware E				
Part name	Description	Photos	Q'ty	Grainger Model #
Half-thread Screw	3/8 x 5-1/2"		50	1KA68
Flat Washer	3/8" x OD23 x 2T		100	*1JY33
Nylon Hex Nut	3/8"		50	3H DU4

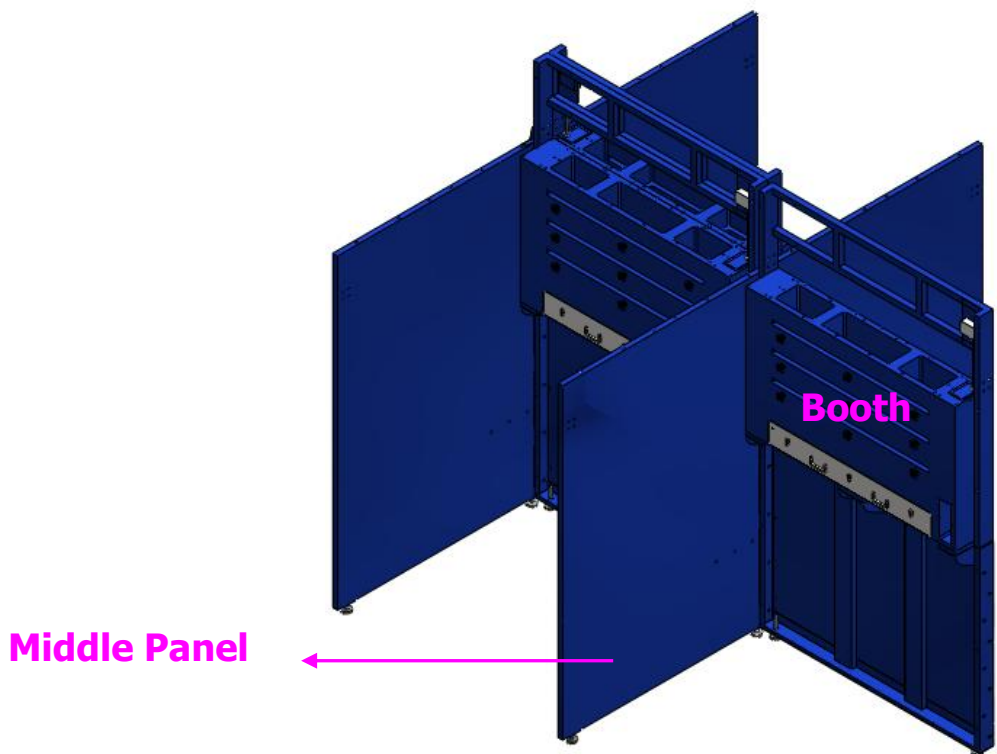
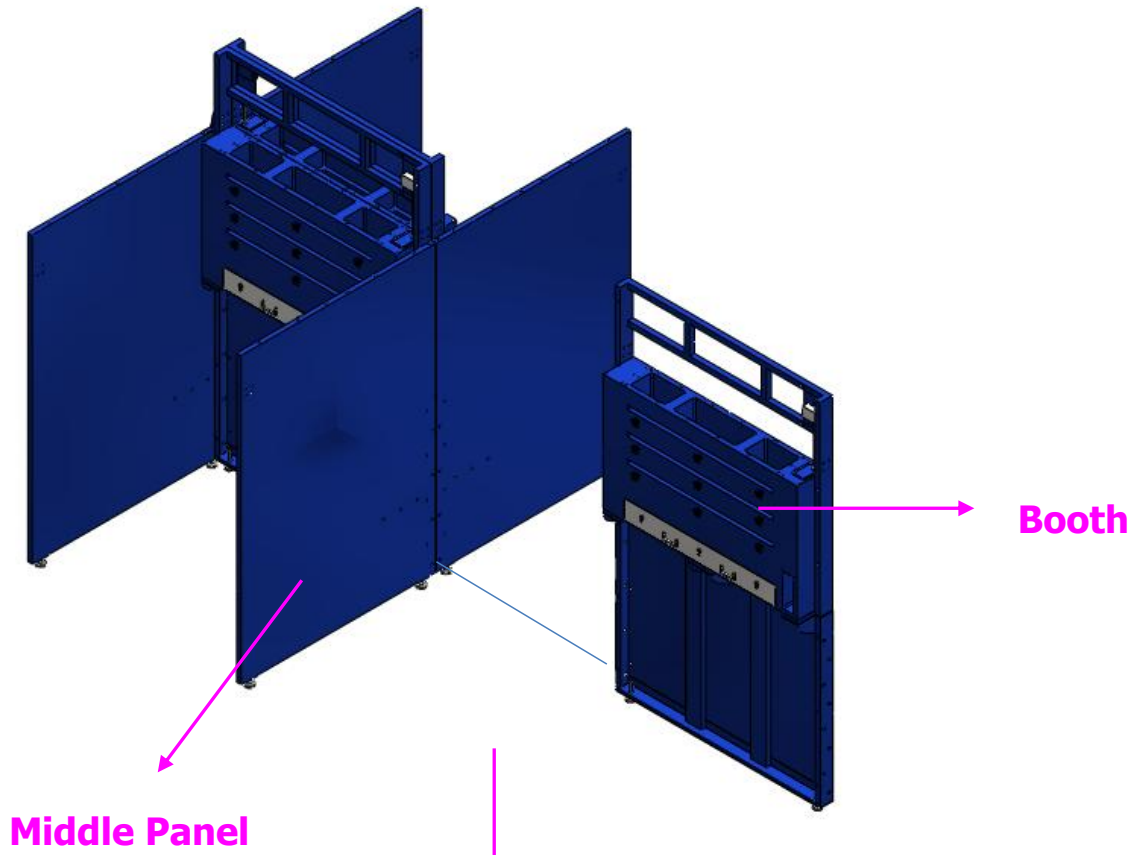

(* Hardware item at similar spec available locally.

✦ Installations for WB-5055 (12 booths back to back).

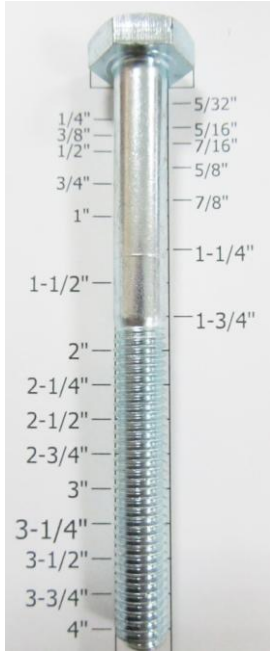

✚ Installations for WB-5055 (12 booths back to back).

- Take out **Right Side Panel**.
- Fasten **Right Side Panel** adjacent to **Booth** with:

Hardware D				
Part name	Description	Photos	Q'ty	Grainger Model #
Half-thread Screw	3/8 x 4"		8	1KA62
Flat Washer	3/8" x OD23 x 2T		16	*1JY33
Nylon Hex Nut	3/8"		8	3HDU4

(* Hardware item at similar spec available locally.

✦ Installations for WB-5055 (12 booths back to back).

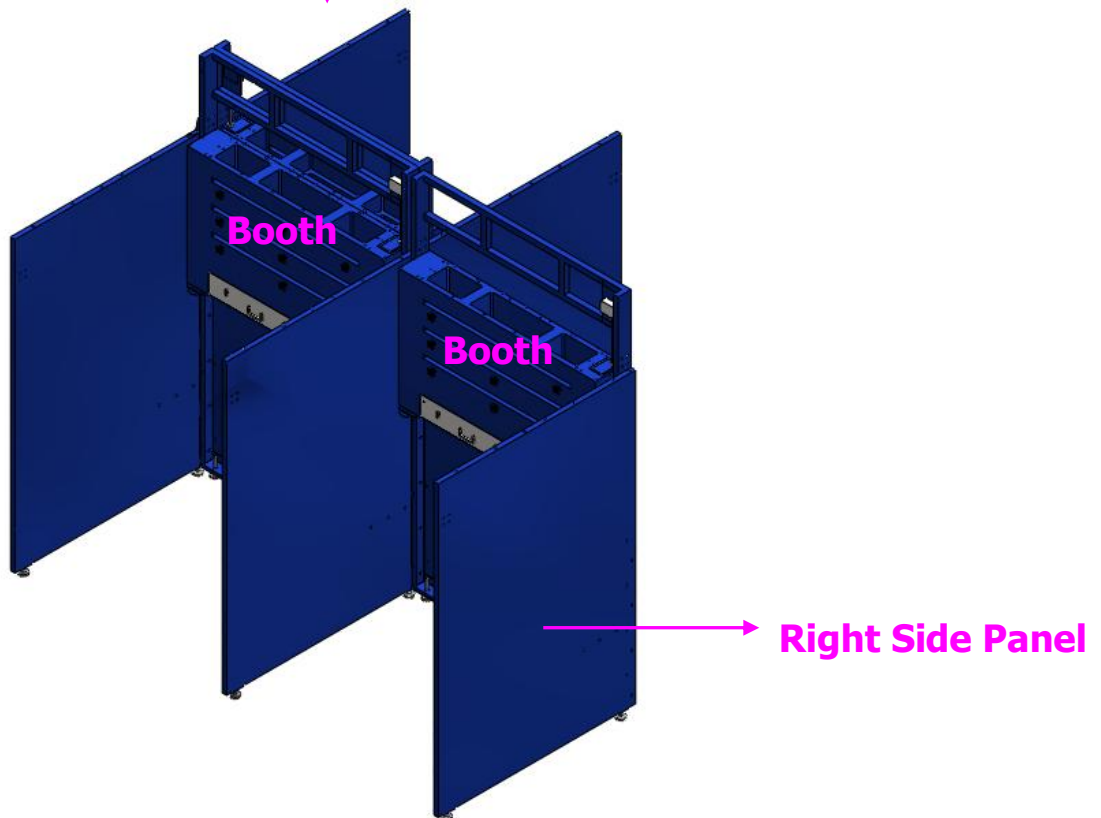
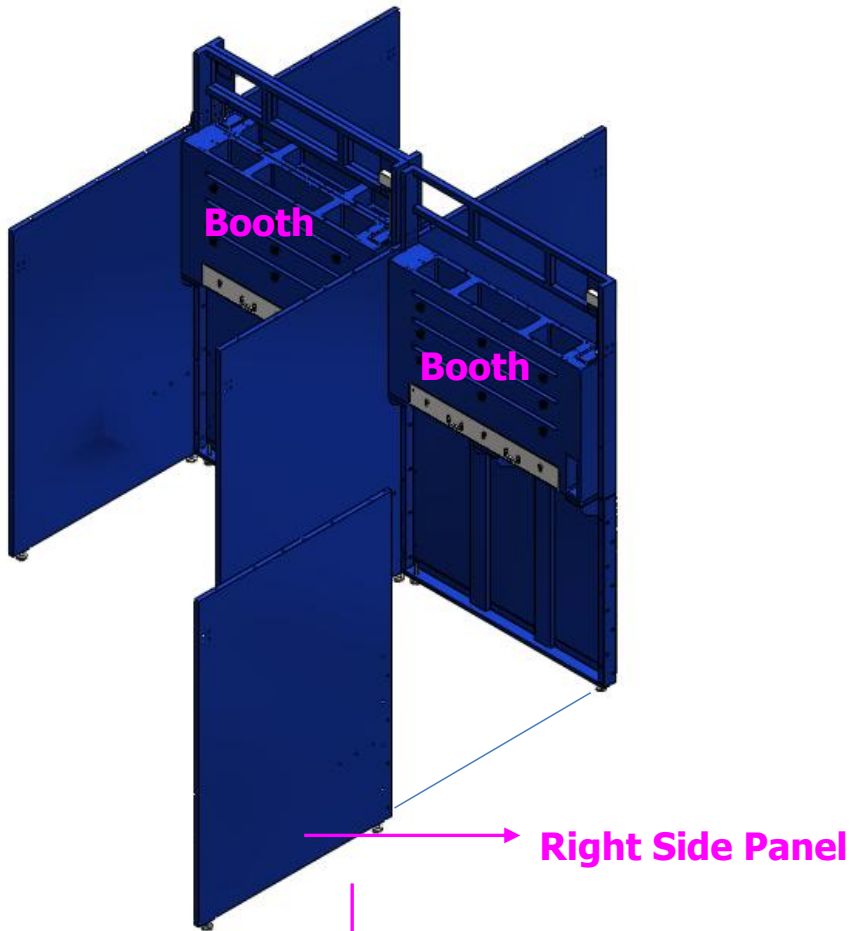

✚ Installations for WB-5055 (12 booths back to back).

- Take out **Booth**.
- Join **Booth** and **Booth** together with :

Hardware T				
Part name	Description	Photos	Q'ty	Grainger Model #
Half-thread Screw	3/8 x 9"		72	4RUH1

✚ Installations for WB-5055 (12 booths back to back).

Flat Washer	3/8" x OD23 x 2T	 <p>OD23 3/8"</p>	144	*1JY33
Nylon Hex Nut	3/8"	 <p>3/8" NYLON HEX NUT</p>	72	3HDU4

(* Hardware item at similar spec available locally.

✦ Installations for WB-5055 (12 booths back to back).

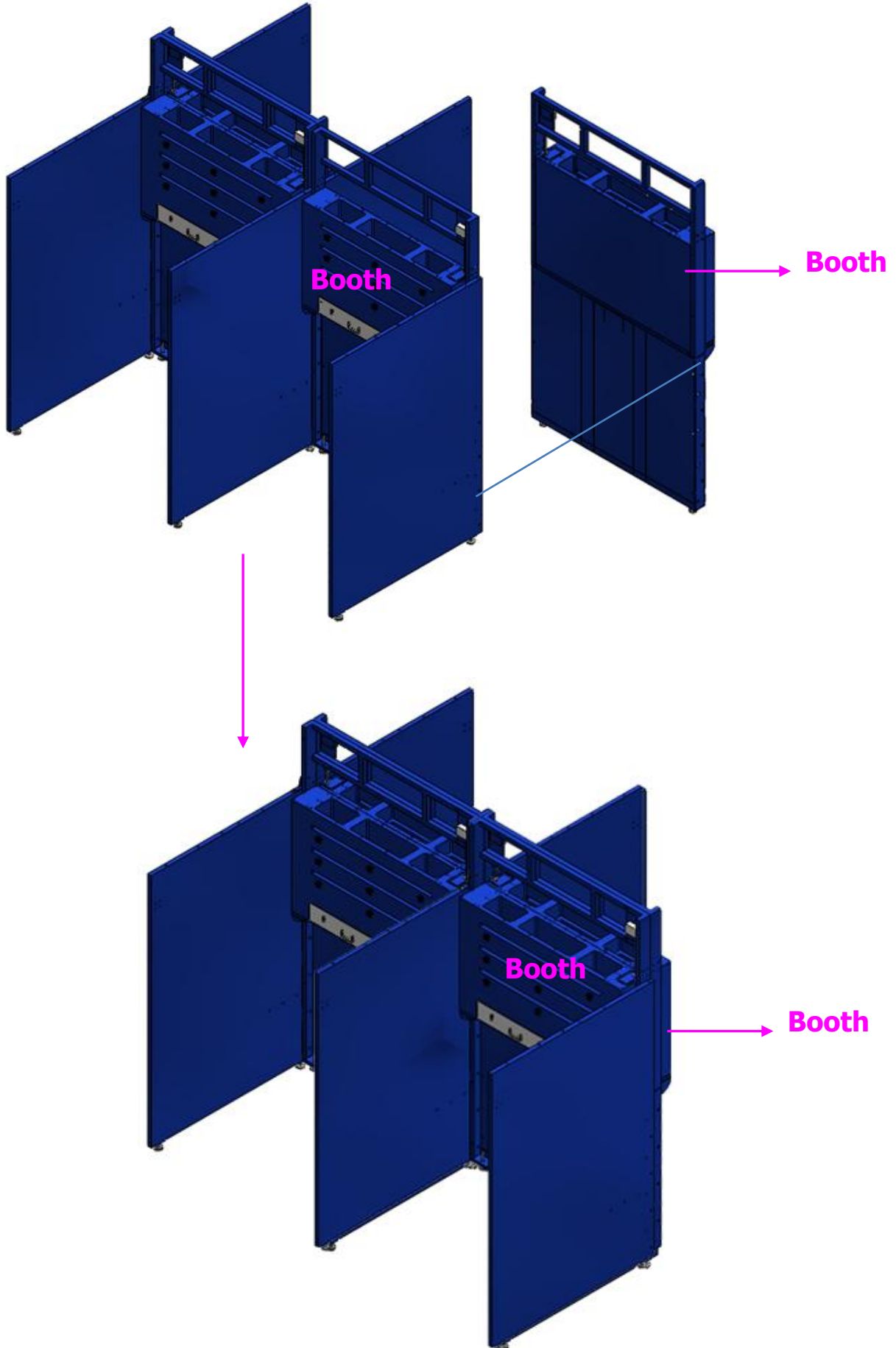

✚ Installations for WB-5055 (12 booths back to back).

- Join **Middle Panel** and **Booths** together with :

Hardware E				
Part name	Description	Photos	Q'ty	Grainger Model #
Half-thread Screw	3/8 x 5-1/2"		50	1KA68
Flat Washer	3/8" x OD23 x 2T		100	*1JY33
Nylon Hex Nut	3/8"		50	3HDU4

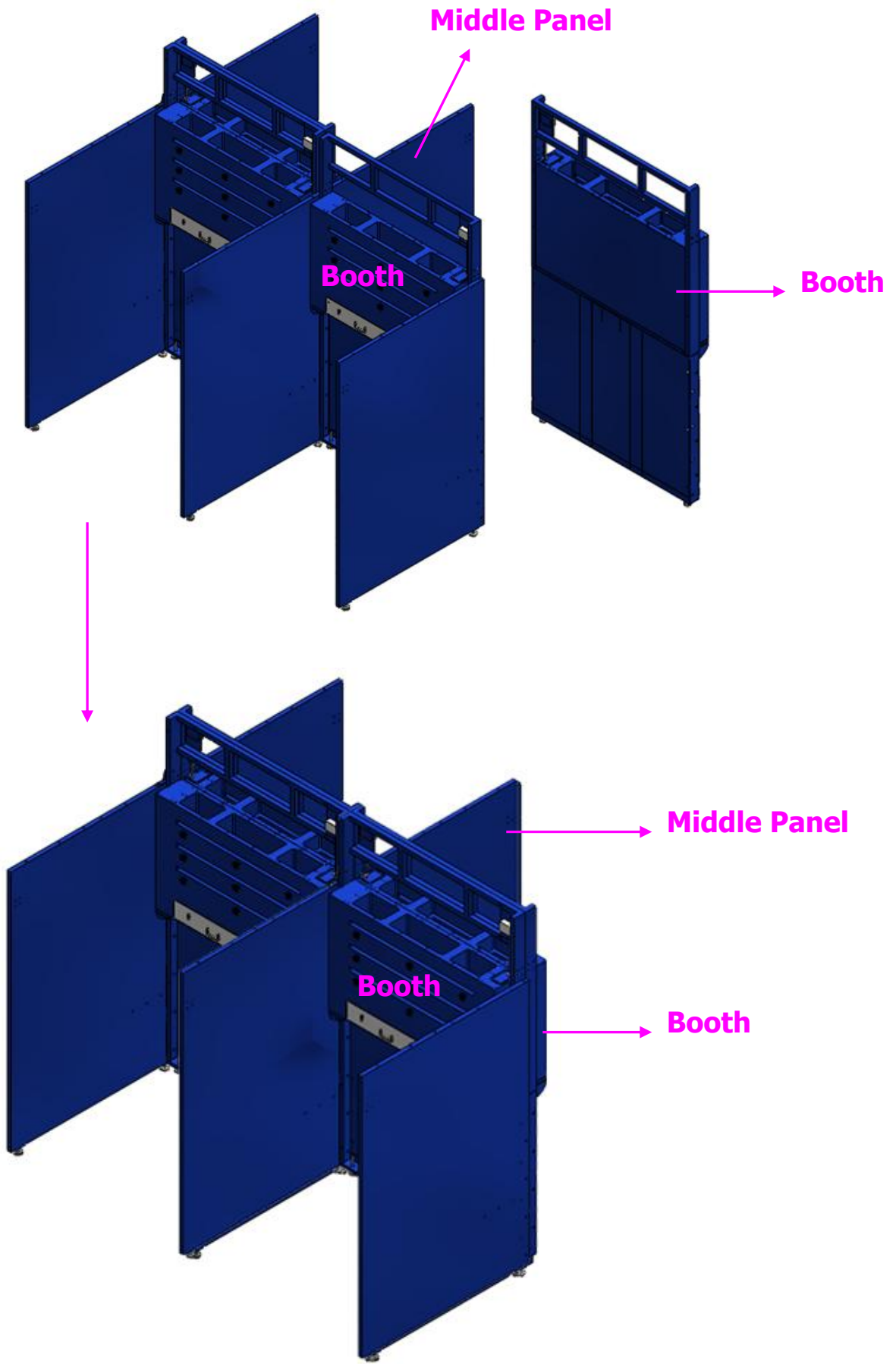

(* Hardware item at similar spec available locally.

✦ Installations for WB-5055 (12 booths back to back).

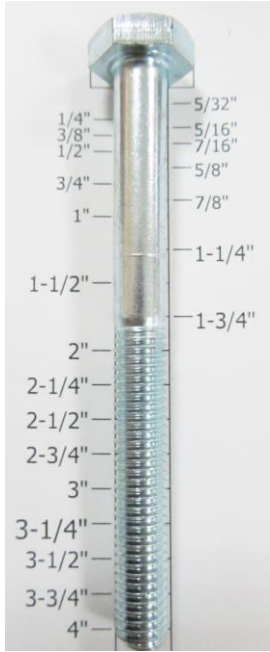

✚ Installations for WB-5055 (12 booths back to back).

- Take out **Right Side Panel**.
- Fasten **Right Side Panel** adjacent to **Booth** with:

Hardware D				
Part name	Description	Photos	Q'ty	Grainger Model #
Half-thread Screw	3/8 x 4"		8	1KA62
Flat Washer	3/8" x OD23 x 2T		16	*1JY33
Nylon Hex Nut	3/8"		8	3HDU4

(* Hardware item at similar spec available locally.

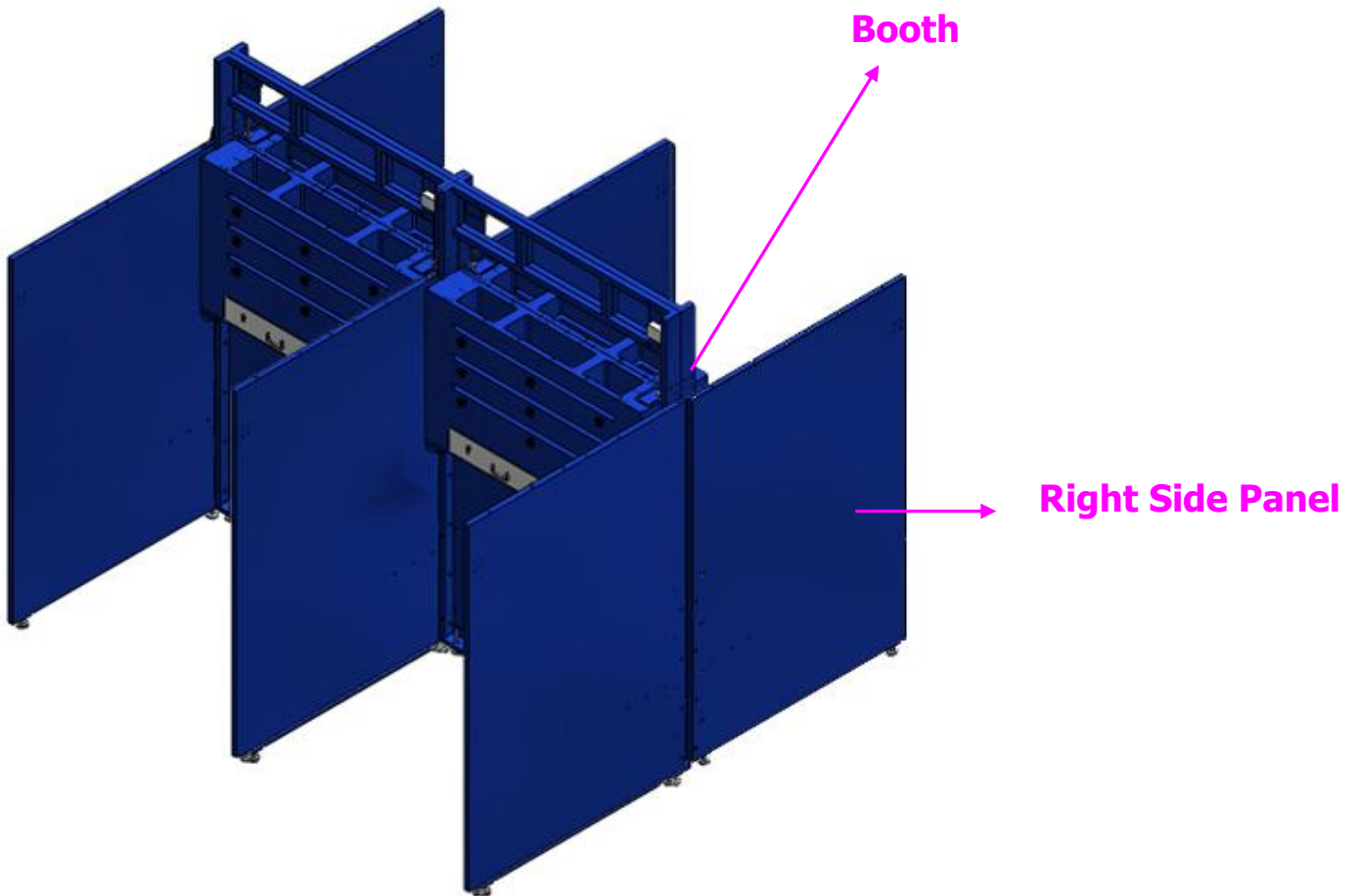
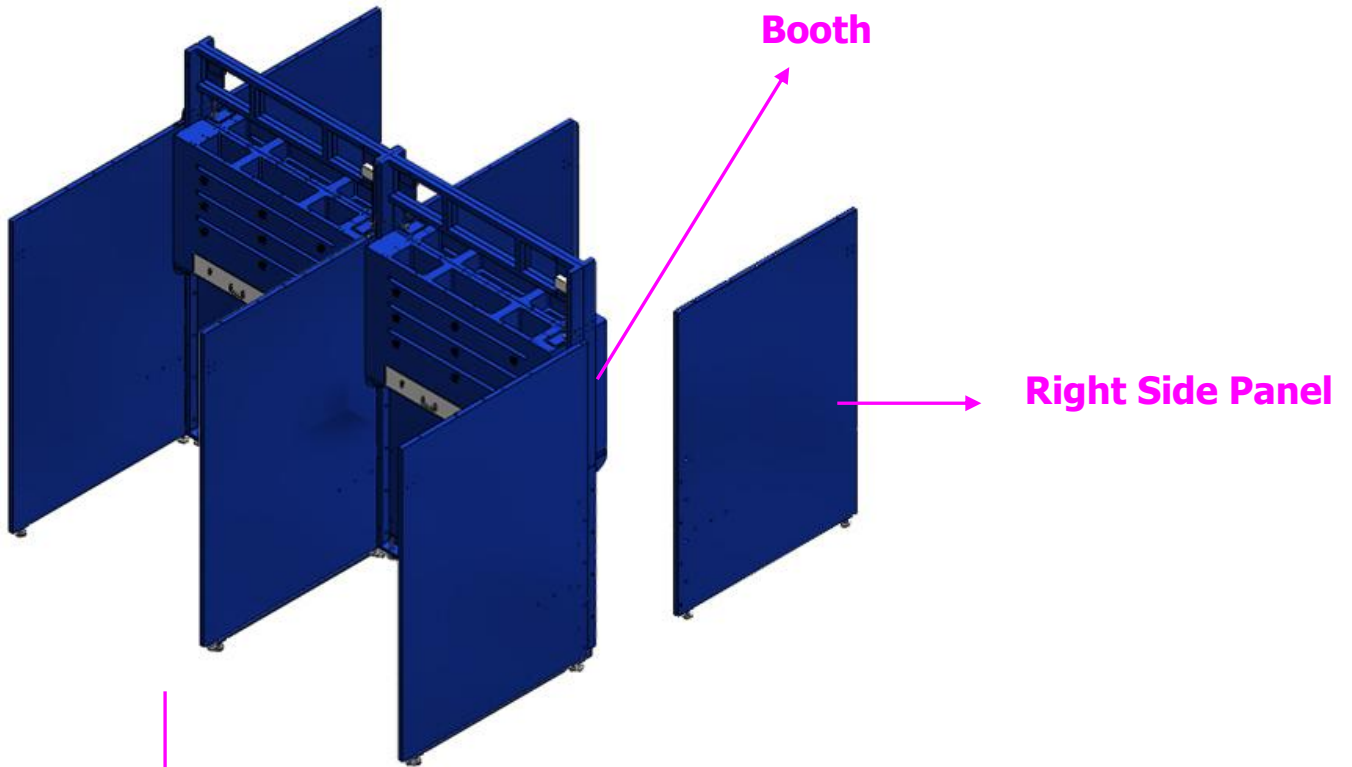

✦ Installations for WB-5055 (12 booths back to back).



✚ Installations for WB-5055 (12 booths back to back).

- Take out **Left Side Panel Top Joint**.
- Fasten **Left Side Panel Top Joint** adjacent to **Left Side**

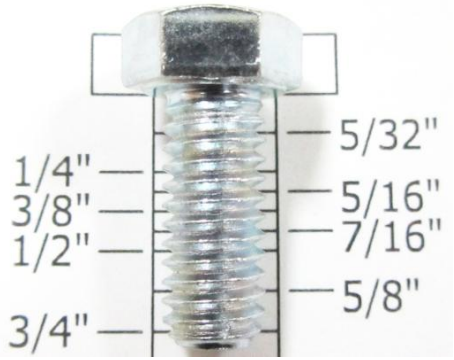
Panel with:

Hardware J				
Part name	Description	Photos	Q'ty	Grainger Model #
Hex Screw	5/16 x 3/4"		12	1YU33
Flat Washer	5/16" x OD23 x 2T		12	*1JY31

(* Hardware item at similar spec available locally.

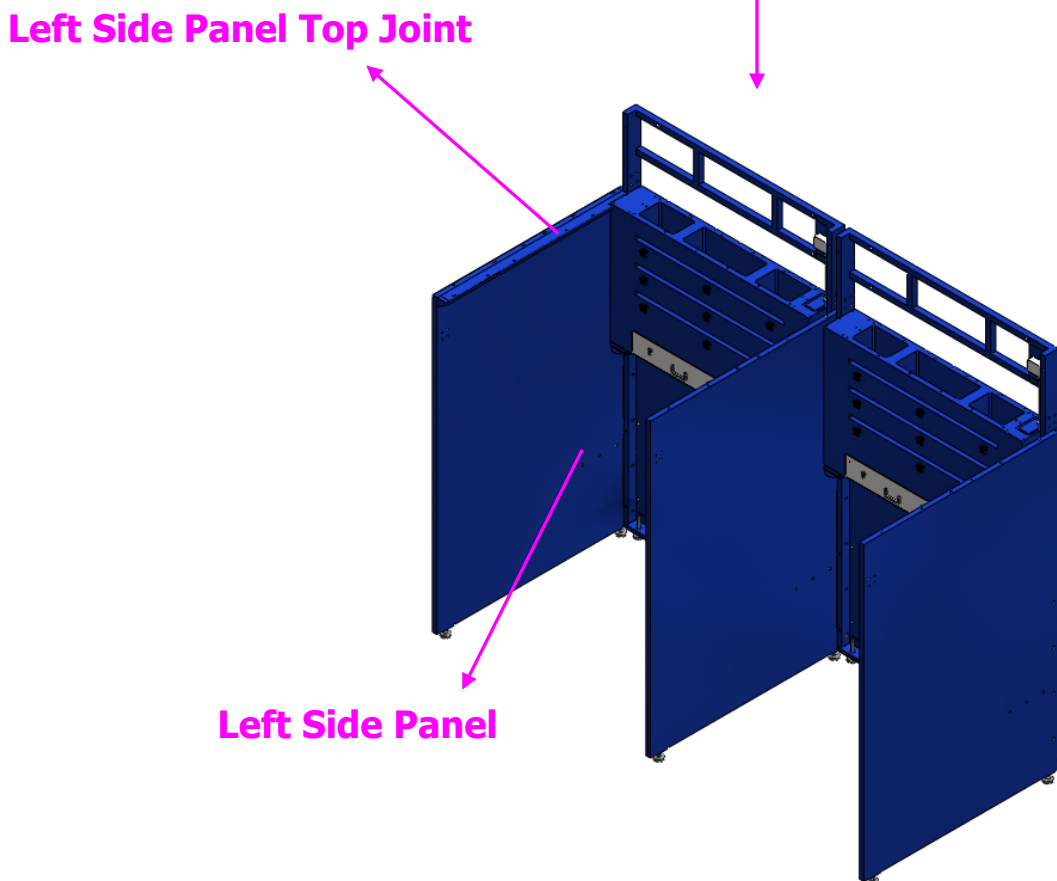
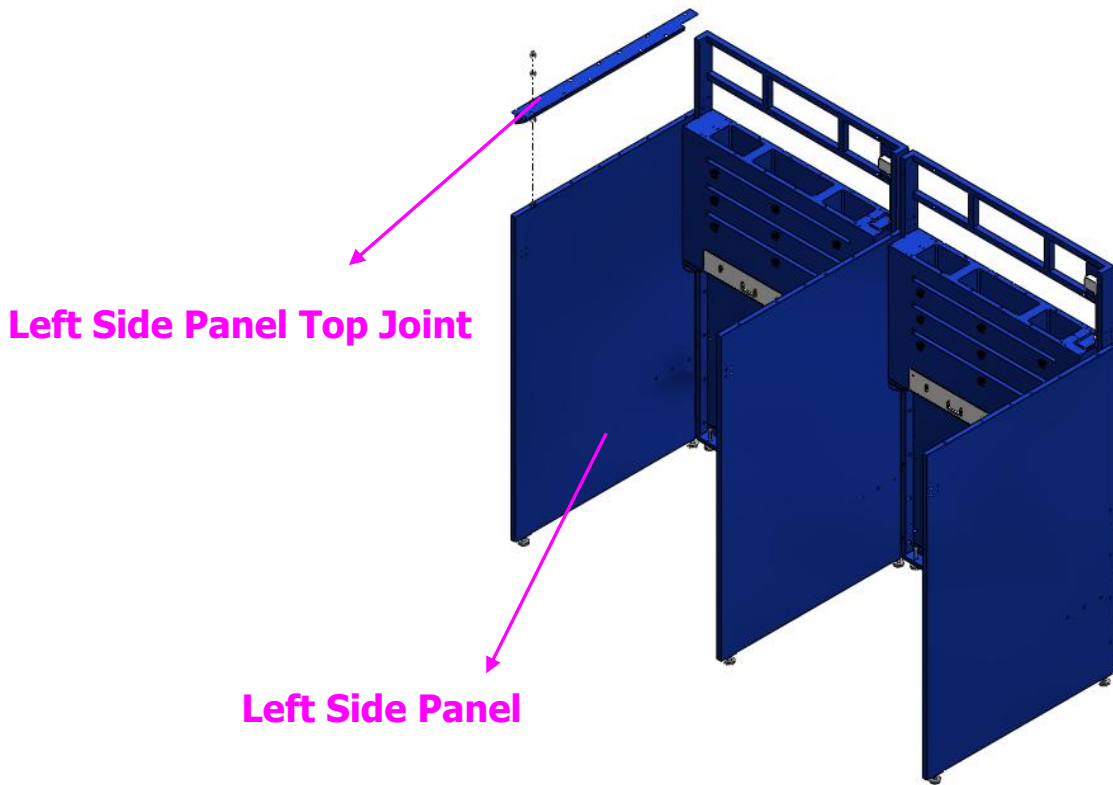

Installations for WB-5055 (12 booths back to back).



✦ Installations for WB-5055 (12 booths back to back).

- Take out **Middle Panel Top Joint**.
- Fasten **Middle Panel Top Joint** adjacent to **Middle Panel** with:

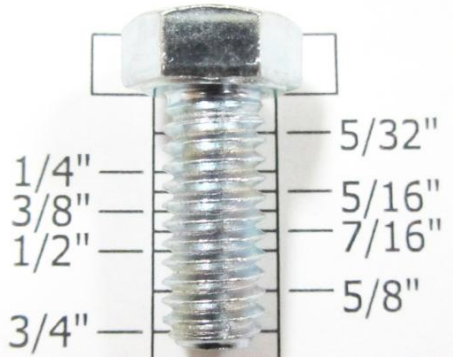
Panel with:

Hardware K				
Part name	Description	Photos	Q'ty	Grainger Model #
Hex Screw	5/16 x 3/4"		60	1YU33
Flat Washer	5/16" x OD23 x 2T		60	*1JY31

(* Hardware item at similar spec available locally.

✦ Installations for WB-5055 (12 booths back to back).

Middle Panel Top Joint

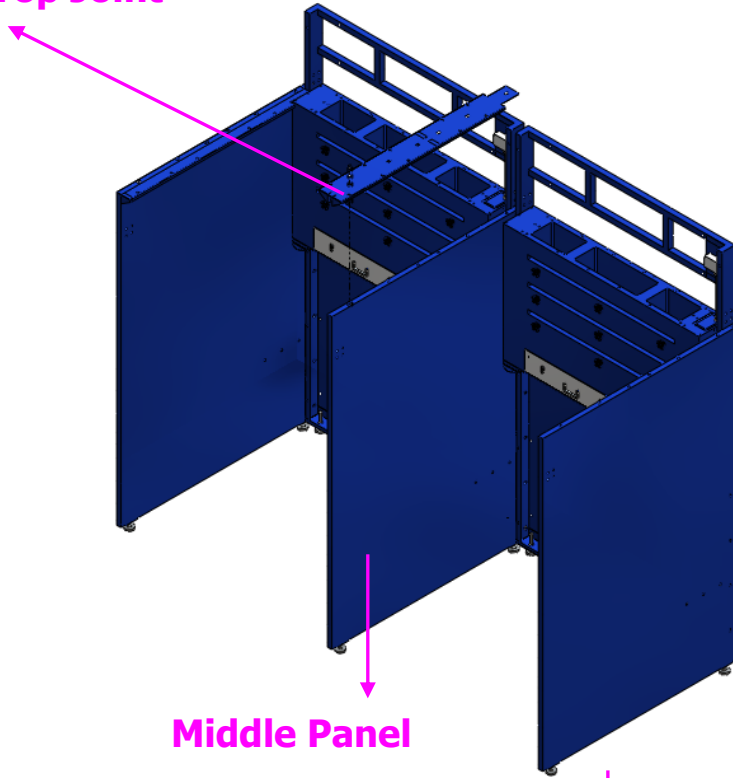

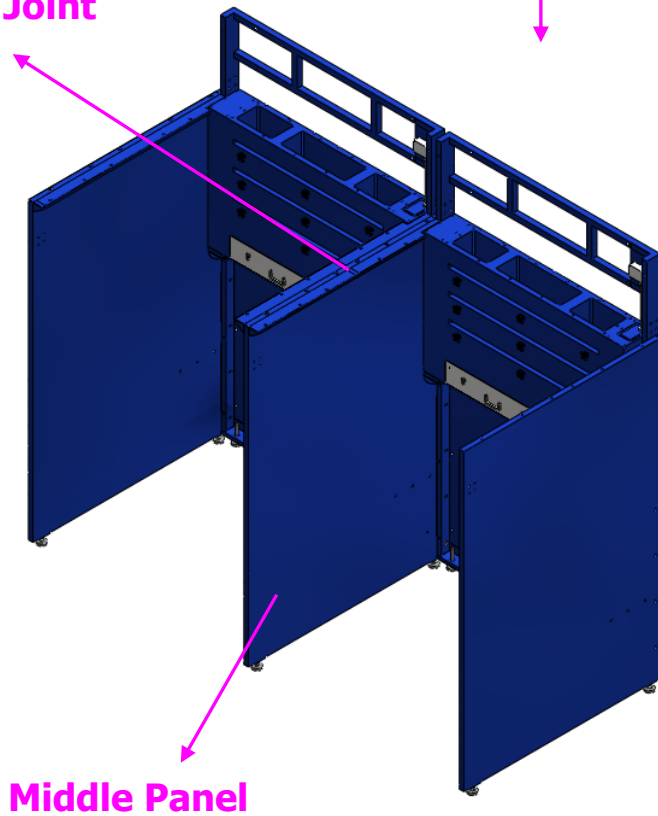

Middle Panel Top Joint



✚ Installations for WB-5055 (12 booths back to back).

- Take out **Right Side Panel Top Joint**.
- Fasten **Right Side Panel Top Joint** adjacent to **Right Side Panel** with:

Hardware L				
Part name	Description	Photos	Q'ty	Grainger Model #
Hex Screw	5/16 x 3/4"		12	1YU33
Flat Washer	5/16" x OD23 x 2T		12	*1JY31

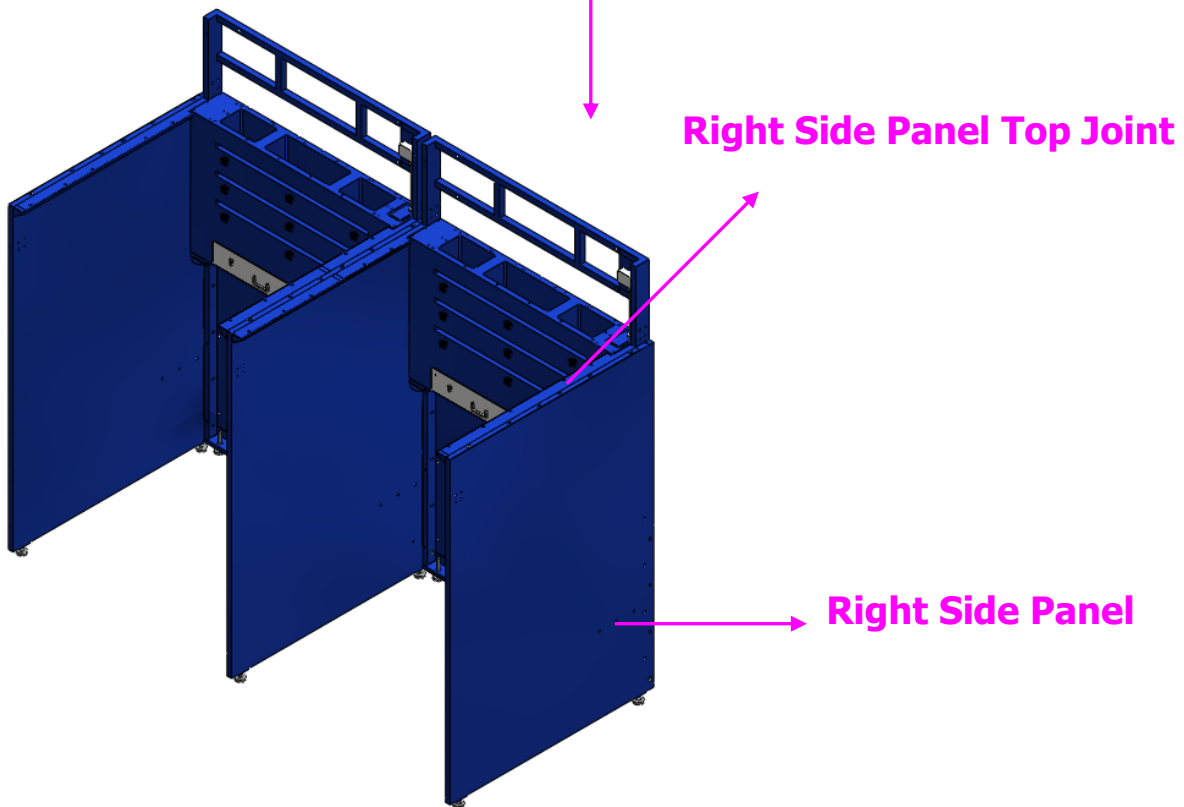
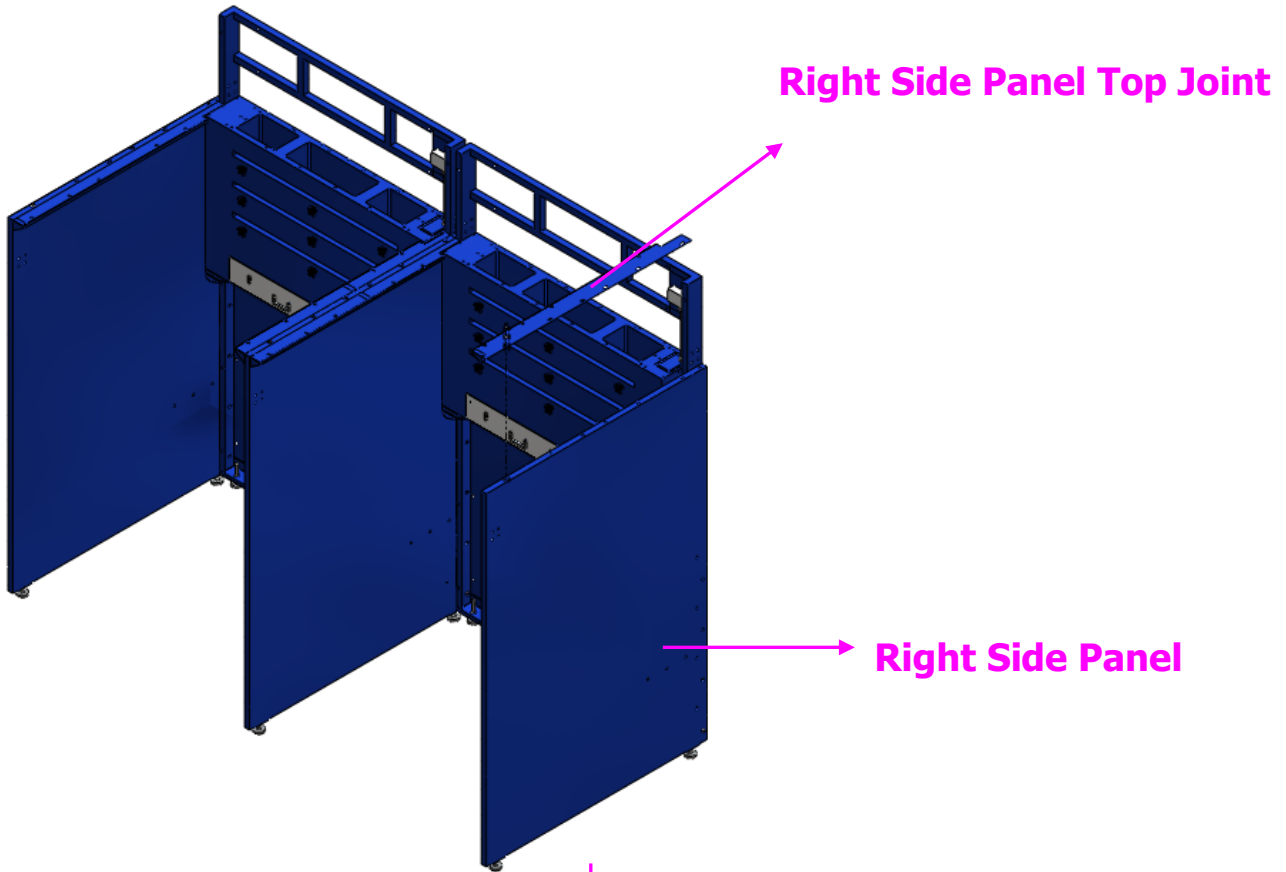

(* Hardware item at similar spec available locally.

✦ Installations for WB-5055 (12 booths back to back).

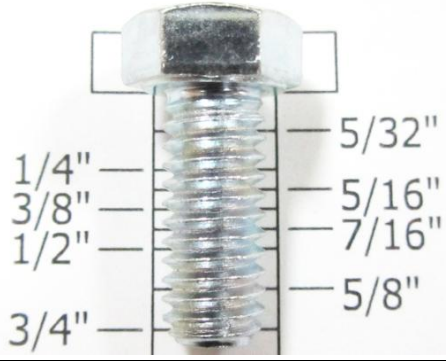

✚ Installations for WB-5055 (12 booths back to back).

- Take out **Top Hood Drafts**.
- Fasten **Top Hood Drafts** adjacent to **Upper Part of the Backdraft** with:

Hardware S				
Part name	Description	Photos	Q'ty	Grainger Model #
Hex Screw	5/16 x 3/4"		168	1YU33
Flat Washer	5/16" x OD23 x 2T		336	*1JY31
Nylon Hex Nut	5/16"		168	3XTK3

(* Hardware item at similar spec available locally.

✚ Installations for WB-5055 (12 booths back to back).

Hex Screw	5/16" x 3/4"		48	1YU33
Flat Washer	5/16" x OD18 2T		48	*1JY31

(*) Hardware item at similar spec available locally.

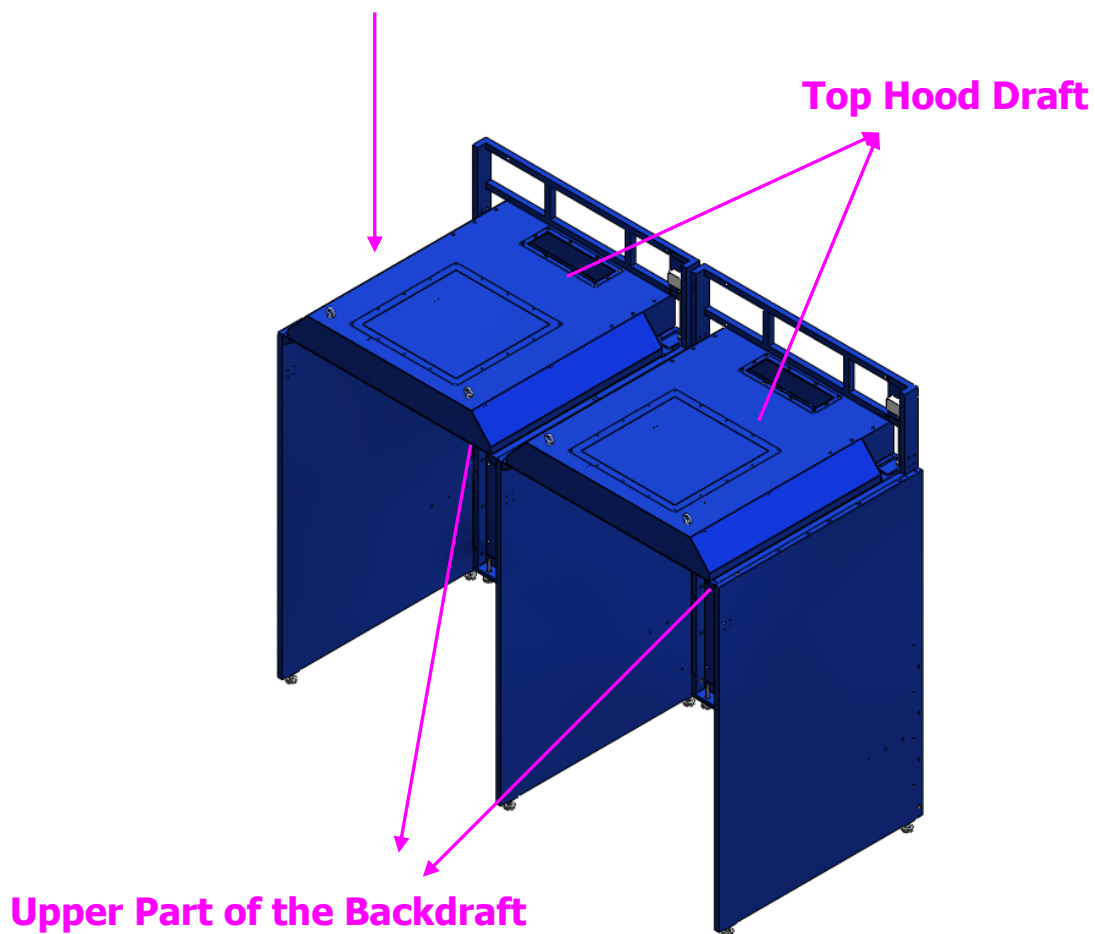
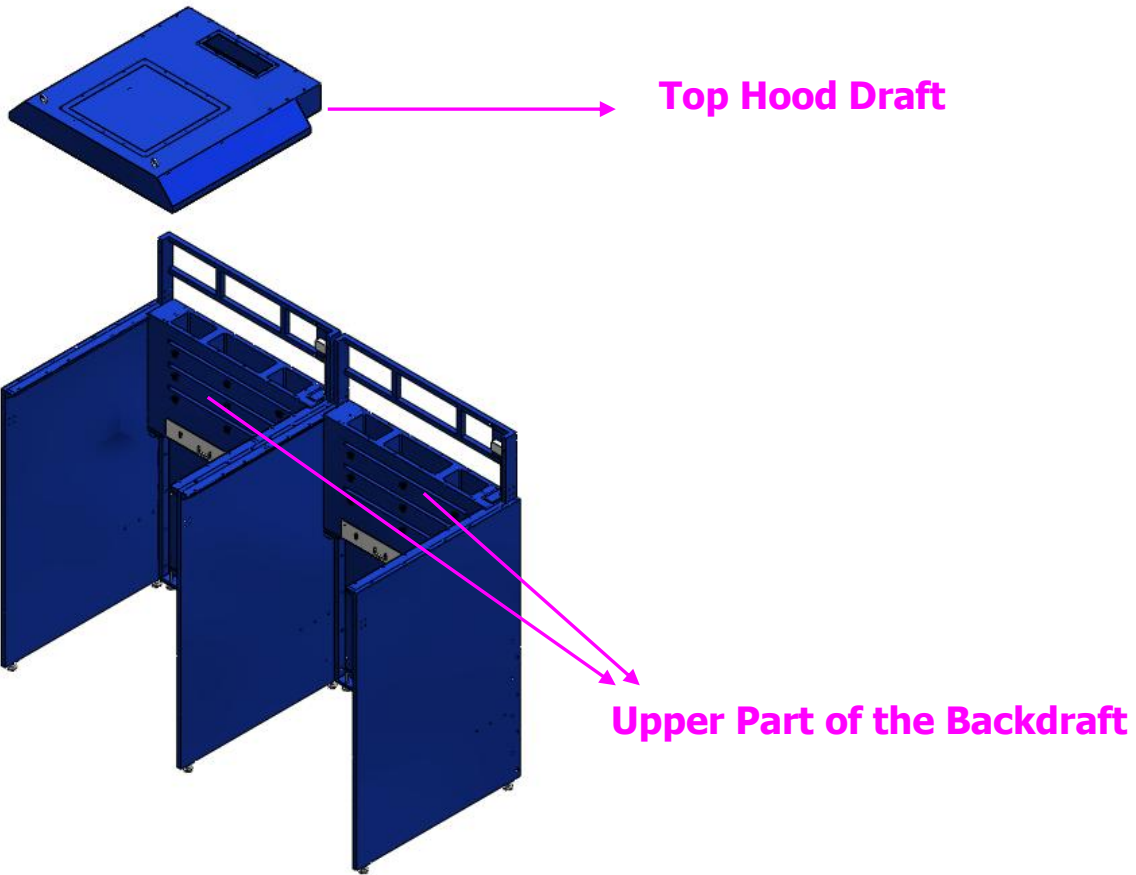

✦ Installations for WB-5055 (12 booths back to back).



✚ Installations for WB-5055 (12 booths back to back).

- Fasten **Top Hood Draft** adjacent to **Left Side Panel Top**

Joint with:

Hardware J				
Part name	Description	Photos	Q'ty	Grainger Model #
Hex Screw	5/16 x 3/4"		10	1YU33
Flat Washer	5/16" x OD23 x 2T		10	*1JY31

(* Hardware item at similar spec available locally.

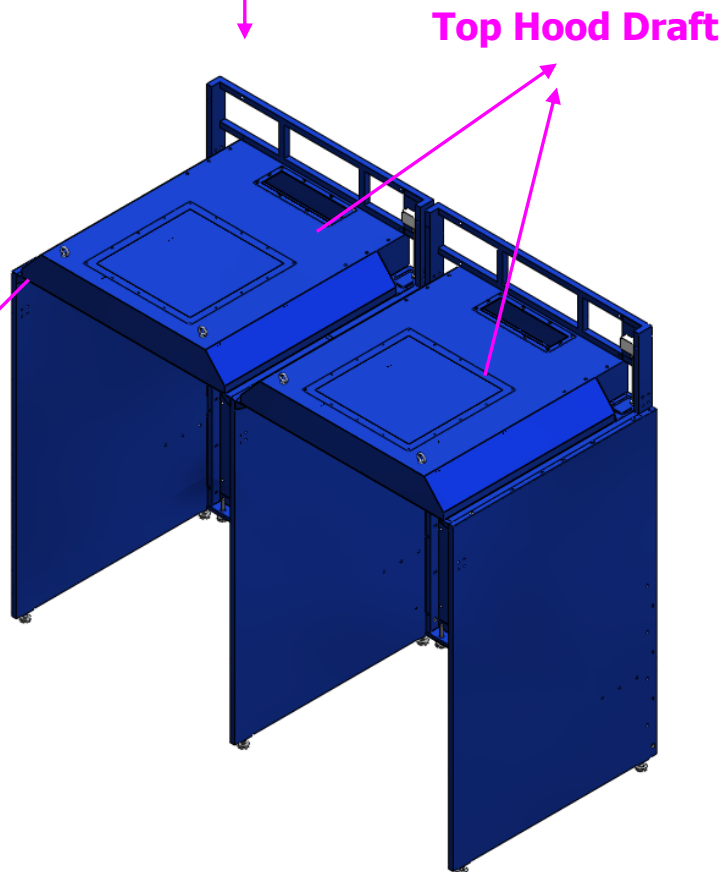
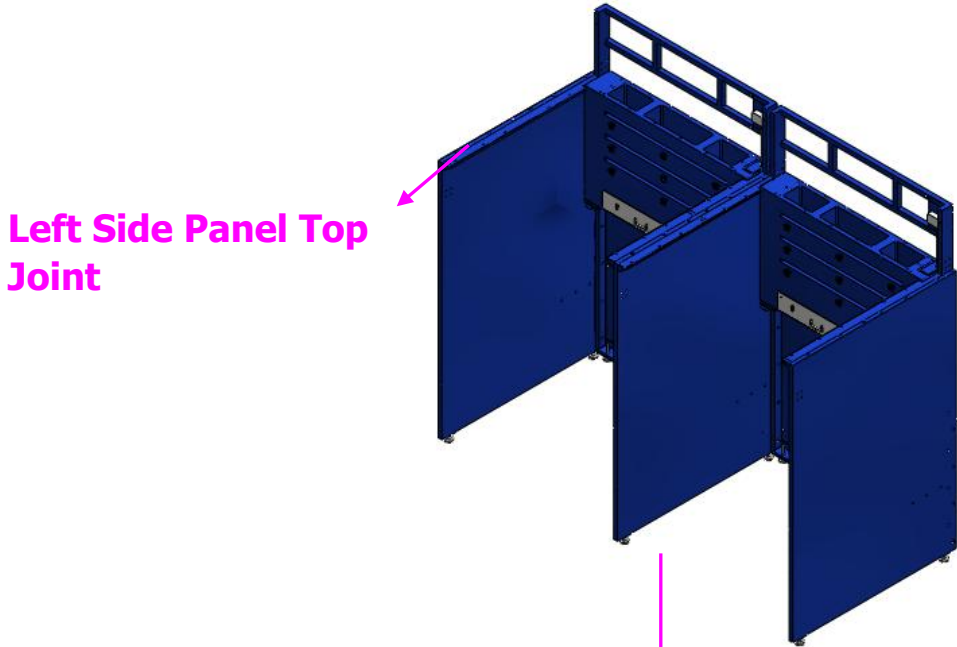
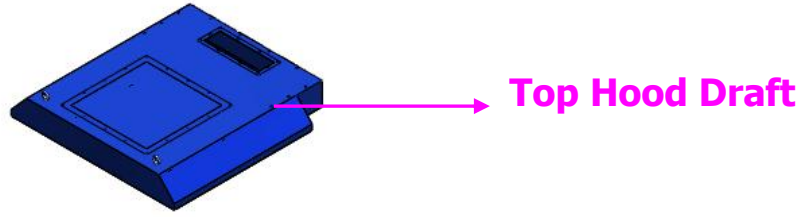

✦ Installations for WB-5055 (12 booths back to back).



✚ Installations for WB-5055 (12 booths back to back).

- Fasten **Top Hood Draft** adjacent to **Middle Panel Top**

Joint with:

Hardware K				
Part name	Description	Photos	Q'ty	Grainger Model #
Hex Screw	5/16 x 3/4"		100	1YU33
Flat Washer	5/16" x OD23 x 2T		100	*1JY31

(* Hardware item at similar spec available locally.

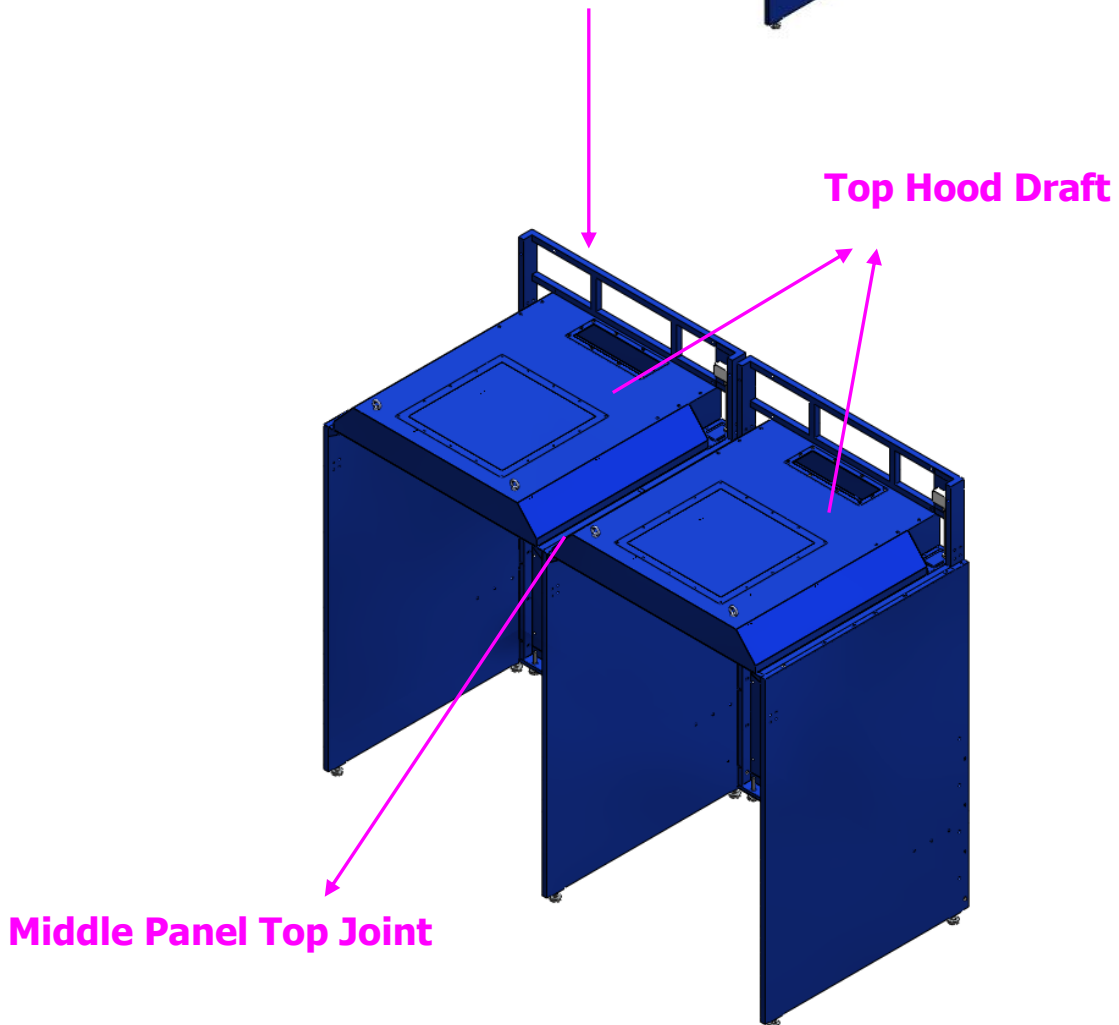
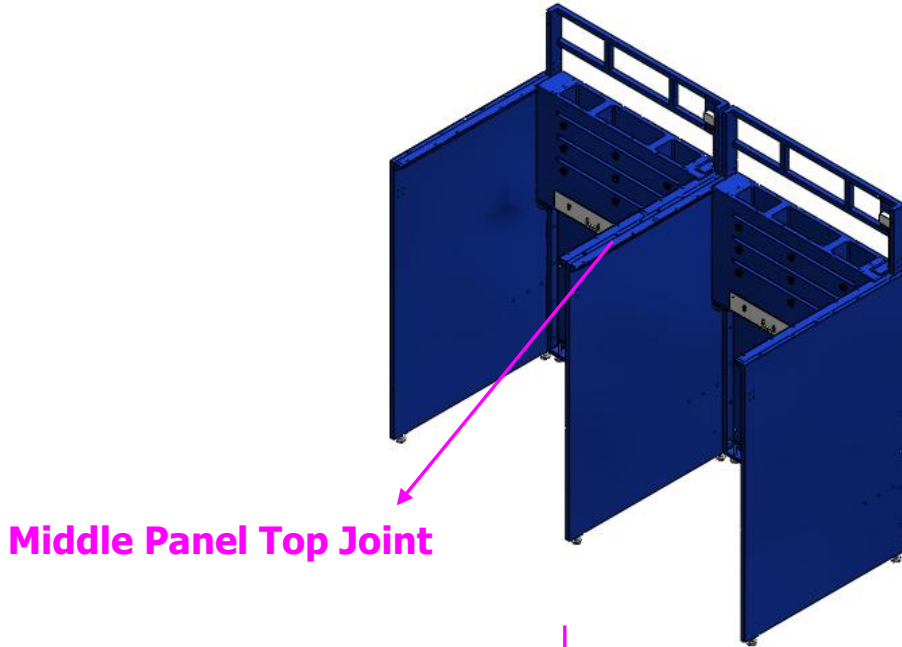
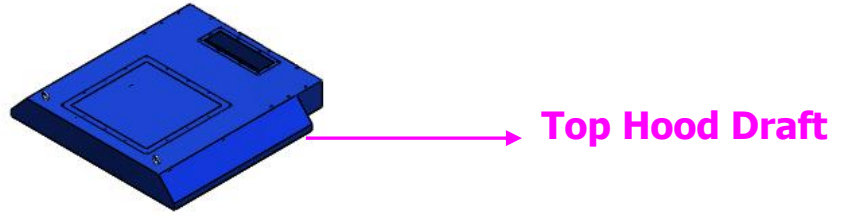

✦ Installations for WB-5055 (12 booths back to back).



✚ Installations for WB-5055 (12 booths back to back).

- Fasten **Top Hood Draft** adjacent to **Right Side Panel**

Top Joint with:

Hardware L				
Part name	Description	Photos	Q'ty	Grainger Model #
Hex Screw	5/16 x 3/4"		10	1YU33
Flat Washer	5/16" x OD23 x 2T		10	*1JY31

(* Hardware item at similar spec available locally.



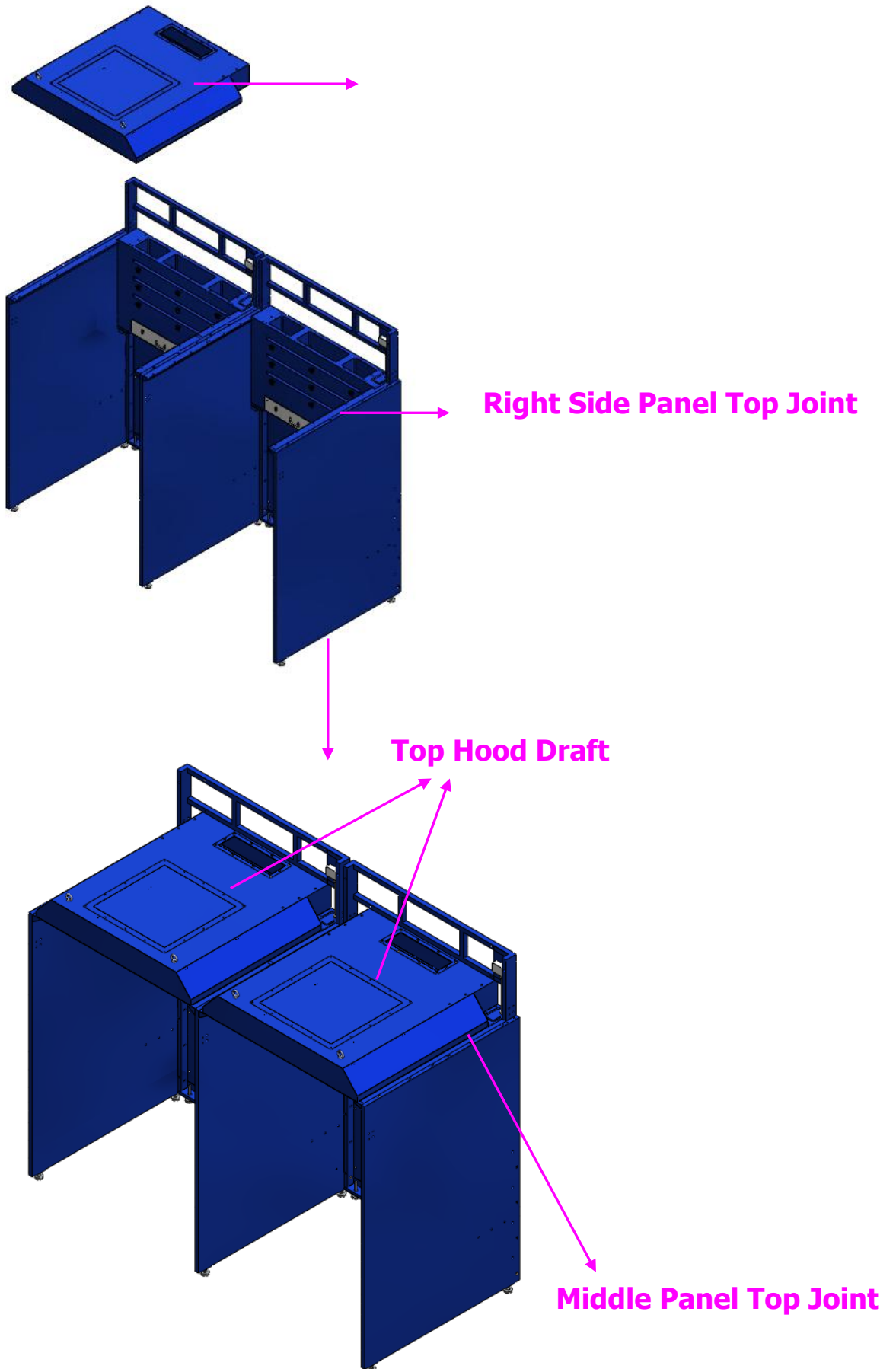

✦ Installations for WB-5055 (12 booths back to back).

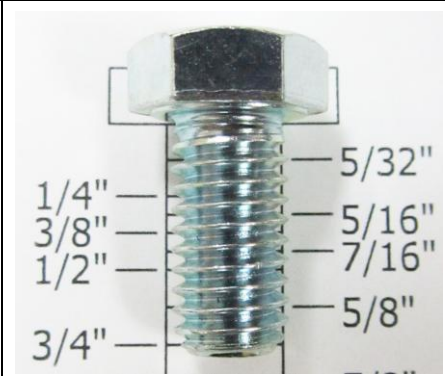

✚ Installations for WB-5055 (12 booths back to back).

- Take out **Fixing Base (left)**.
- Fasten **Fixing Base (left)** adjacent to **Left Side Panel**

with:



Hardware A				
Part name	Description	Photos	Q'ty	Grainger Model #
Hex Screw	3/8 x 3/4"		2	1YU42
Flat Washer	3/8" x OD23 x 2T		2	*1JY33
Hex Screw	5/16 x 3/4"		2	1YU33
Flat Washer	5/16" x OD23 x 2T		2	*1JY31

(*) Hardware item at similar spec available locally.

✚ Installations for WB-5055 (12 booths back to back).

- Fasten **Fixing Base (left)** adjacent to **Upper Part of the Backdraft** with:

Hardware A

Part name	Description	Photos	Q'ty	Grainger Model #
Hex Screw	3/8 x 2-1/2"		4	1YU47
Flat Washer	3/8" x OD23 x 2T		8	*1JY33
Nylon Hex Nut	3/8"		4	3HDU4

(* Hardware item at similar spec available locally.



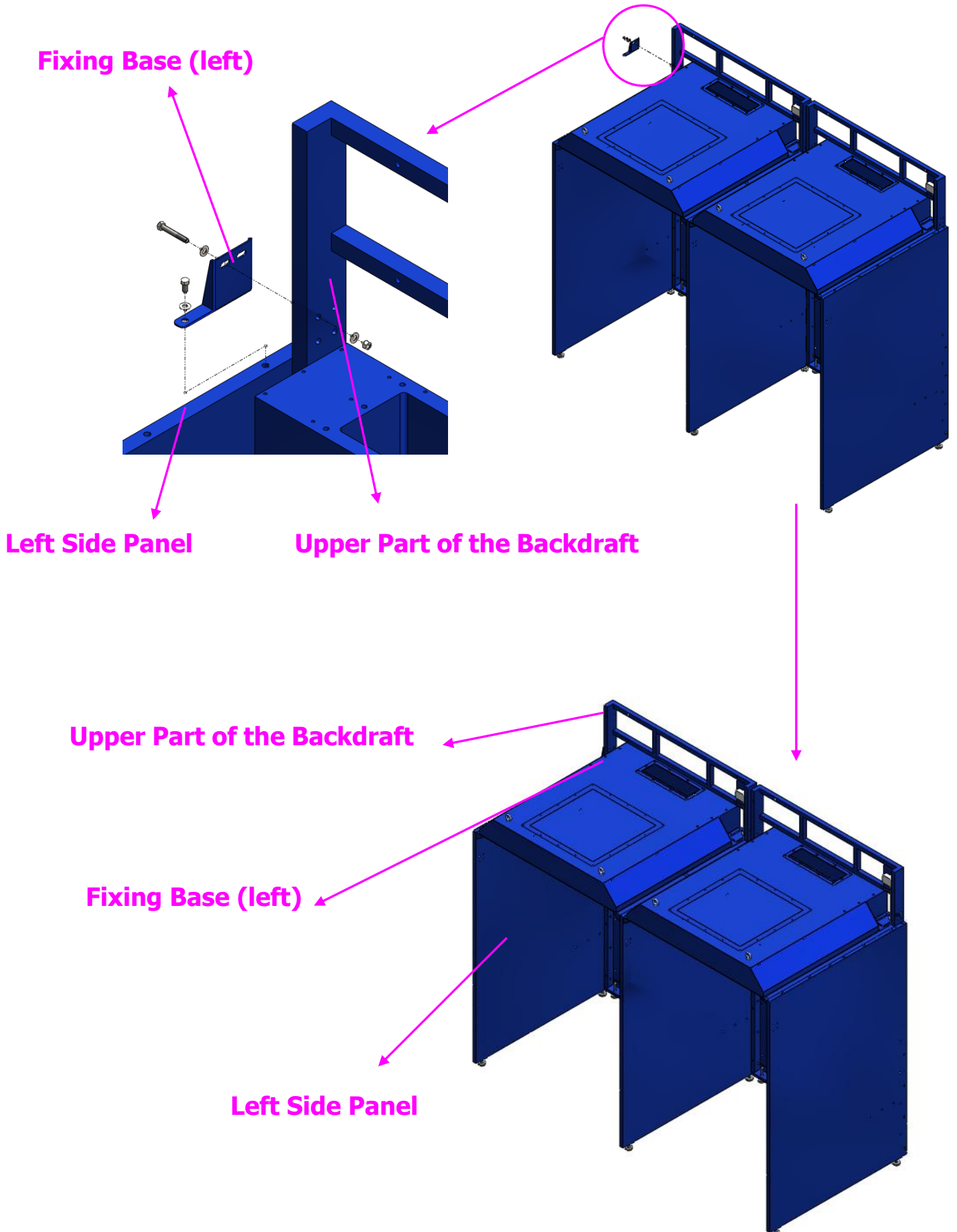

✦ Installations for WB-5055 (12 booths back to back).



✚ Installations for WB-5055 (12 booths back to back).

- Take out **Fixing Base (Right)**.
- Fasten **Fixing Base (Right)** adjacent to **Right Side**



Panel with:

Hardware B				
Part name	Description	Photos	Q'ty	Grainger Model #
Hex Screw	3/8 x 3/4"		2	1YU42
Flat Washer	3/8" x OD23 x 2T		2	*1JY33
Hex Screw	5/16 x 3/4"		2	1YU33
Flat Washer	5/16" x OD23 x 2T		2	*1JY31

(*) Hardware item at similar spec available locally.

✚ Installations for WB-5055 (12 booths back to back).

- Fasten **Fixing Base (Right)** adjacent to **Upper Part of the Backdraft** with:

Hardware A				
Part name	Description	Photos	Q'ty	Grainger Model #
Hex Screw	3/8 x 2-1/2"		4	1YU47
Flat Washer	3/8" x OD23 x 2T		8	*1JY33
Nylon Hex Nut	3/8"		4	3HDU4

(* Hardware item at similar spec available locally.

✦ Installations for WB-5055 (12 booths back to back).

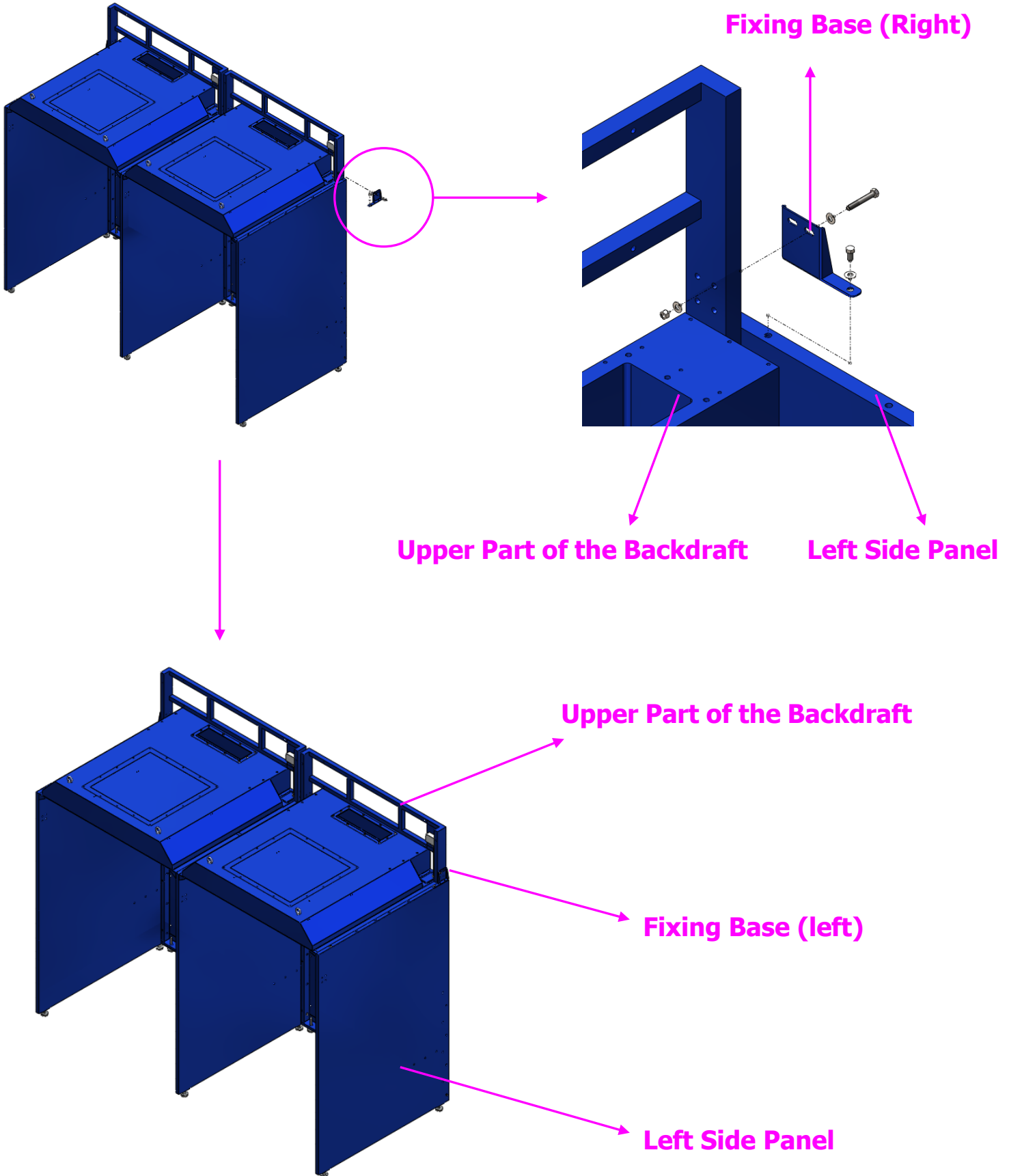

✚ Installations for WB-5055 (12 booths back to back).

- Take out **Triangular Rear Support (Left)**.
- Fasten **Triangular Rear Support (Left)** adjacent to

Upper Part of the Backdraft with:



Hardware H				
Part name	Description	Photos	Q'ty	Grainger Model #
Hex Screw	5/16 x 3/4"		24	1YU33
Flat Washer	5/16" x OD23 x 2T		48	*1JY31
Nylon Hex Nut	5/16"		24	3XTK3

(* Hardware item at similar spec available locally.

✦ Installations for WB-5055 (12 booths back to back).

- Fasten **Triangular Rear Support (Left)** adjacent to **Top**

Hood Draft with:

Hardware H				
Part name	Description	Photos	Q'ty	Grainger Model #
Hex Screw	5/16 x 3/4"		36	1YU33
Flat Washer	5/16" x OD23 x 2T		36	*1JY31

(* Hardware item at similar spec available locally.

✚ Installations for WB-5055 (12 booths back to back).

- Take out **Triangular Rear Support (Right)**.
- Fasten **Triangular Rear Support (Right)** adjacent to **Upper Part of the Backdraft** with:



Hardware G				
Part name	Description	Photos	Q'ty	Grainger Model #
Hex Screw	5/16 x 3/4"		24	1YU33
Flat Washer	5/16" x OD23 x 2T		48	*1JY31
Nylon Hex Nut	5/16"		24	3XTK3

(* Hardware item at similar spec available locally.

✚ Installations for WB-5055 (12 booths back to back).

- Fasten **Triangular Rear Support (Right)** adjacent to **Top Hood Draft** with:

Hardware G

Part name	Description	Photos	Q'ty	Grainger Model #
Hex Screw	5/16 x 3/4"		36	1YU33
Flat Washer	5/16" x OD23 x 2T		36	*1JY31

(* Hardware item at similar spec available locally.

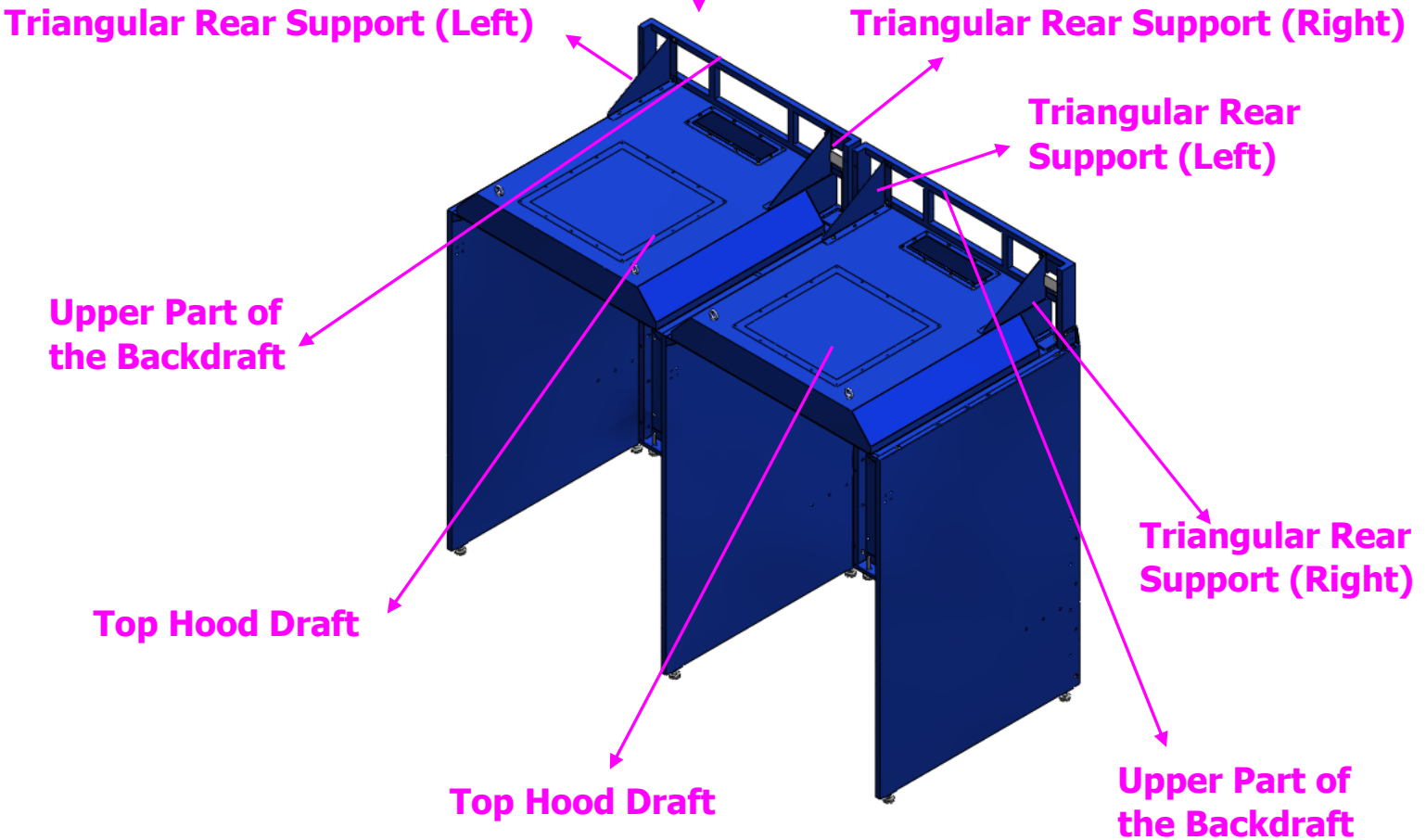
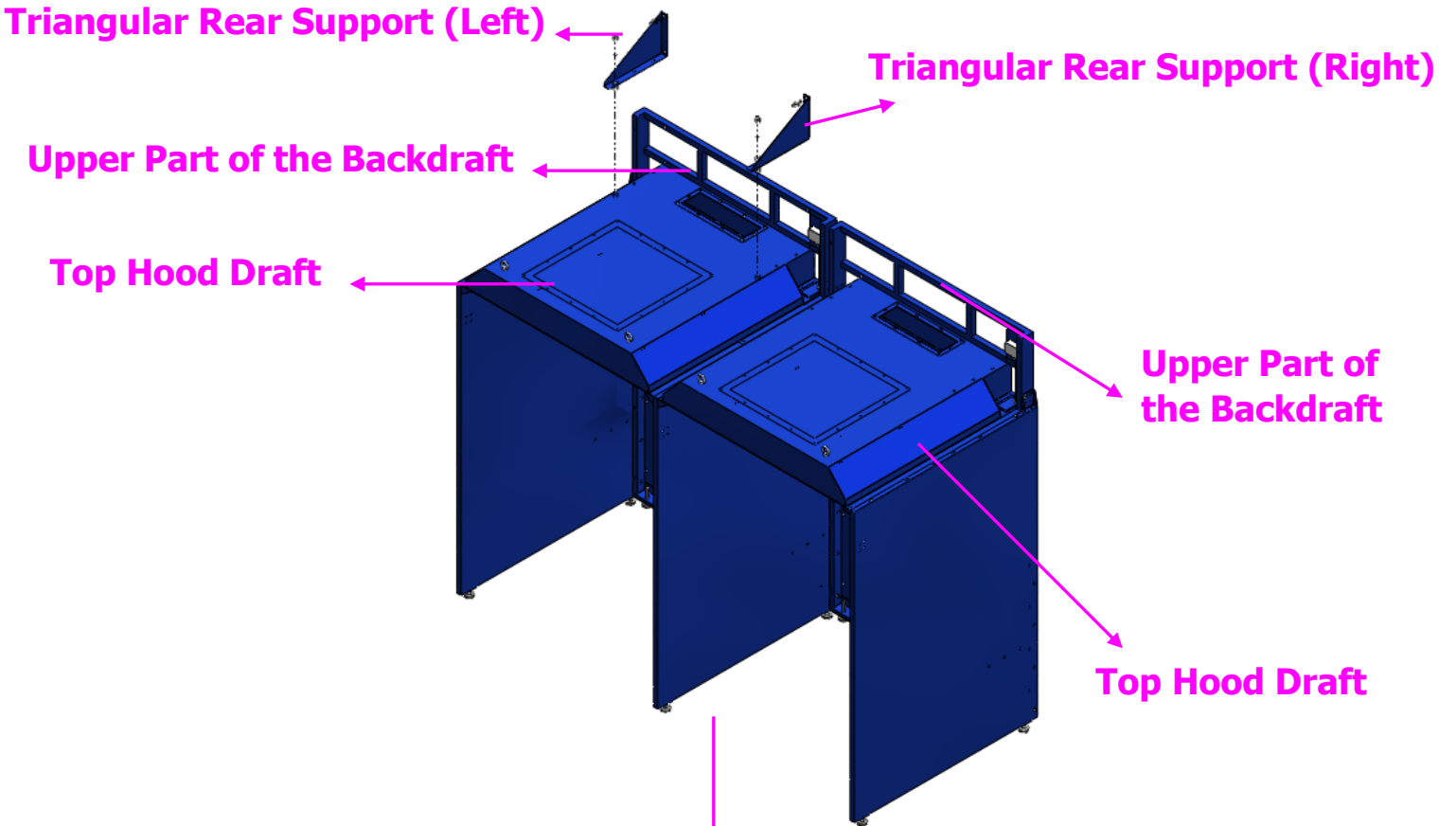

✦ Installations for WB-5055 (12 booths back to back).



✚ Installations for WB-5055 (12 booths back to back).

- Take out **Adjustable Backshelf (solid)**.
- Fasten **Adjustable Backshelf (solid)** adjacent to **Booth**

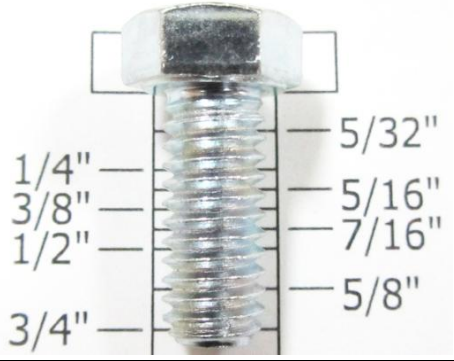
with:

Hardware F				
Part name	Description	Photos	Q'ty	Grainger Model #
Hex Screw	5/16 x 3/4"		96	1YU33
Flat Washer	5/16" x OD23 x 2T		96	*1JY31

(* Hardware item at similar spec available locally.

✦ Installations for WB-5055 (12 booths back to back).

Adjustable Backshelf (solid)

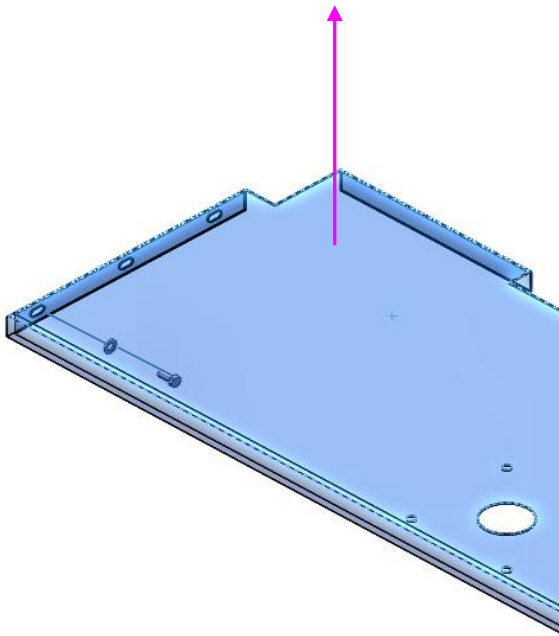

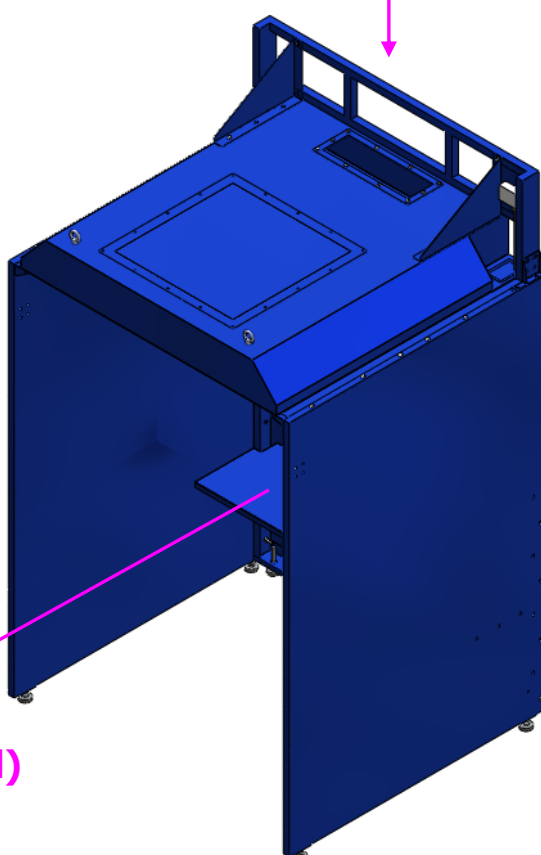
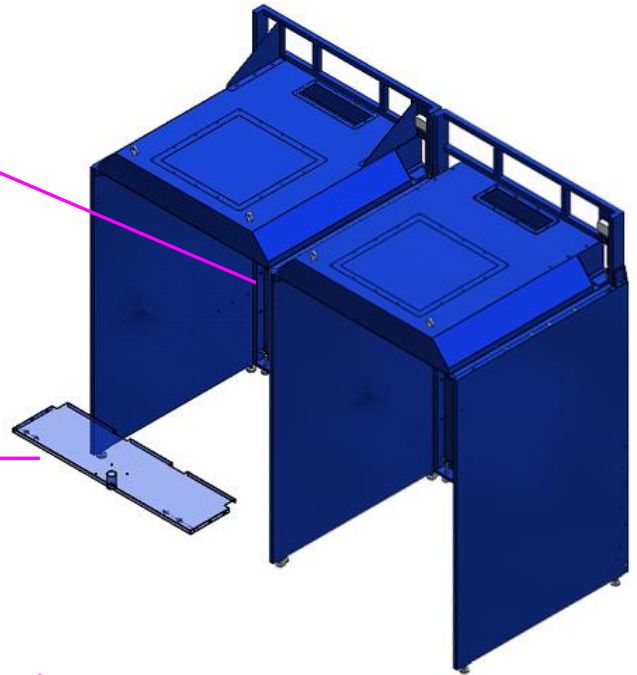

Booth



Adjustable Backshelf (solid)

✚ Installations for WB-5055 (12 booths back to back).

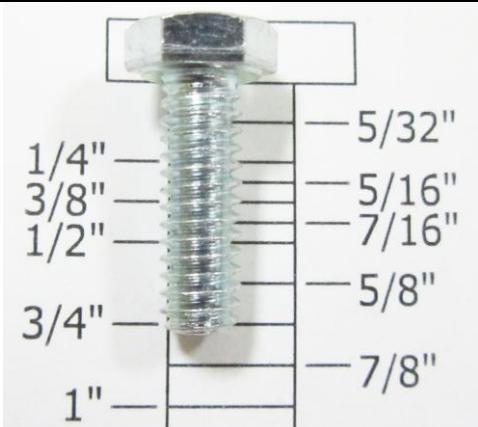
- Take out **Curtain Rod**.
- Fasten **Curtain Rod** adjacent to **Left Side Panel, Middle Panel** and **Right Side Panel** with:

Hardware N				
Part name	Description	Photos	Q'ty	Grainger Model #
Hex Screw	1/4" x 3/4"		192	1YU24
Flat Washer	1/4" x OD19 x 2T		192	*1JY29

(* Hardware item at similar spec available locally.

Installations for WB-5055 (12 booths back to back).

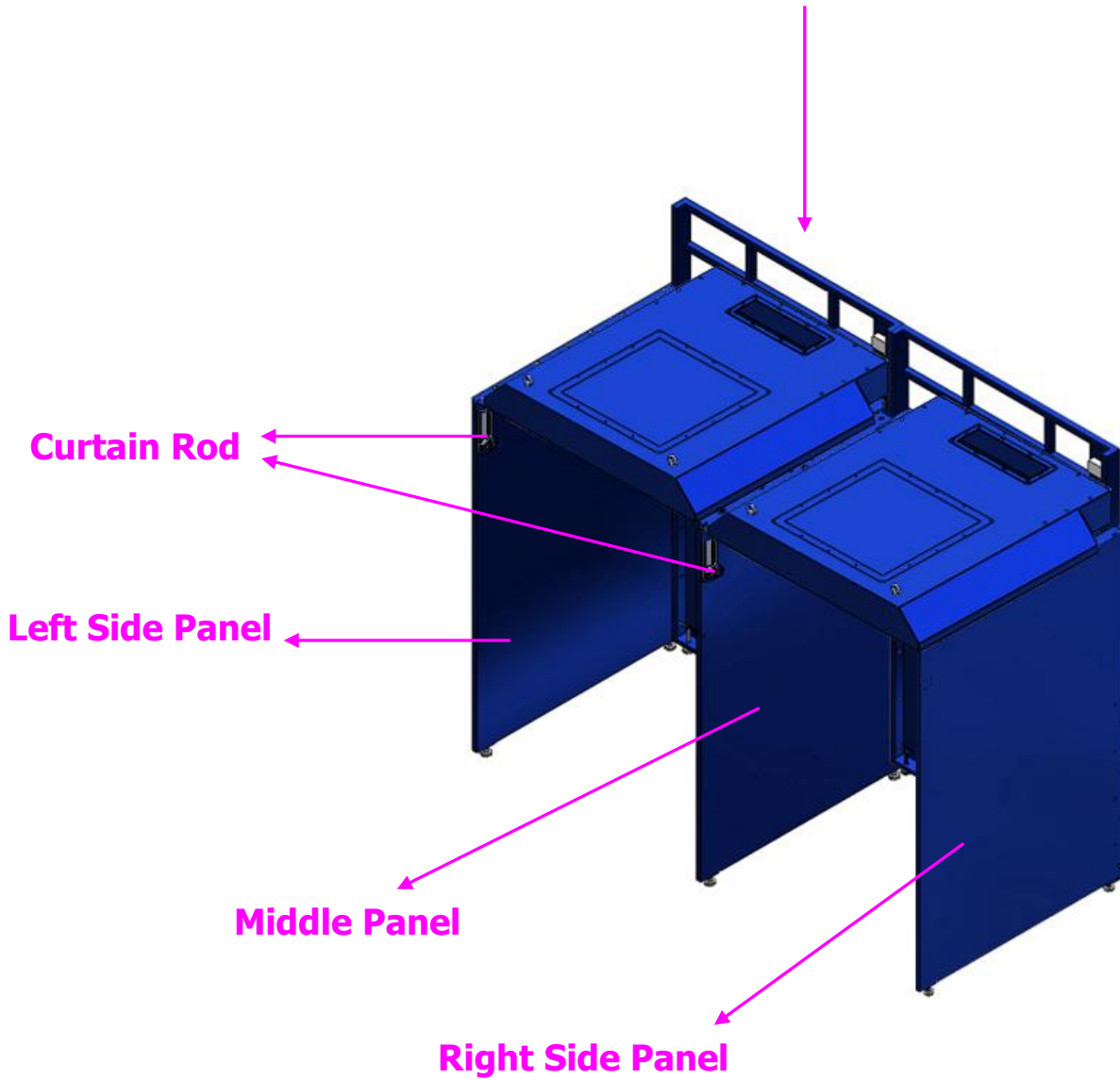
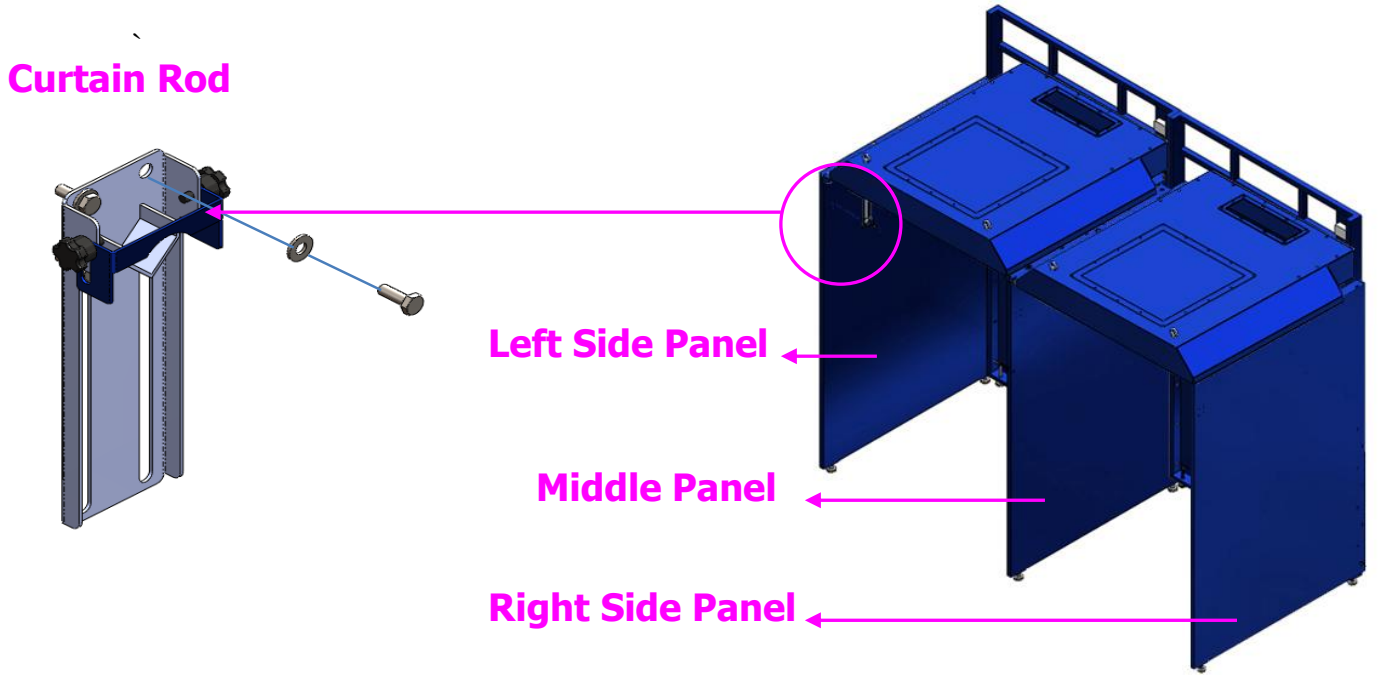

Curtain Rod



✚ Installations for WB-5055 (12 booths back to back).

- Take out **Working Lights**.
- Fasten **Working Lights** adjacent to **Top Hood Draft**

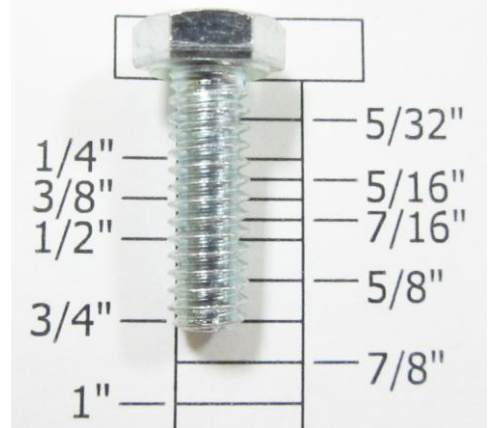
with:

Hardware M				
Part name	Description	Photos	Q'ty	Grainger Model #
Hex Screw	1/4" x 3/4"		96	1YU24
Flat Washer	1/4" x OD19 x 2T		96	*1JY29

(* Hardware item at similar spec available locally.

✦ Installations for WB-5055 (12 booths back to back).

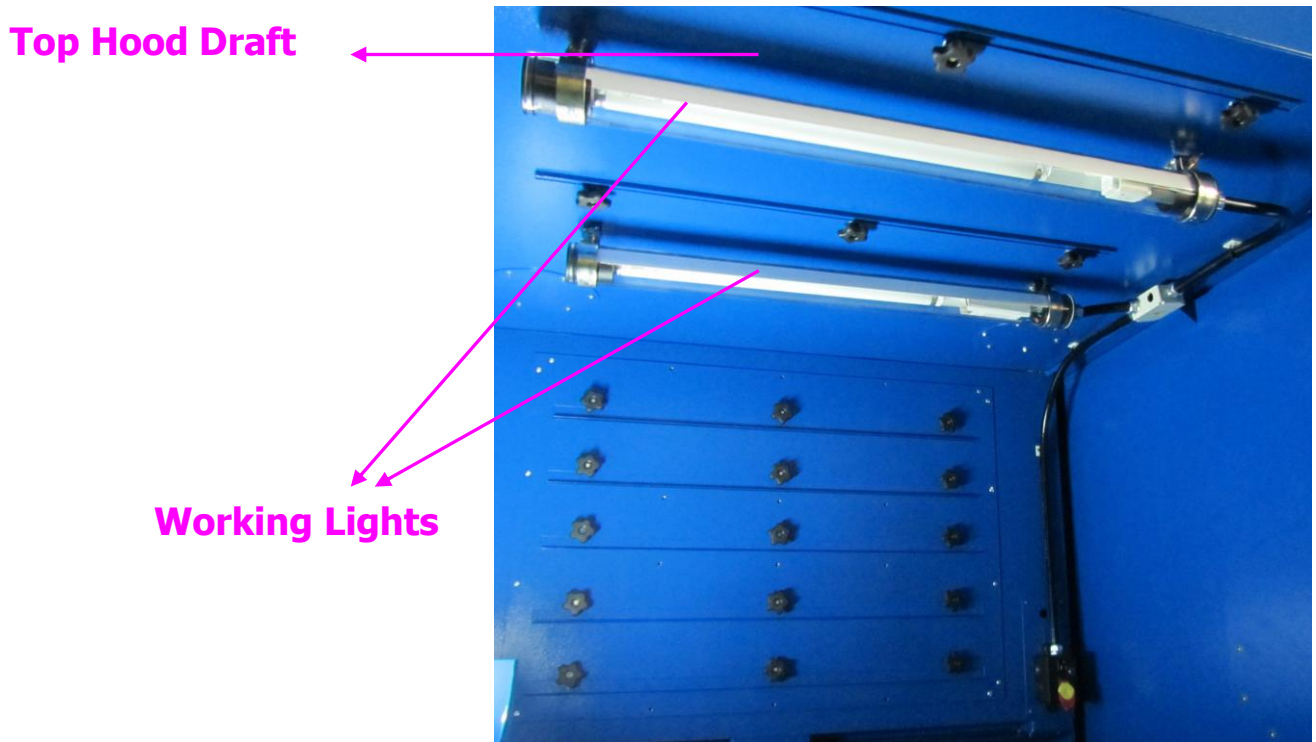
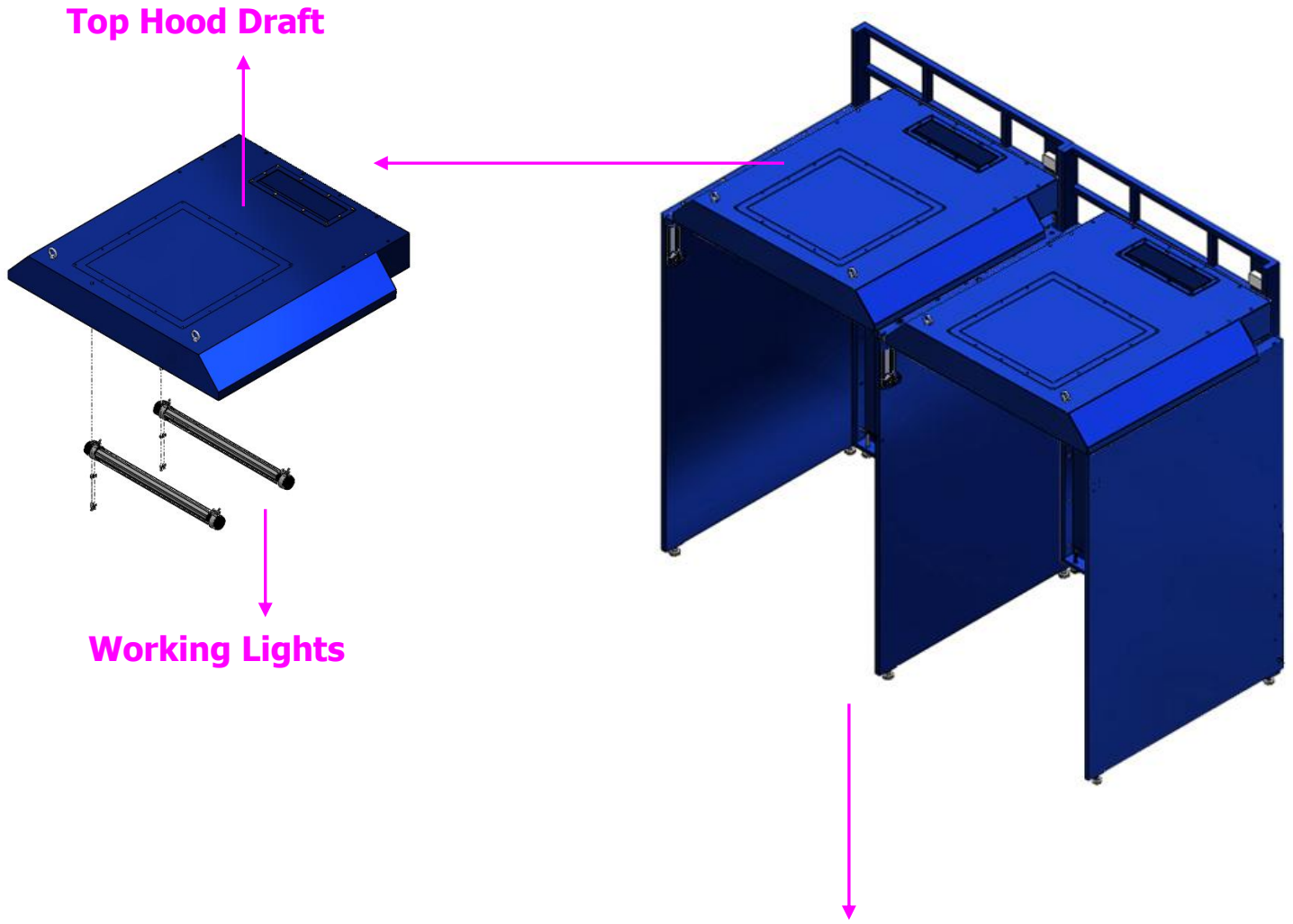

✚ Installations for WB-5055 (12 booths back to back).

- Fasten **Cable Connector Panel (front)** adjacent to **Upper Part of the Backdraft**.

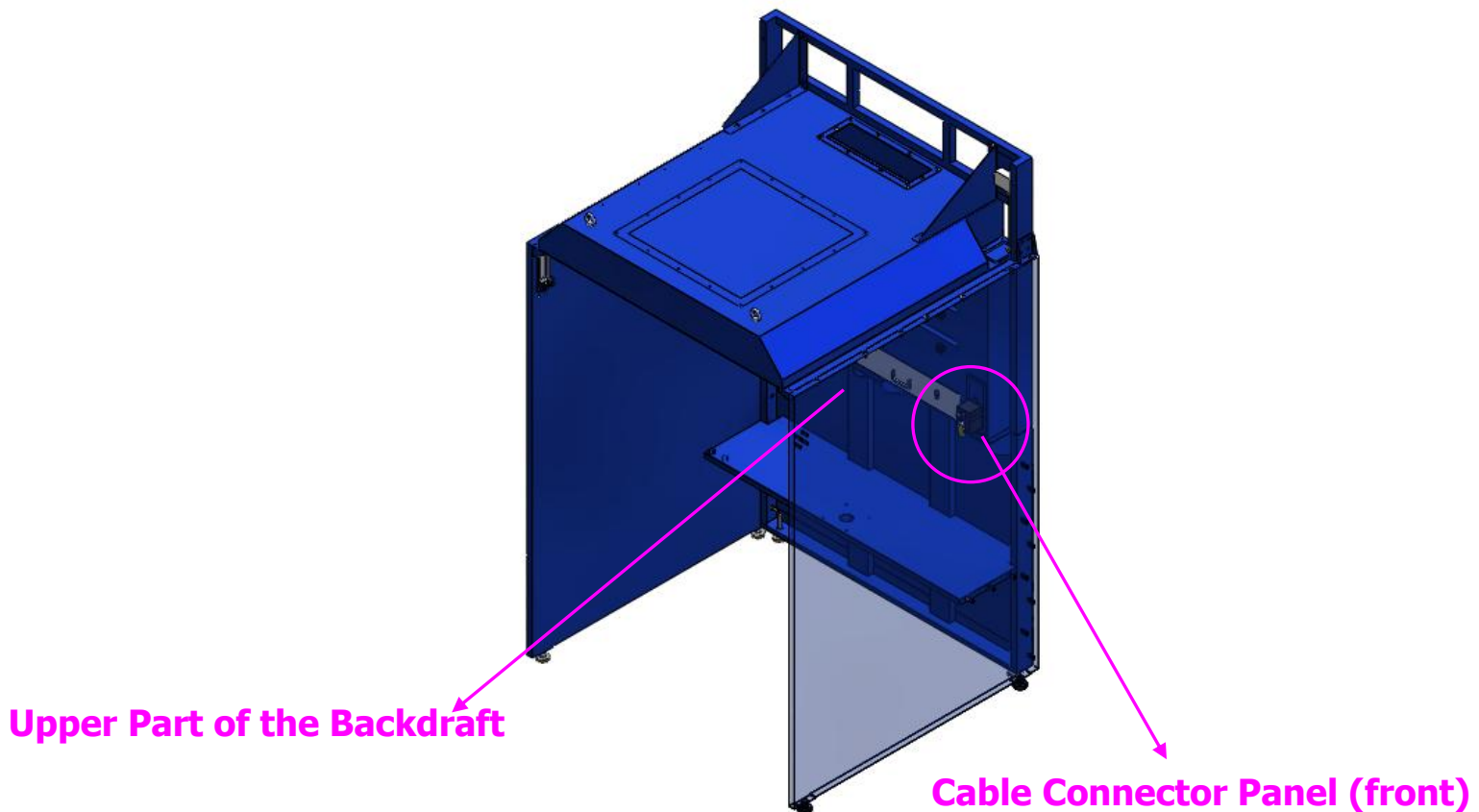
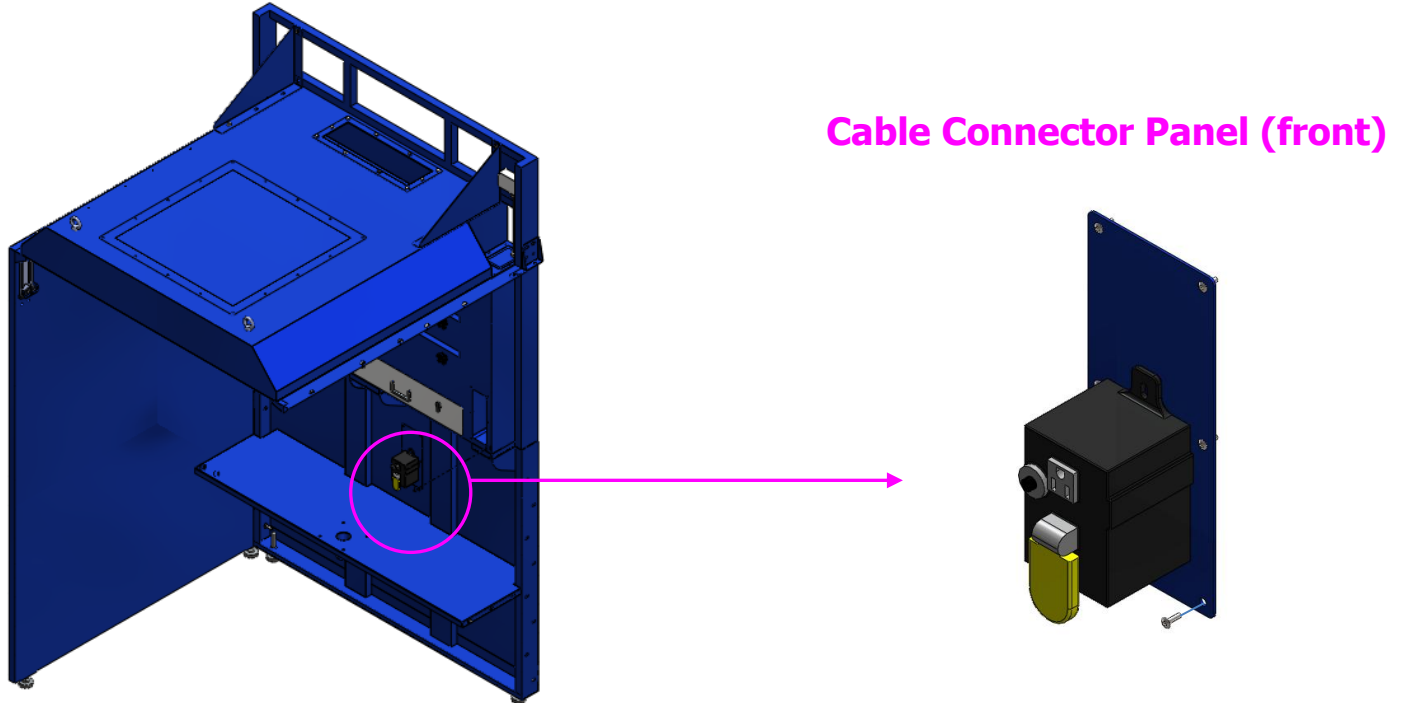

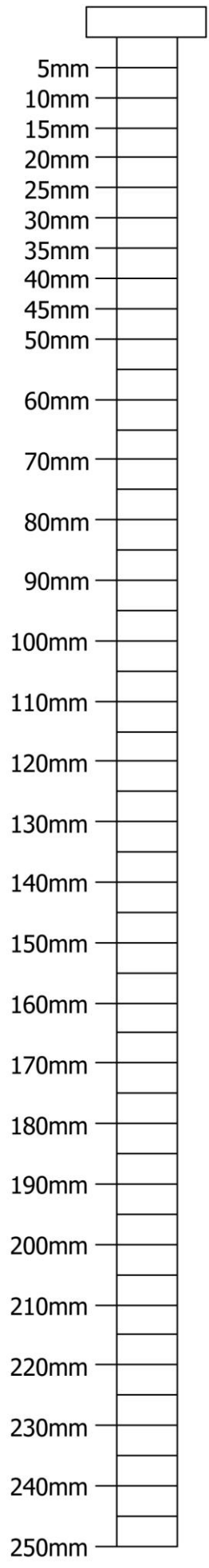
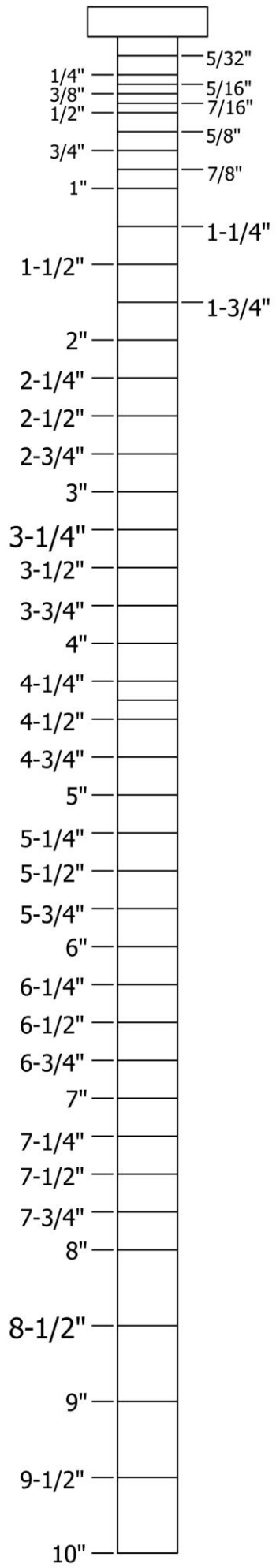

Flat Washwe: 1/4"

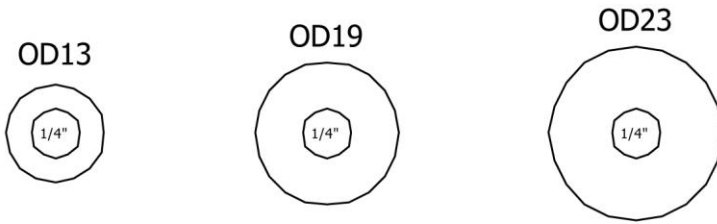

Flat Washwe: 5/16"

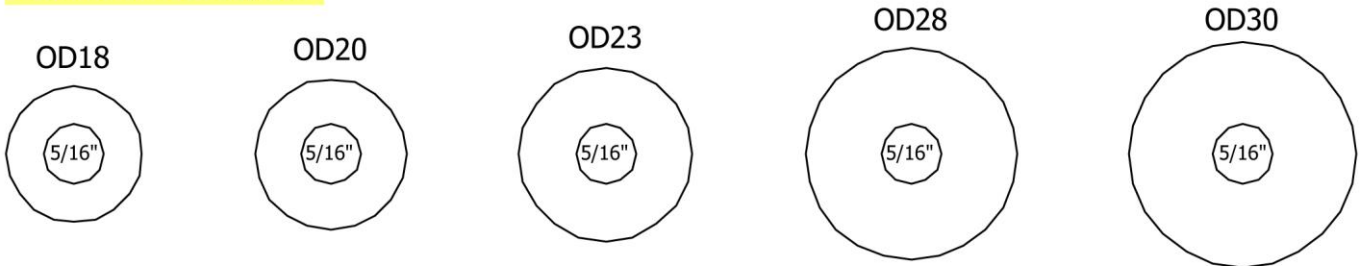

Flat Washwe: 3/8"

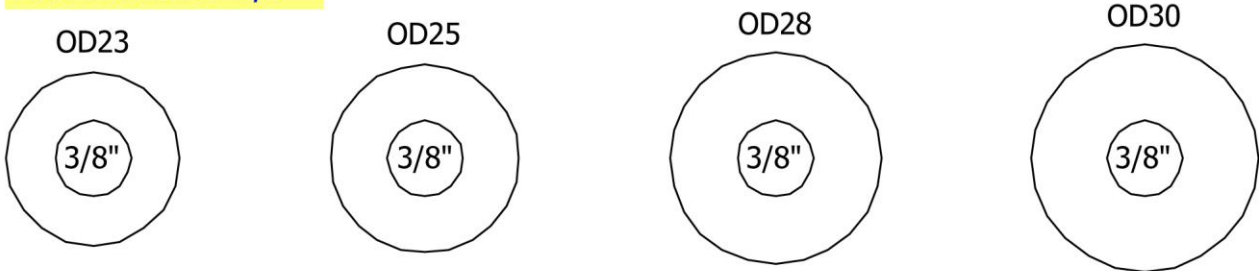

Flat Washwe: 1/2"

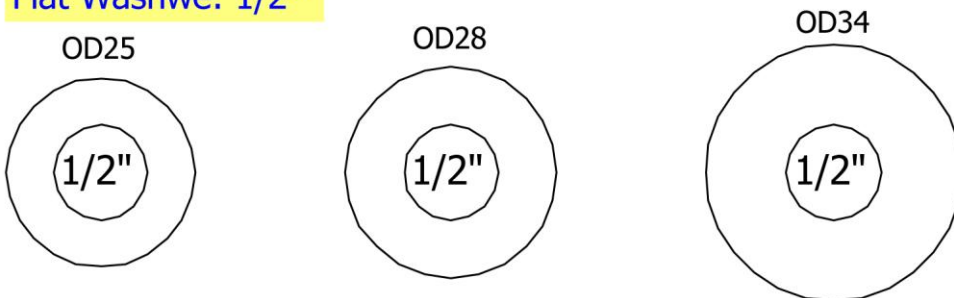

Flat Washwe: 7/16"

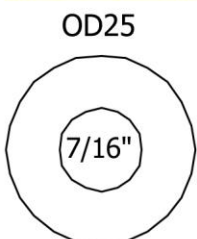

Flat Washwe: 5/8"

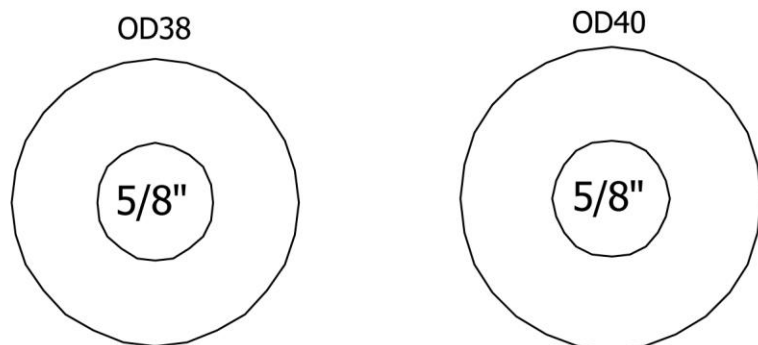

HEX NUT

3/16"



HEX NUT

1/4"



HEX NUT

5/16"



HEX NUT

3/8"



HEX NUT

1/2"

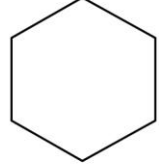

HEX NUT

NYLON HEX NUT

1/4"



NYLON HEX NUT

5/16"



NYLON HEX NUT

3/8"



NYLON HEX NUT

1/2"



NYLON HEX NUT

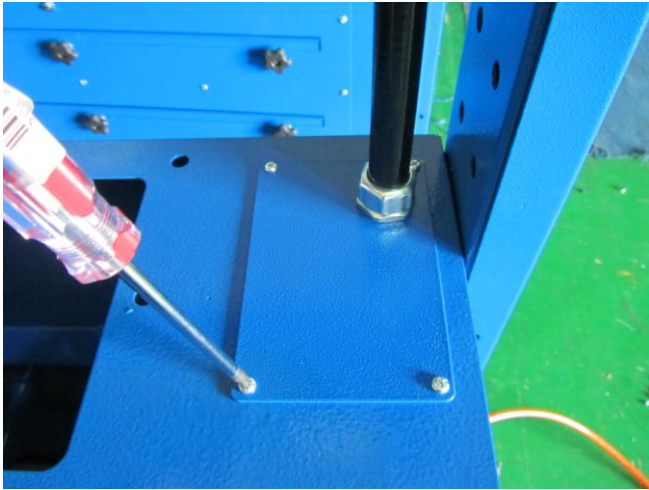

◆ Loose the iron plate with the screwdriver.

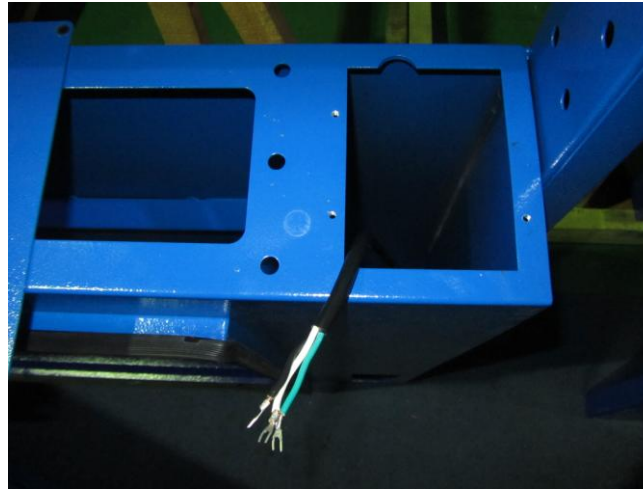

◆ From the wireway, take out the cable of light switch.

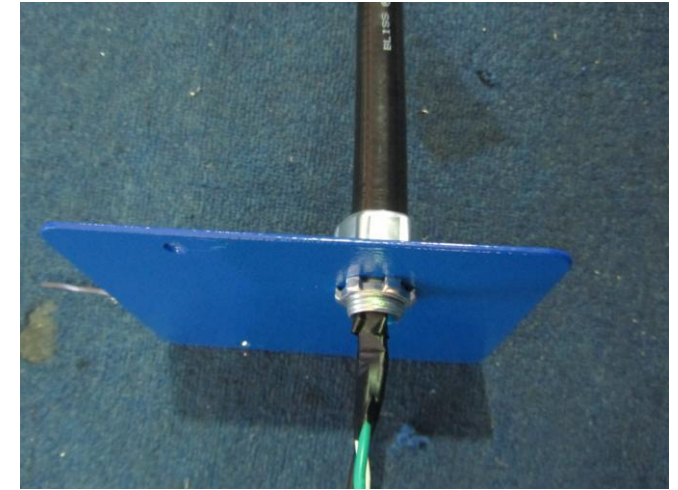

◆ Insert the cable of the light switch through the flexible steel conduit into the electrical junction box.

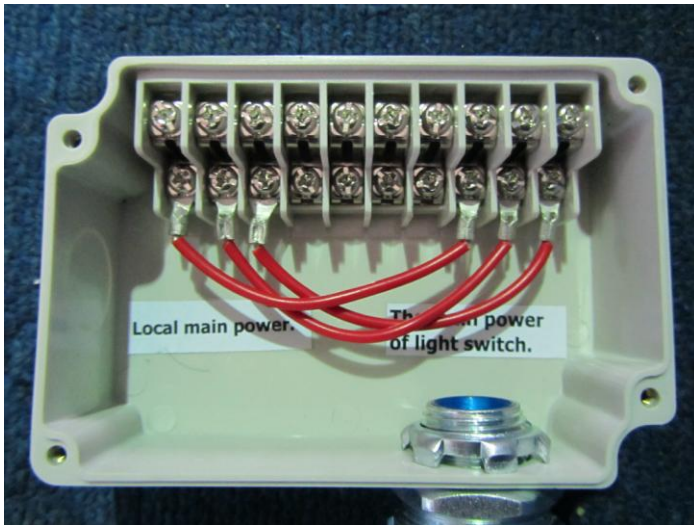

◆ Open the cover of the electrical junction box.

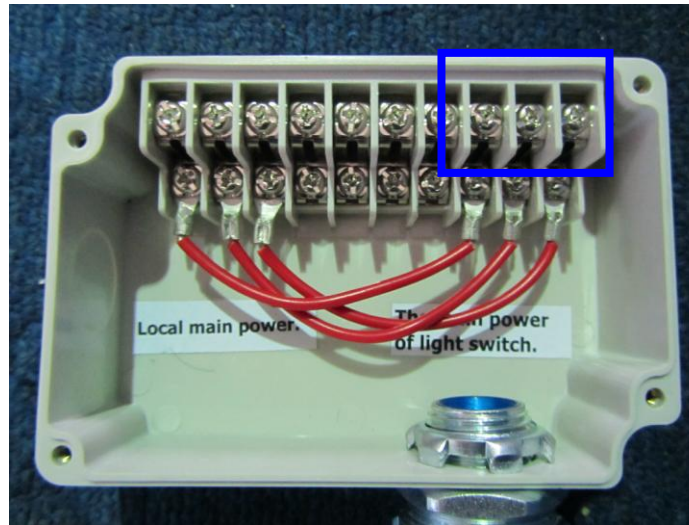

◆ Connect the cable of the light switch with terminal blocks.

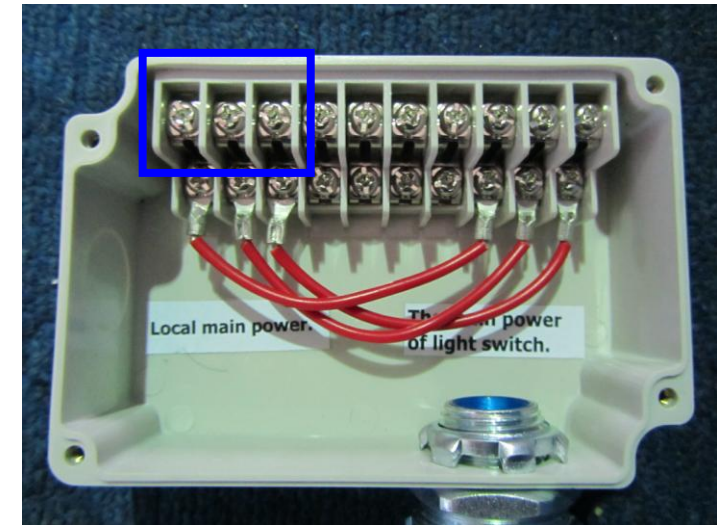

◆ Link this set to local main power supply.

The wiring of light switch

The cable of light switch

