

ISOMETRIC VIEW
SCALE: 1/4"=1'-0"

		PARTS LIST	
ITEM	QTY	PART NUMBER	DESCRIPTION
1	2	JUNKER-1	Junker Grinder - BY OTHERS
2	1	11301339	Elbow, 300mm dia., 90deg., R=1D, 1mm thk., carbon steel
3	2	11201339	Elbow, 200mm dia., R=1D, 1.5mm thk., carbon steel
4	2	11151339	Elbow, 150mm dia., 90deg., R=1D, 1mm thk., carbon steel
5	2	11201346	Elbow, 200mm dia., 60deg., R=2D, 1mm thk., carbon steel
6	2	11151346	Elbow, 150mm dia., 60deg., R=2D, 1mm thk., carbon steel
7	2	11201255	Lateral Conical, 200mm x 150mm x 150mm, 1.5mm, carbon steel
8	1	11251275	Y-branch, conical, symmetrical, 60deg, 250mm x 200mm x 200mm, 1.5mm, carbon steel
9	1	11001475	Cone Adapter, 250mm x 300mm, 1.5mm, carbon steel
10	1	11301020	Tube, 300mm dia., 1000mm lg. (nominal), 1mm thk., carbon steel
11	4	11201010	Tube, 200mm dia., 2000mm lg. (nominal), 1mm thk., carbon steel
12	4	11201030	Tube, 200mm dia., 500mm lg. (nominal), 1mm thk., carbon steel
13	2	11151010	Tube, 150mm dia., 2000mm lg. (nominal), 1mm thk., carbon steel
14	2	11151020	Tube, 150mm dia., 1000mm lg. (nominal), 1mm thk., carbon steel
15	2	11151040	Tube, 150mm dia., 200mm lg., 1mm thk., carbon steel
16	4	11151030	Tube, 150mm dia., 500mm lg. (nominal), 1mm thk., carbon steel
17	1	11301110	Slip Tube, 300mm dia., 1000mm lg. (nominal), 1.5mm thk., carbon steel
18	4	11201110	Slip Tube, 200mm dia., 1000mm lg. (nominal), 1.5mm thk., carbon steel
19	2	11151110	Slip Tube, 150mm dia., 1000mm lg. (nominal), 1.5mm thk., carbon steel
20	4	11151120	Slip Tube, 150mm dia., 500mm lg. (nominal), 1.5mm thk., carbon steel
21	1	12301060	End Welding, 300mm, 55mm lg., 2mm thk., carbon steel
22	4	12151060	End Welding, 150mm, 55mm lg., 2mm thk., carbon steel
23	4	12302903	Quick connect pull ring, 300mm dia., for 1mm-2mm tubing, galvanized
24	1	12252903	Quick connect pull ring, 250mm dia., for 1mm-2mm tubing, galvanized
25	18	12202903	Quick connect pull ring, 200mm dia., for 1mm-2mm tubing, galvanized
26	24	12152903	Quick connect pull ring, 150mm dia., for 1mm-2mm tubing, galvanized
27	3	10306951	U-shaped gasket, 300mm dia., for 1mm tubing, Perbunan (NBR)
28	1	10256951	U-shaped gasket, 250mm dia., for 1mm tubing, Perbunan (NBR)
29	14	10206951	U-shaped gasket, 200mm dia., for 1mm tubing, Perbunan (NBR)
30	18	10156951	U-shaped gasket, 150mm dia., for 1mm tubing, Perbunan (NBR)
31	1	10306155	Ring seal for slip tubes 1.5mm thick, 300mm dia., Perbunan (NBR)
32	4	10206155	Ring seal for slip tubes 1.5mm thick, 200mm dia., Perbunan (NBR)
33	6	10156155	Ring seal for slip tubes 1.5mm thick, 150mm dia., Perbunan (NBR)

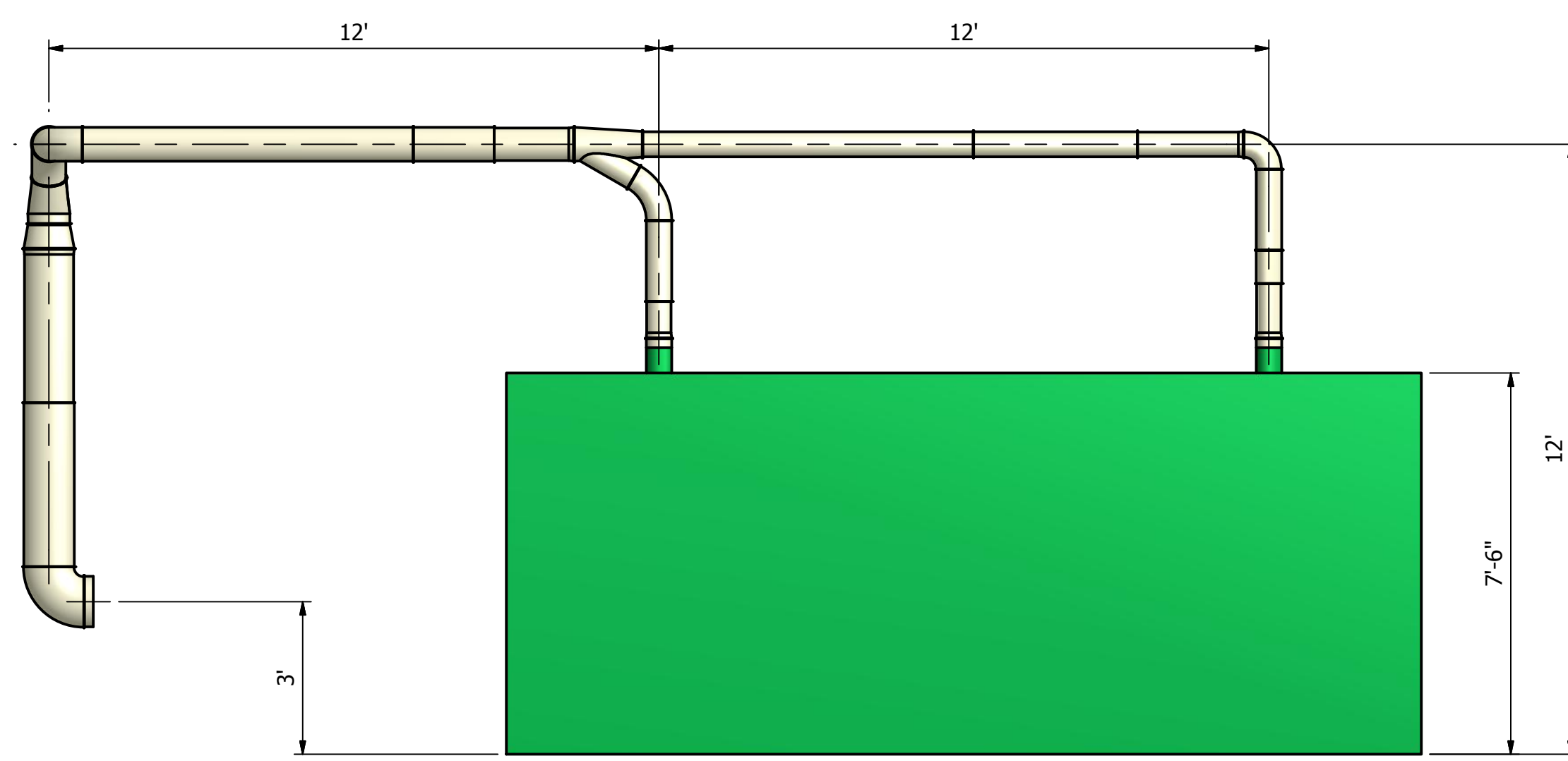
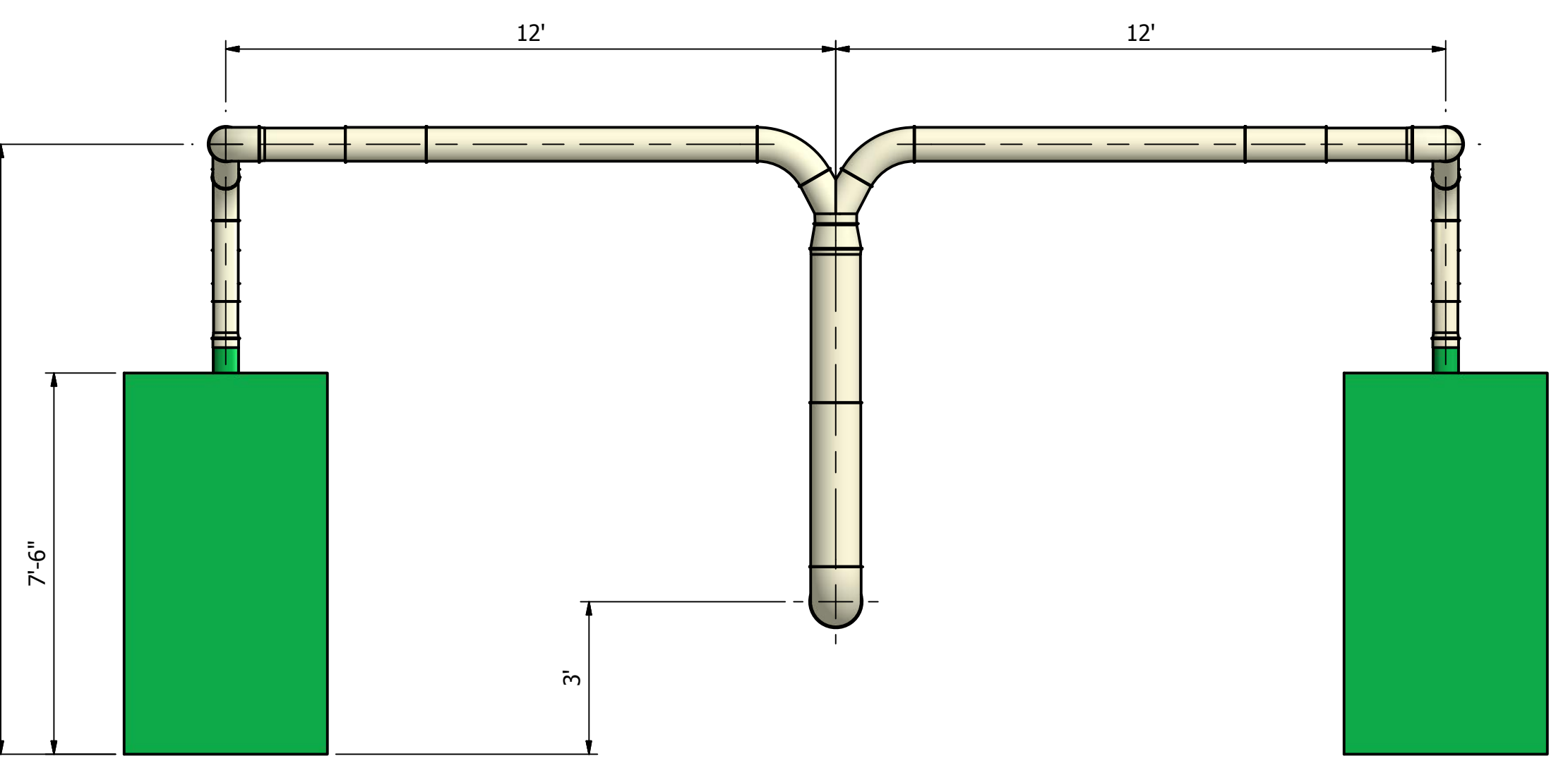

DISCLAIMER: This drawing has been generated based on verbal/written information provided to JACOB TUBING. JACOB TUBING takes no responsibility for the accuracy of the scope of material. The End-user is responsible for verifying the scope of the material.

FOR APPROVAL

Please review this drawing for accuracy; Fabrication will not proceed until this drawing is approved by the customer and returned to the JACOB TUBING Engineering department.

APPROVED AS SUBMITTED _____ (signed/dated)

APPROVED AS NOTED _____ (signed/dated)

REVISE AS NOTED & RE-SUBMIT _____ (signed/dated)

DRAWN	Author Name		
CHECKED			
QA		TITLE	
MFG		Drawing Title	
APPROVED		CUSTOMER ENTER COMPANY HERE	
		SIZE	DWG NO
		D	Q102712-L01-00
		SCALE	SCALE:
		ENTER HERE	ENTER HERE
			REV#
			SHEET 1 OF 1

This drawing is the property of Jacob Tubing LP. It is to be treated as a confidential disclosure, and is to be returned upon request. It is not to be used, in whole or in part, to the disadvantage of it's owner. All rights of design and invention are reserved. Jacob Tubing LP is not responsible for the design of systems using Jacob products.