

DO NOT SCALE

IF IN DOUBT ASK

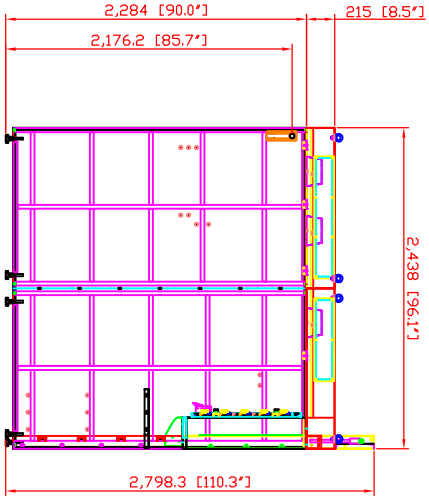

Revisions		
Rev	Description	Approved

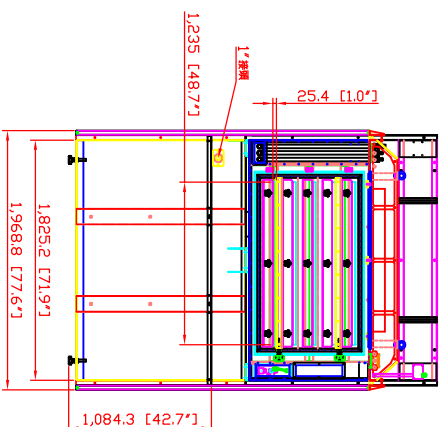
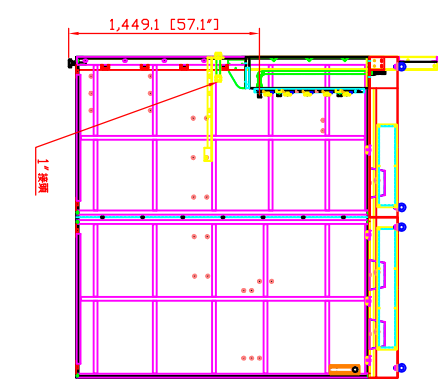
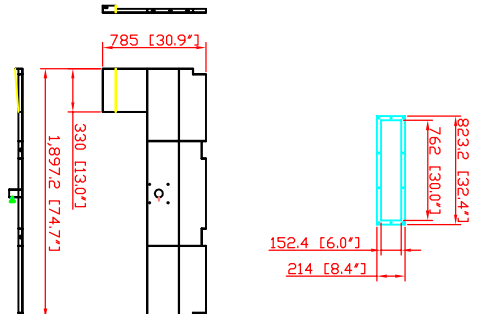
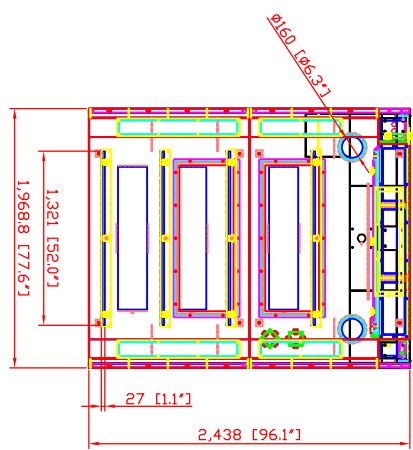
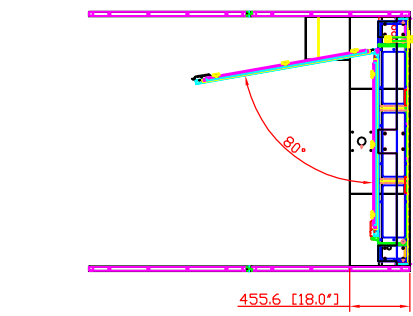

**WB-6068 WELDING BOOTH SPECIFICATIONS**

- Hood Dimensions: 68" x 96" x 6.1"
- Back Draft Dimensions: 48.7" x 35.7" x 6.9" (NOT incl. optional open shelves)
- Hood Inlet Opening: 6" x 19.9" (119.4 square inches)
- Hood Service Panel: Removable 27.6" x 27.6" service panel
- Back Draft Adjustable Inlet Slots: (5) 1" x 40.5"
- Hood Adjustable Inlet Slots: (4) 1" x 40"
- Recessed Lights: (2) Explosion Proof Lights (110V, Single Phase, 60 Hz, 20W)
- Adjustable Knobs: (2) 2 1/2" Five Star Twists
- Adjustable Level System: (8) 2 1/2" Feet (maximum adjustment 5")
- Support Structure: 1 1/2" x 4" steel stock welded
- Panel Construction: 1/2-gauge welded steel single wall with cross and up bracing
- Welding Curtain Supports: (2) adjustable welding curtain brackets
- Lifting Lugs: (4) Hood mounted lifting lugs to set and move hood or booth
- Fume Arm Ceiling Supports & Brackets: Built into the hood
- Fume Arm Cover Plates: (2) cover plates (6 bolt pattern) to match optional dia, 6" fume arm
- Powder Coated: Avant Safety Blue Standard (custom colors available)
- Seven Piece Configuration: (4) side panels, (1) back panel, (1) backdraft assembly, (1) hood/draft assembly
- Booths can be mounted back-to-back, side-to-side or both options
- Electrical Outlets: (2) 110V Outlets @ (1) Switch (additional single or three phase outlets available)
- Light Switch: For overhead lights
- Compressed Air Connection
- (3) CO2 or Gas Connection: (additional gas lines or compressed lines available)
- Double Wall Construction (welded)
- \*\*\*L-shaped Rear Shelf: 74.7"W x 1.1"H (solid with 2" hole drilled)

**OPTIONS**

- Welded Nuts: Optional locations for J-Hooks
- Welding Nuts: For wire feeder or welder bracket
- Adjustable Rear Shelf (solid, grated or cutting table)
- Corner Shelves
- Viewing Windows
- Custom Welding Brackets
- Foot Lockers
- Fixtures, Lazy Suzans
- Any option that can fit inside the booth or on the booth

**PRELIMINARY**

AVANI ENVIRONMENTAL INTL. INC. Sales Department  
 95 Cypress Drive  
 Youngsville, NC 27596  
 (919) 570-2862  
 info@avanienvironmental.com

Date	2015-03-25	Name	***	Part Number:	REVISION III	Title:	WB-6068
Drawn by:		Checked by:				Size	A
						Scale	1 = 40
						Drawing Number:	***

The drawings, AutoCAD, 3-D Models, and specifications are the property of Avani Environmental Intl. Inc. (AE) and may not be reproduced, distributed, modified, or otherwise used, except provided herein, without the express written permission of AE.