



Date: April 9, 2015

Project:

To: Michigan Prisons

Attn:

Recommended Equipment:

(3) WB-DL-6066.54 welding booth with 5HP top mount collector

Avani Environmental Intl. Inc.

95 Cypress Drive

Youngsville, NC 27596

www.avanienvironmental.com

Phone: (919) 570-2862

Fax: (919) 570-2863

Email: info@avanienvironmental.com

www.weldingbooths.com

The drawings, AutoCAD, 3-D Models, and specifications are the property of Avani Environmental Intl. Inc. (AE) and may not be reproduced, distributed, modified, or otherwise used, except provided herein, without the express written permission of AE.

DO NOT SCALE

IF IN DOUBT ASK



Revisions			
Rev	Description	Date	Approved

1. All bolts used on the booths are Imperial Hex Socket bolts.
2. Before bolts are fastened, use Loctite to seal the bolts.
The only way to loosen them is by using a blow torch; then using an imperial Allen wrench to loosen the bolts.
3. All rigid ducting used for Cartridge filter cleaning system.

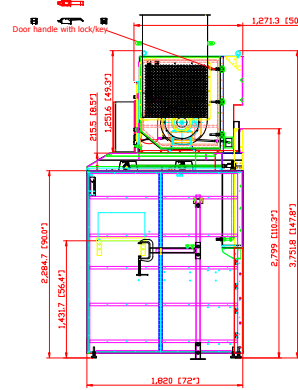
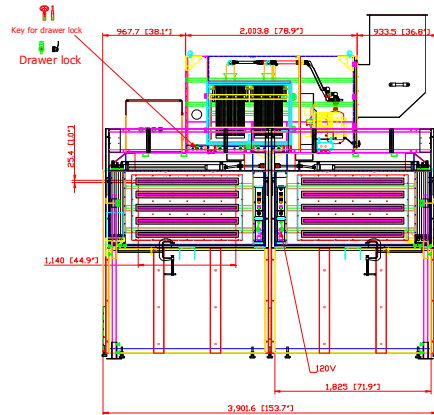
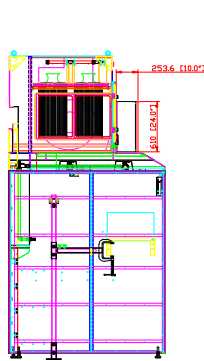
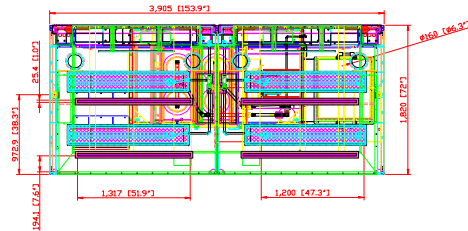
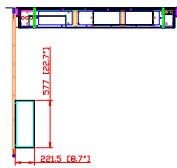
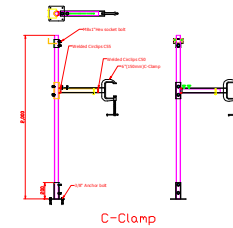
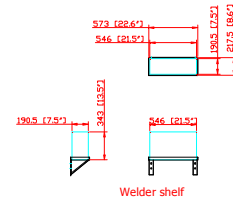

WB-6066 WELDING BOOTH SPECIFICATIONS for

- Hood Dimensions: 153.6" x 72" x 8.5"
- Back Draft Dimensions: 51.2" x 31.5" x 9"
- Back Draft Inlet Slots: (10) 1" x 44.9"
- Hood Inlet Slots: (4) 1" x 51.9"
- Recessed Lights: (4) Explosion Proof Lights (110V, Single Phase, 60 Hz, 20W)
- Adjustable Level System: 2-1/2" Feet (maximum adjustment 5")
- Support Structure: 1-1/2" x 4" steel stock welded
- Panel Construction: 12-gauge welded steel single wall with cross and up bracing
- Welding Curtain Supports: (2) adjustable welding curtain brackets
- Forklifting Lugs: total (2) 7.9"W x 3.1"H x 72"D forklifting lugs for dual booth side-by-side to set and move hood / booth / top mounted dust collector
- Fume Arm Ceiling Supports & Brackets: Built into the hood
- Fume Arm Cover Plates: (2) cover plates (6 bolt pattern) to match optional dia. 6" fume arm
- Powder Coated: Avani Safety Blue Standard (custom colors available)
- *** Nine Piece Configuration: (3) side panels, (2) back panels, (2) backdraft assembly, (2) hood/draft assembly to dual booth side-by-side. (Note: booth main set knocks down to separate pack: upper and lower part prior to shipment.)
- Booths can be mounted back-to-back, side-by-side or both options
- Electrical Outlets: (2) 110V Outlets @ (1) Switch (additional single or three phase outlets available)
- Light Switch: For overhead lights
- Compressed Air Connection
- CO2 or Gas Connection: (additional gas lines or compressed lines available)
- Double Wall Construction (welded)
- ***Welder bracket/shelf

OPTIONS

- Welded Nuts: Optional locations for J-Hooks
- Welding Nuts: For wire feeder or welder bracket
- Adjustable Rear Shelf (solid, grated or cutting table)
- Corner Shelves
- Viewing Windows
- Custom Welding Brackets
- Foot Lockers
- Fixtures, Lazy Suzans
- Any option that can fit inside the booth or on the booth
- Silencer Outlet
- HEPA Module

TMC-5-4 dust collector on booth top SPECIFICATIONS for

Motor:	5 HP NEMA
Electric Spec:	230/460V / 60Hz / 3Ph (wired at 460V) can be rewired in ONE voltage: either: 230V / 60Hz / 3Ph / 14.5A (wired at 230V) or 460V / 60Hz / 3Ph / 7.3A (wired at 460V)
Airflow:	2340 ft3/min 3973.32 m3/hr
Filteration Stages:	1st - aluminum mesh x (2) pcs Spec: 540 x 440 x 22 mm (21.3" x 17.3" x 0.87") 2nd - cartridge filter x (4) pcs Spec: Dia. 380 x 660mmL (dia. 15" x 26") Filtering area: 15M2 x 4 = 60M2 (645.6 FT2) Material: Polyester Spun bond with TEFLON treatment & coating
No. of Valves:	2
Compressed Air Requirement:	90 PSI
Compressed Air Reservoir:	2.63 gallon
Construction:	14 gauge steel
Max. Operating Temp.:	120°C
Paint Color:	Blue
Sound Level dBA	average decibel rating: 78 dBA (measured @ 1m/3.3ft away from the unit), average decibel rating: 77 dBA (measured @ 3m/9.8ft away from the unit).
Accessories:	HEPA: (1) 30.1" x 25.4" x 2" per collector
	**gauge hole pre-drilled.

PRELIMINARY

AVANI ENVIRONMENTAL INTL. INC. Sales Department
 95 Cypress Drive (919) 570-2862
 Youngsville, NC 27596 info@avanienvironmental.com

Date	2015-04-08	Name	***	Part Number:	
Drawn by:				REVISION E	Title: WB-6066 (2sets side-by-side) with TMC-5-4
Checked by:					
The drawings, AutoCAD, 3-D Models, and specifications are the property of Avani Environmental Intl. Inc. (AE) and may not be reproduced, distributed, modified, or otherwise used, except provided herein, without the express written permission of AE.				Size	Scale
				A	1 = 45

Title: WB-6066 (2sets side-by-side) with TMC-5-4	
Size	Scale
A	1 = 45
Drawing Number: Michigan Dept. of Prisons Page 1 of 1	

In regards to the M8 hex socket bolt, please kindly refer to the details below, which were discussed with Ed before. Please review and share your comments and feedback.

Use Imperial Hex Socket bolts.



Before bolts are fastened, use Loctite to seal the bolts. The only way to loosen them is by using a blow torch; then using an imperial Allen wrench.



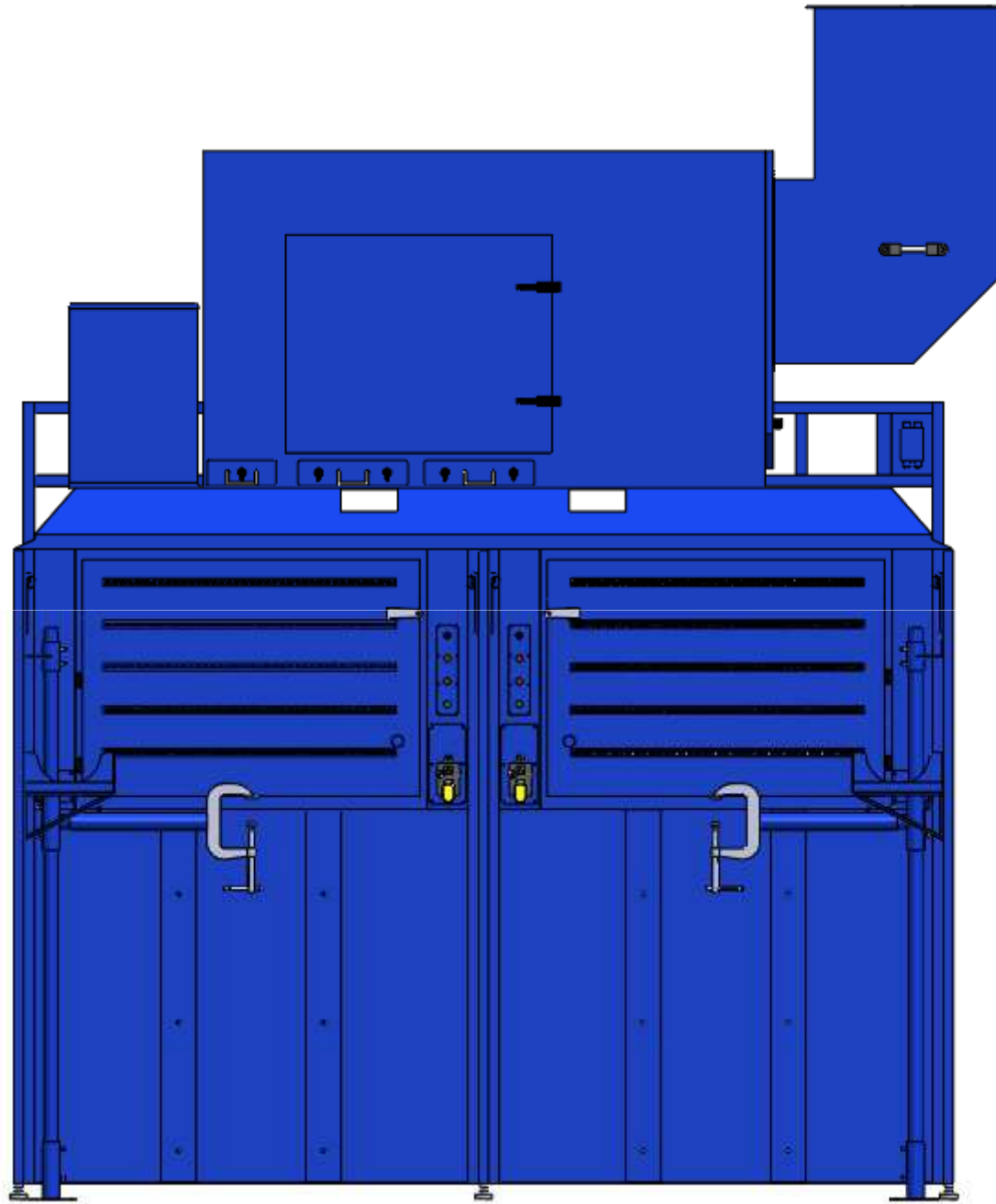



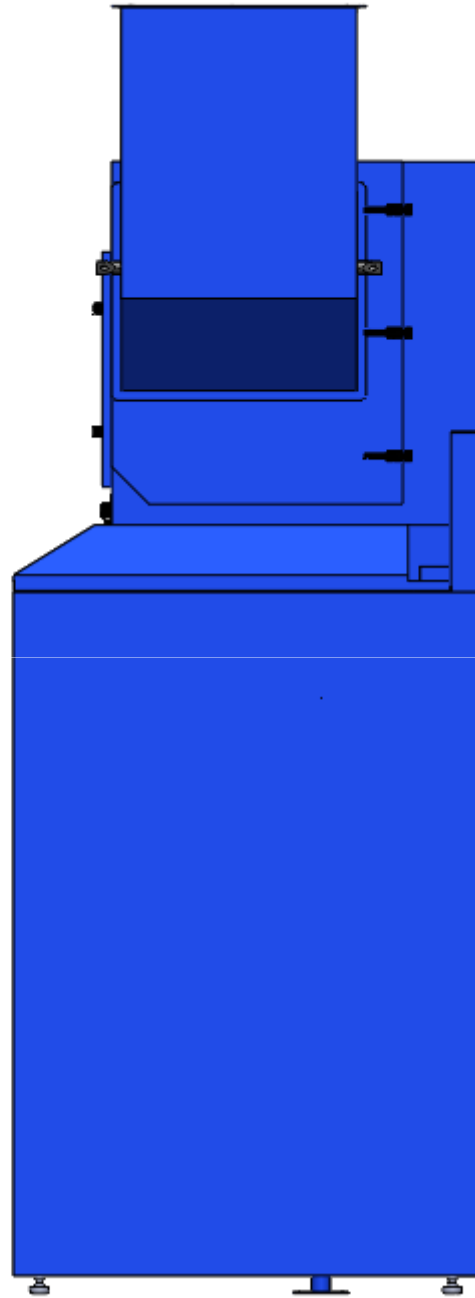

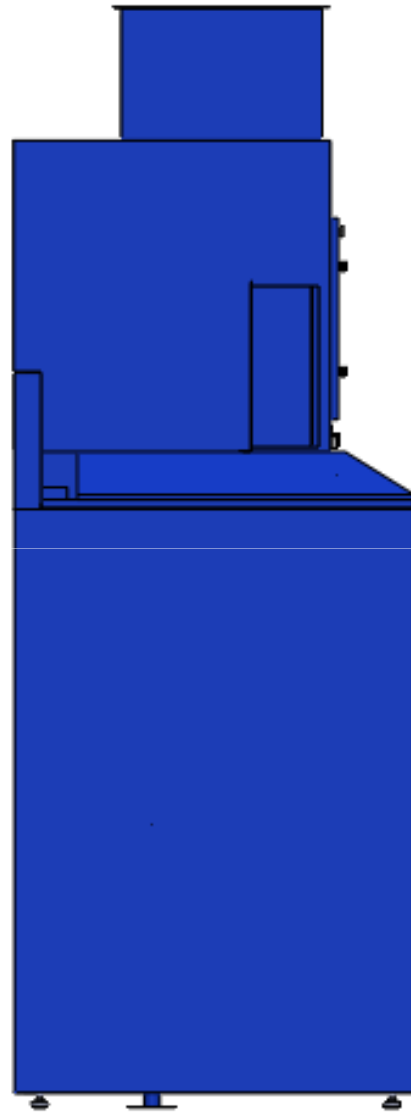

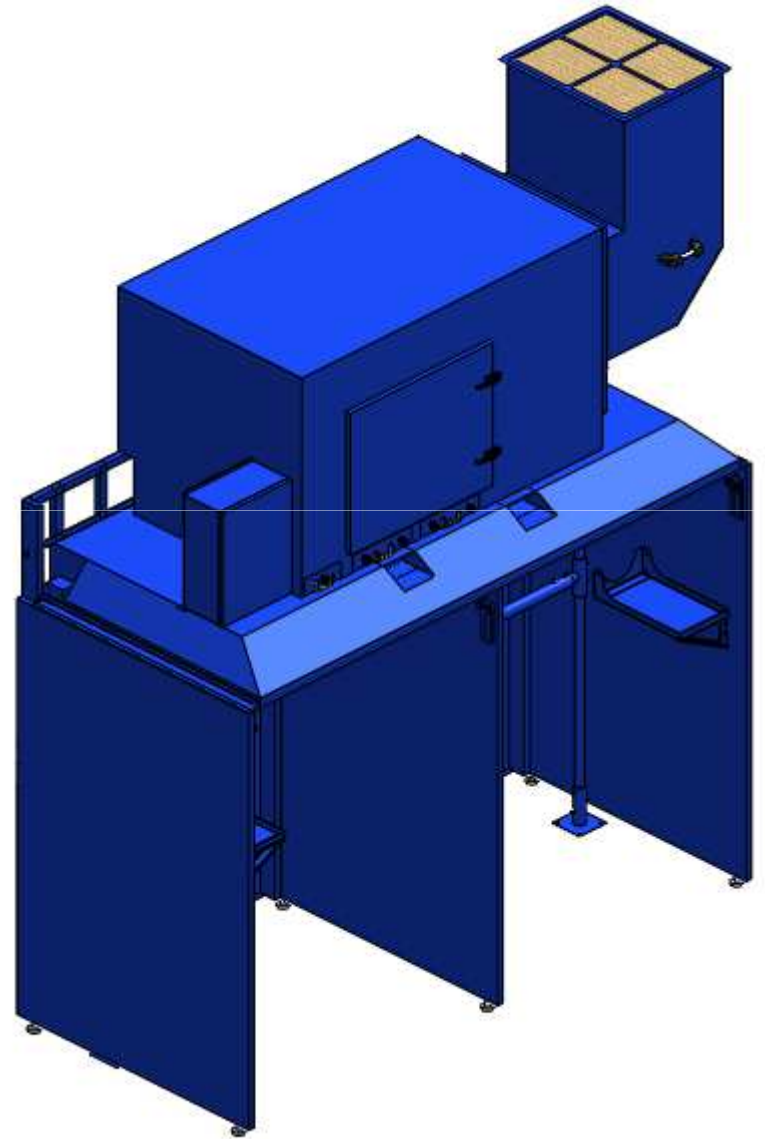
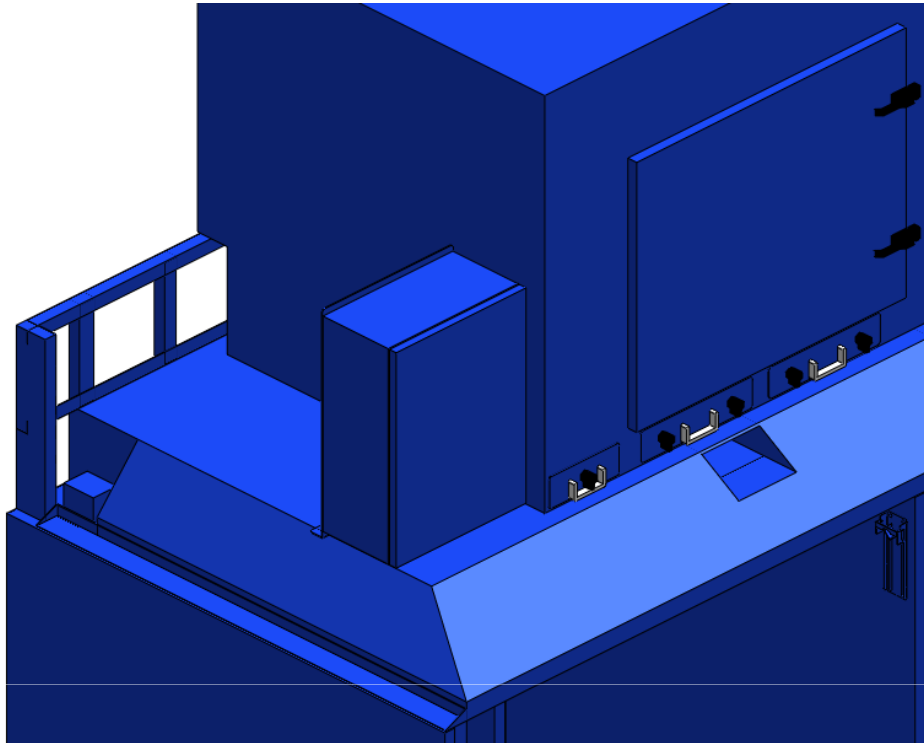

C clamp

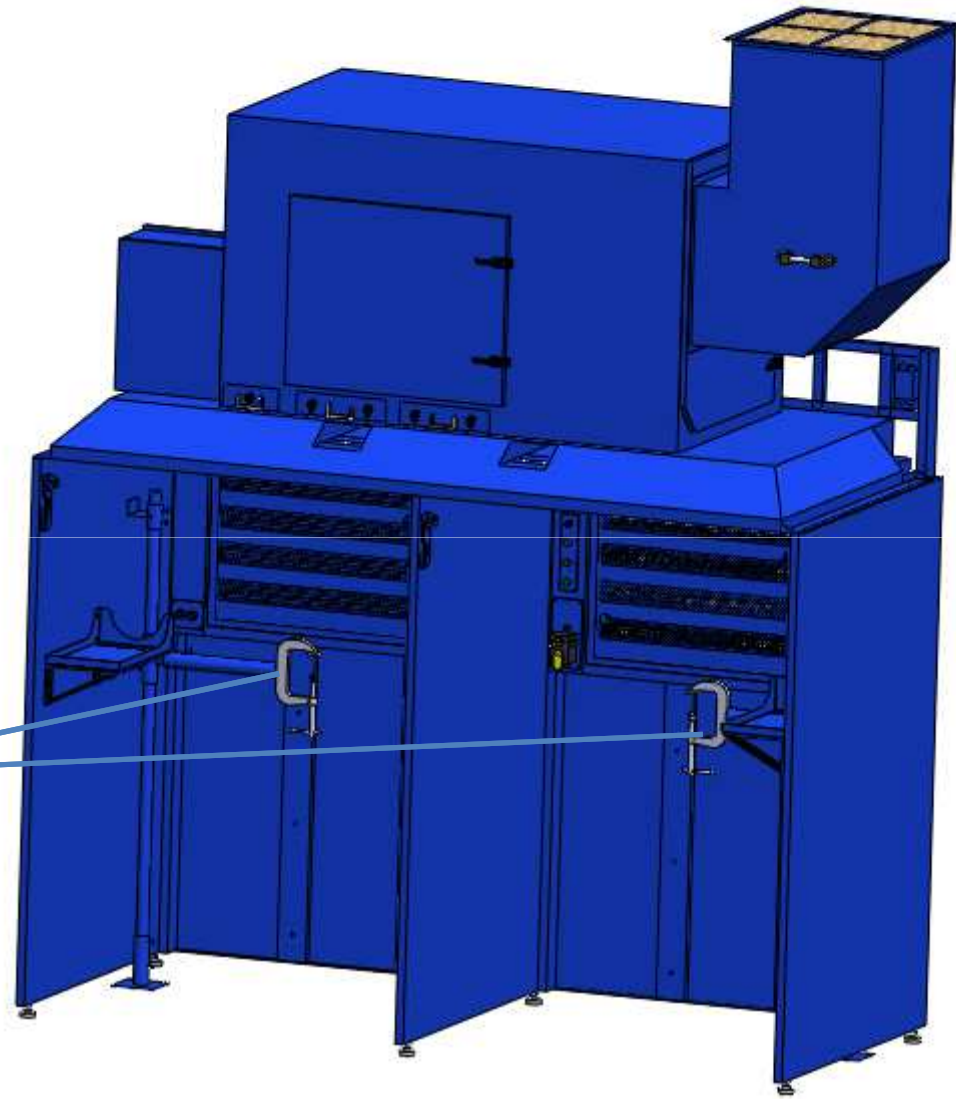

CO2 bracket

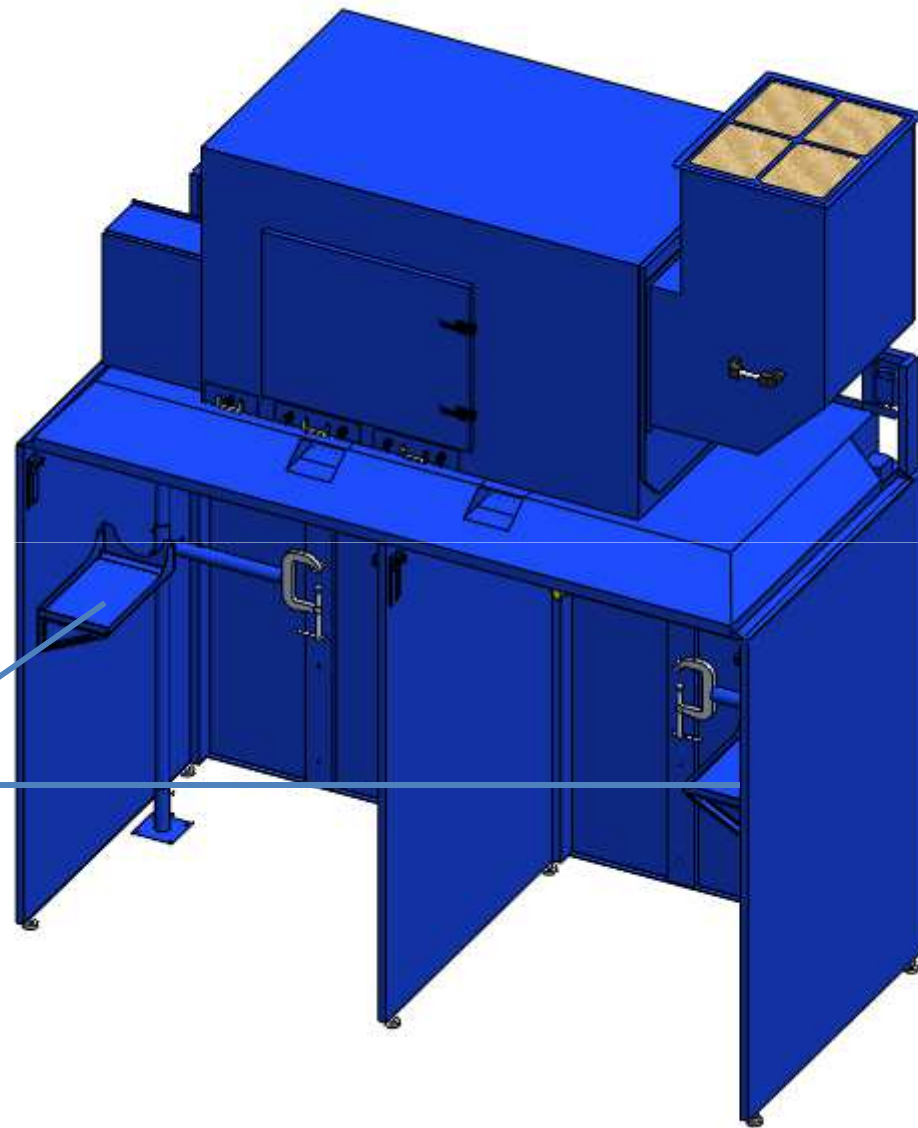

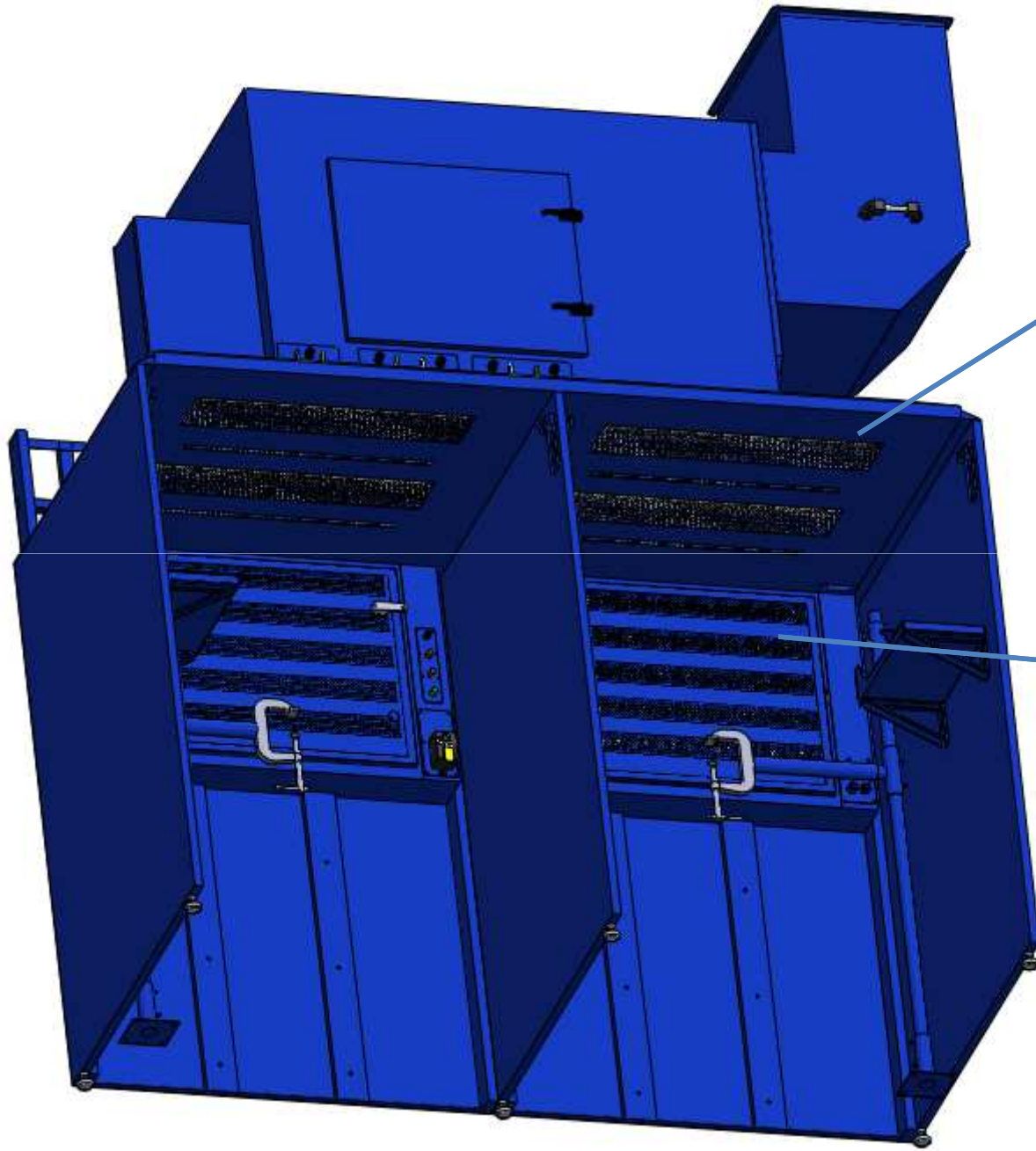

(4) Working lights with net

Backdraft with net

Curtain

