

North Hardin School
po# 4682

WB-1035 WELDING BOOTH SPECIFICATIONS

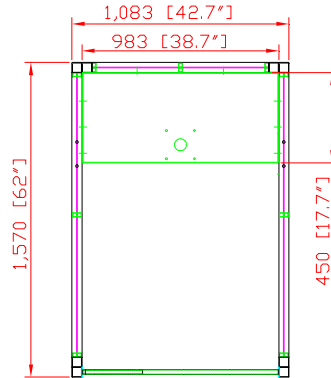

- Adjustable Level System: (4) dia. 2.36" Feet
- Panel Construction: 11-gauge welded steel
- Welding Curtain Supports: (1) set welding curtain bar
- Powder Coated: Avani Safety Blue Standard (custom colors available)
- Three Piece Configuration: (2) side panels, (1) back panel.
- Booths can be mounted back-to-back, side-by-side or both options
- ***Unadjustable Fixed Rear Shelf: 38.7"W x 20"D x 1.1"H (solid with 2" hole drilled)

OPTIONS

- Welded Nuts: Optional locations for J-Hooks
- Welding Nuts: For wire feeder or welder bracket

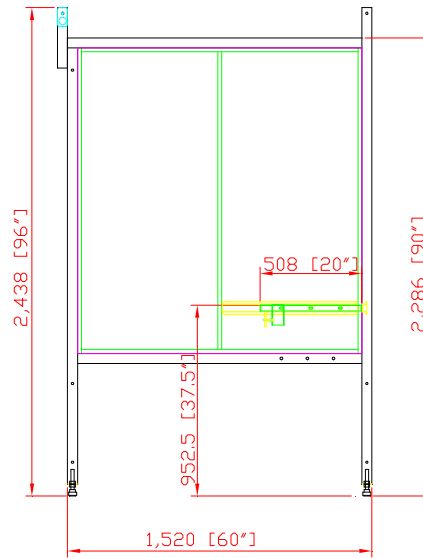
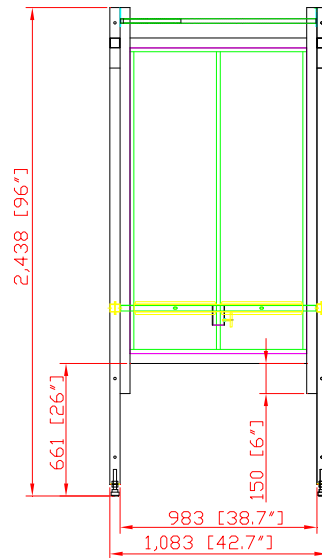

AVANI ENVIRONMENTAL INTL. INC. Sales Department
95 Cypress Drive
Youngsville, NC 27596
(919) 570-2862
info@avanienvironmental.com

Date	Name	Part Number:	Title:
2012-06-07	***	***	Booth WB-1035
Drawn by:	Checked by:		

The drawings, AutoCAD, 3-D Models, and specifications are the property of Avani Environmental Intl. Inc. (AE) and may not be reproduced, distributed, modified, or otherwise used, except provided herein, without the express written permission of AE.

Size: **A** Scale: 1 = 25 Drawing Number: WB-3x5S

DO NOT SCALE

IF IN DOUBT ASK

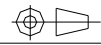

Revisions			
Rev	Description	Date	Approved

(6) WB-1035 side-by-side

North Hardin School

po# 4682

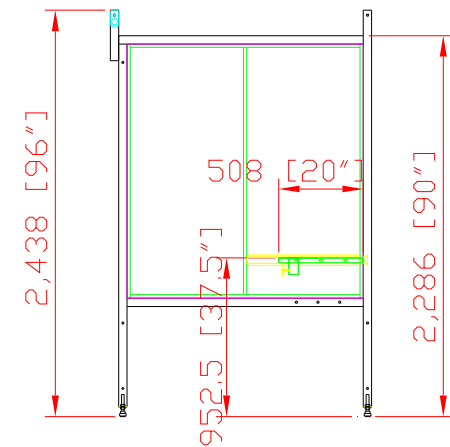
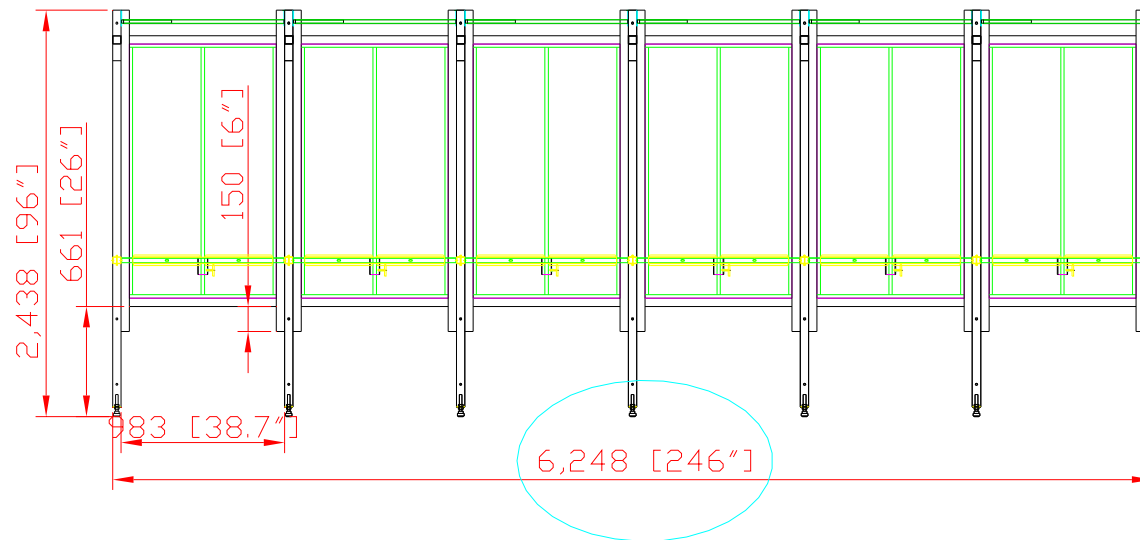
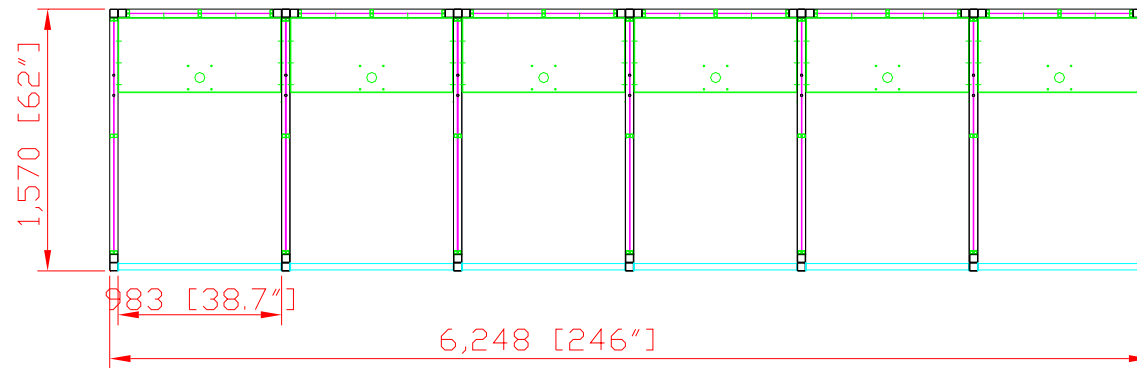

PO# 4682 item ordered:
- WB-1035 (6)

AVANI ENVIRONMENTAL INTL. INC. Sales Department 95 Cypress Drive (919) 570-2862 Youngsville, NC 27596 info@avanienvironmental.com	Date: 2012-06-07 Name: ***	Part Number: WB-1035 (6)	Title: North Hardin School	
	Drawn by: Checked by:	The drawings, AutoCAD, 3-D Models, and specifications are the property of Avani Environmental Intl. Inc. (AE) and may not be reproduced, distributed, modified, or otherwise used, except provided herein, without the express written permission of AE.	Size: A	Scale: 1 = 35
	Drawing Number: ***			