

Collector indoors/up against the wall

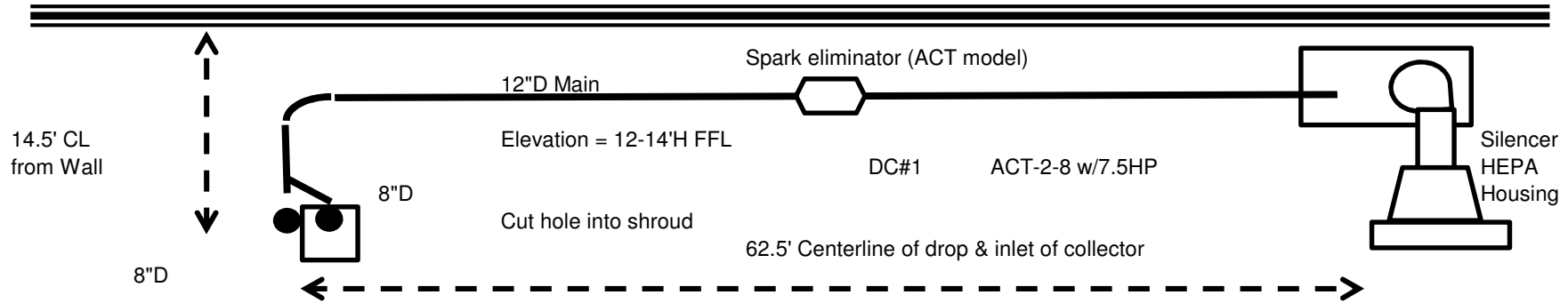

Remove fan or add adapter for 8"D connection

Cut-off saw #1 w/existing shroud; add drop into the top or rear of existing enclosure.

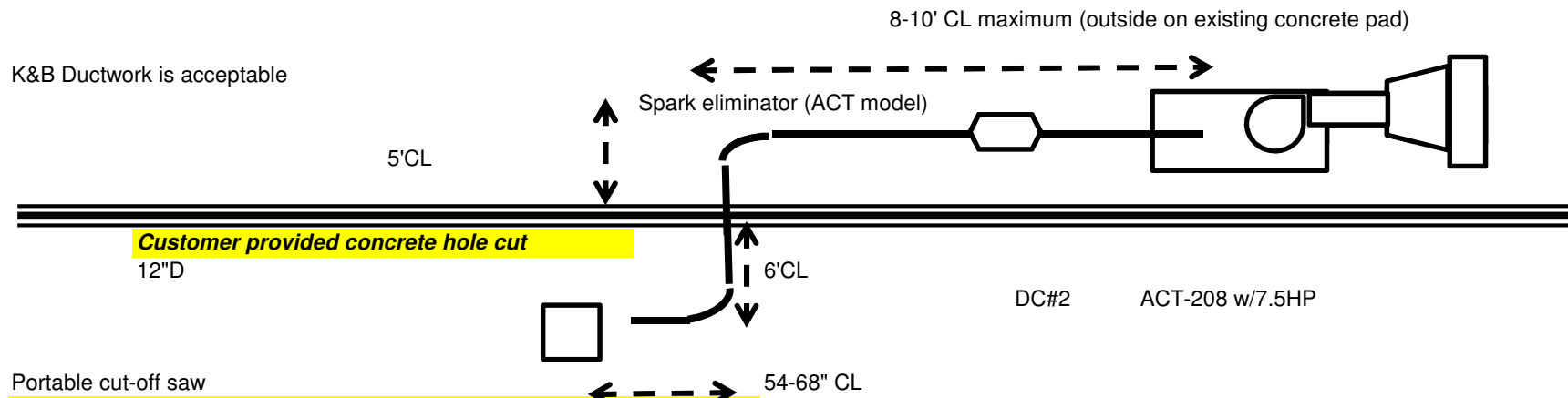

Portable cut-off saw

Customer to aid in fabrication of shroud to fit over saw - bring galvanized flat stock sheets or pick-up local

Customer will weld or aid us in fabrication of enclosure

Plan on drop height or duct height of 12'+ H FFL to 14'H FFL

Contact on site will be:
Mr. Bobby Fink
bfink@midwesthose.com
Office: 405.670.6718

Drop terminate into flexible hose; 10'L of 12"D

Provide collar for enclosure 12"D angle flange

Ceiling height appears to be 25' +/- - Call Bobby to arrange for their lift rental, etc.

