

SPECIFICATIONS

DIMENSIONS:

11 7/8" H X 23 1/2" W X 8 1/8" D

RECOMMENDED MAX AIR FLOW 500 CFM

.22" WG RESISTANCE AT 250FT/MIN

16 GA. BLACK POWDER COATED CASE

6 PANELS V-BANK CONFIG

PANELS 26 GA BLACK POWDER COATED

WEIGHTS:

EMPTY: 20 LBS

CARBON: APPROX. 15 LBS

50/50 BLEND: APPROX. 22 LBS

POTASSIUM: APPROX. 29 LBS

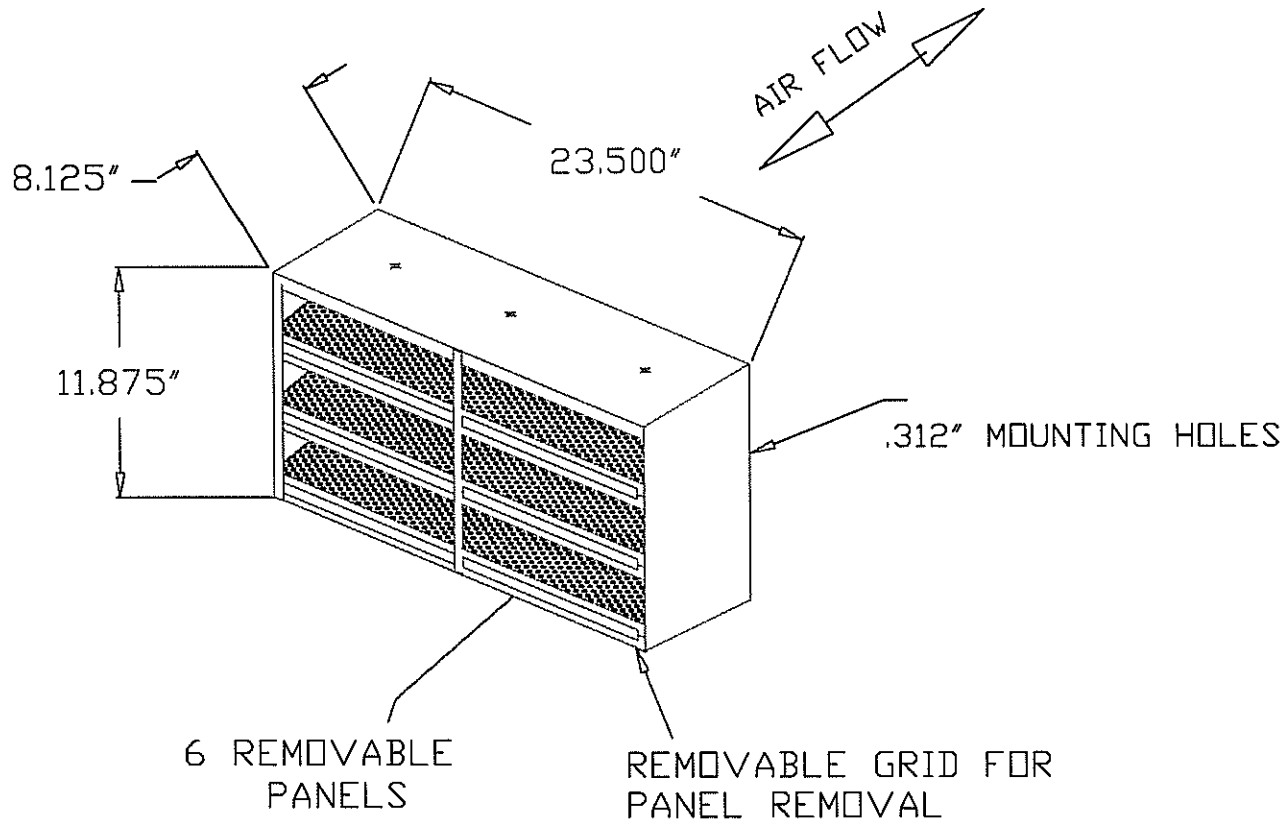

TITLE:

RSE 1000H

SCALE:

DWG NO.

DRAWN:

APPROVED:

DATE:

09/19/03

CHECKED:

CUSTOMER:

RSE
INCORPORATED

51529 Birch St.
New Baltimore, MI 48047
(586) 725-0192