

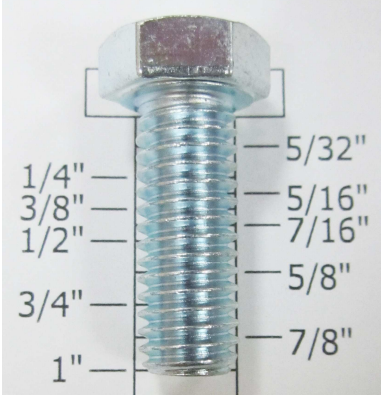

✚ Installations for the unit for SDC-15-16.



✚ Installations for the unit for SDC-15-16.

- Take out the base of air tank.
- Secure the base of air tank to the unit with:

Hardware (Screw attached to inside)				
Part name	Description	Photo	Q'ty	Grainger Model #
Hex Screw	3/8" x 1"		4	1YU43
Flat Washer	3/8" x OD23 x 2T		4	*1JY33

(* Hardware item at similar spec available locally.

✚ Installations for the unit for SDC-15-16.



The base of air tank



Complete Assembled.

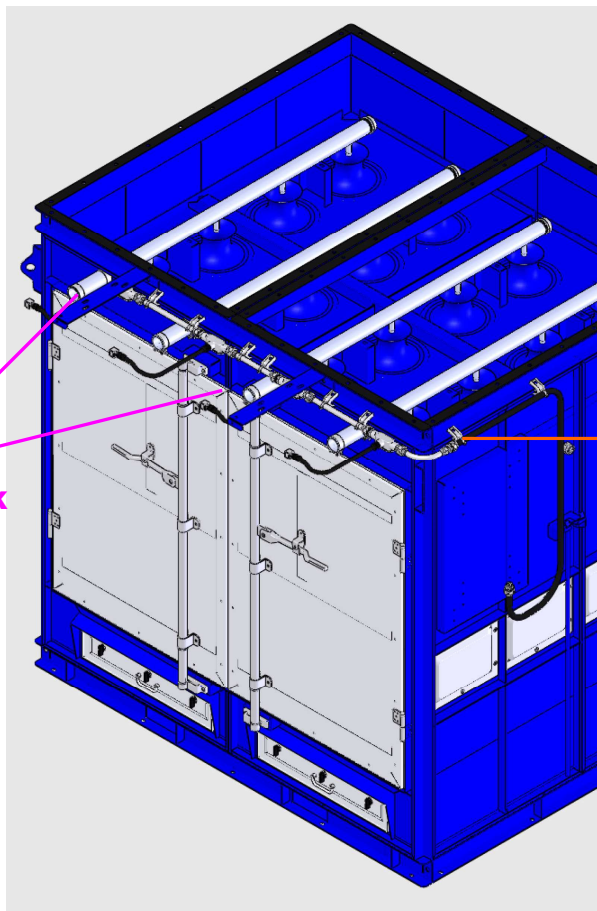
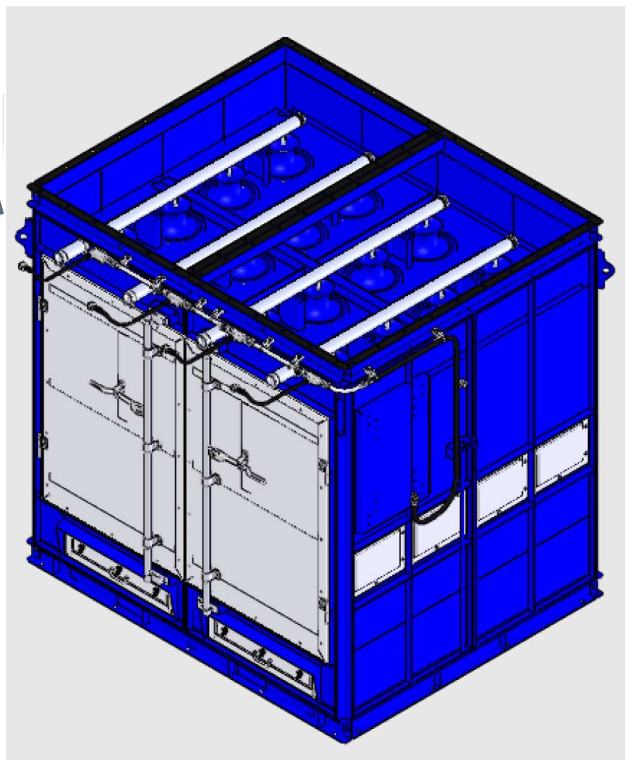

The base of air tank

SDC-15-16

✚ Installations for the unit for SDC-15-16.



Have not locked, is putting air tank and adjusting the position.

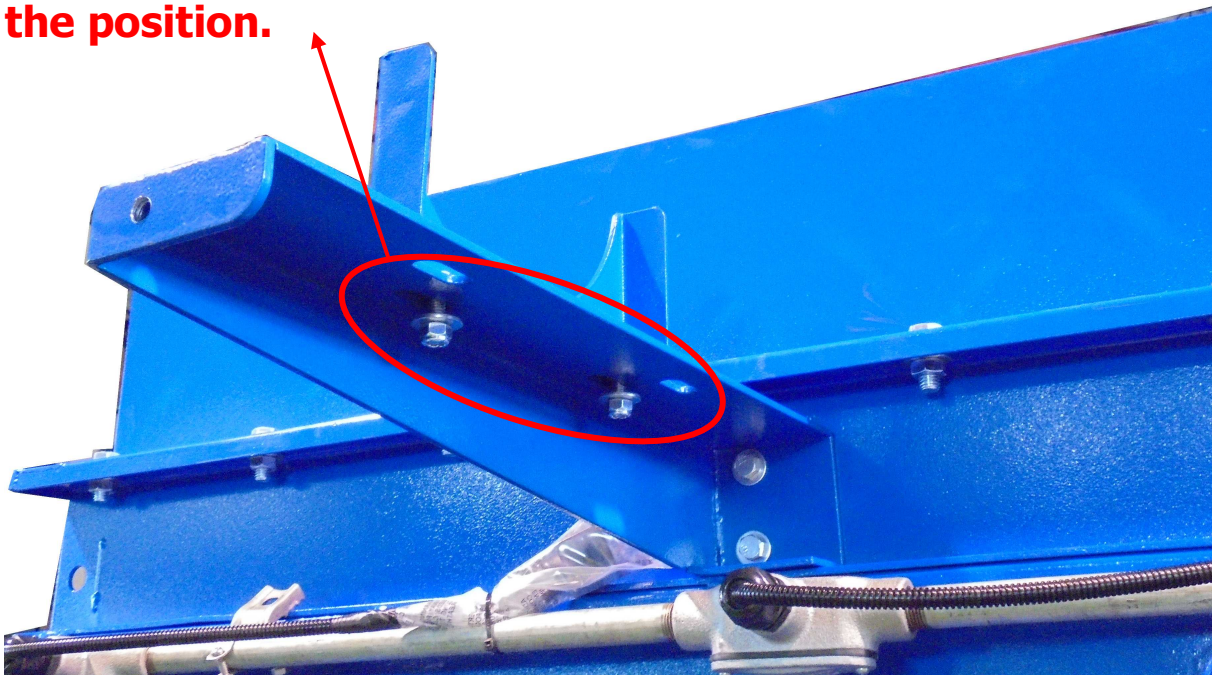

✚ Installations for the unit for SDC-15-16.

- Take out the number: **AT**.
- Place **AT** on the base of air tank.

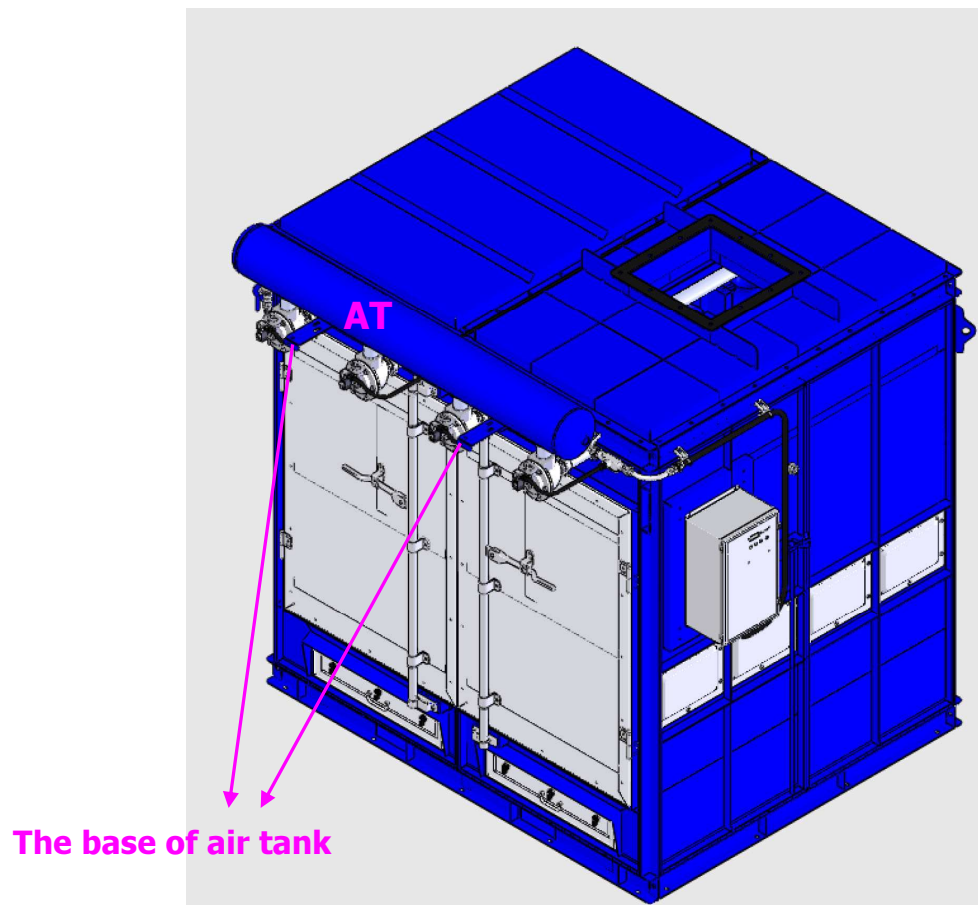
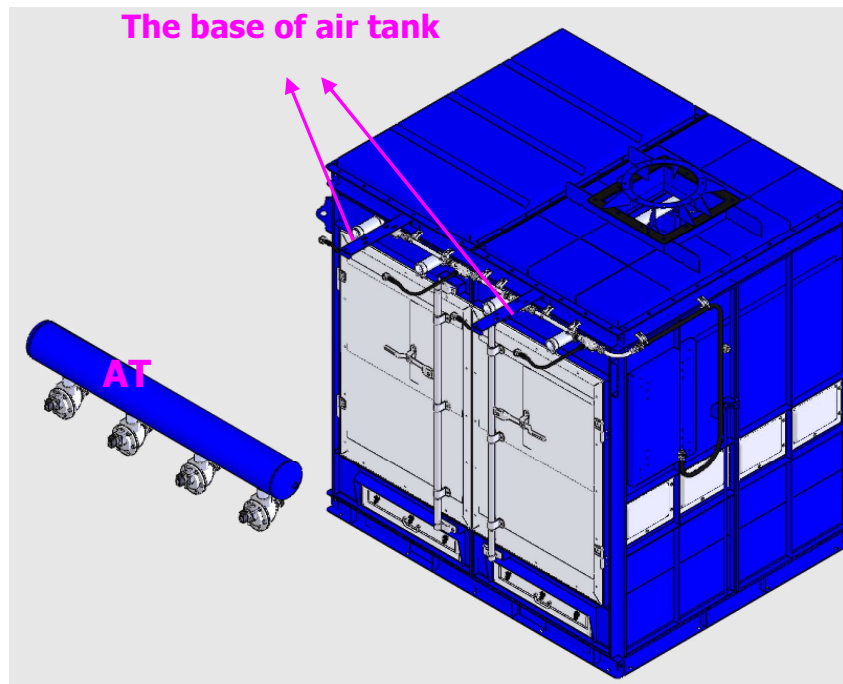

✚ Installations for the unit for SDC-15-16.

- Insert the connector into the coupling.
- Fasten the clamp.

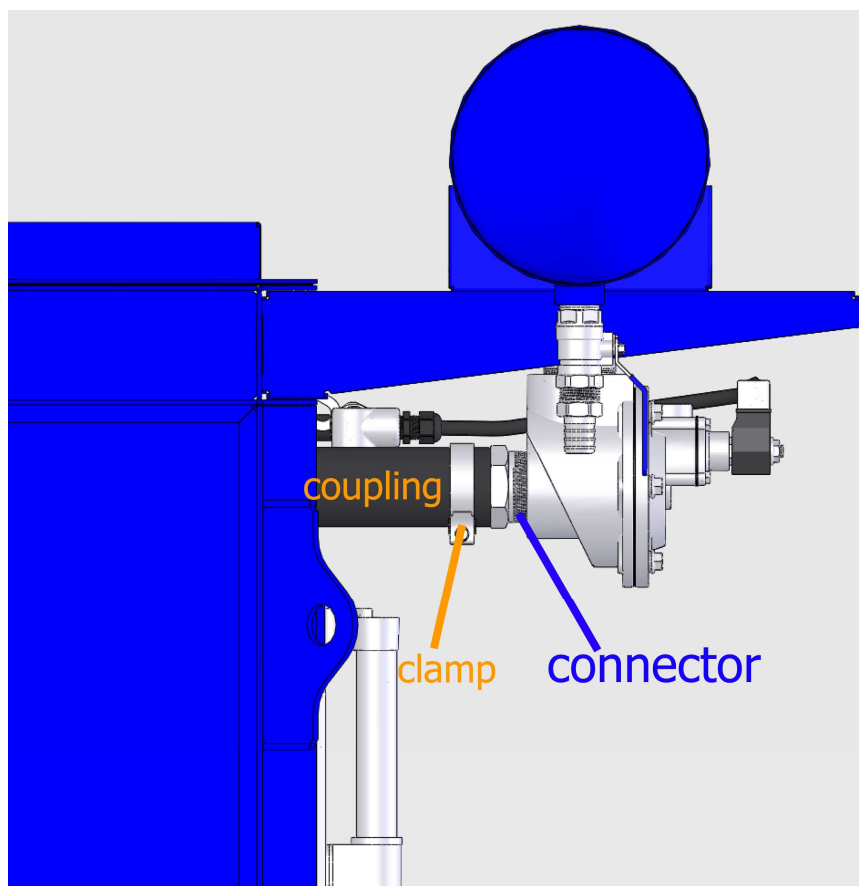
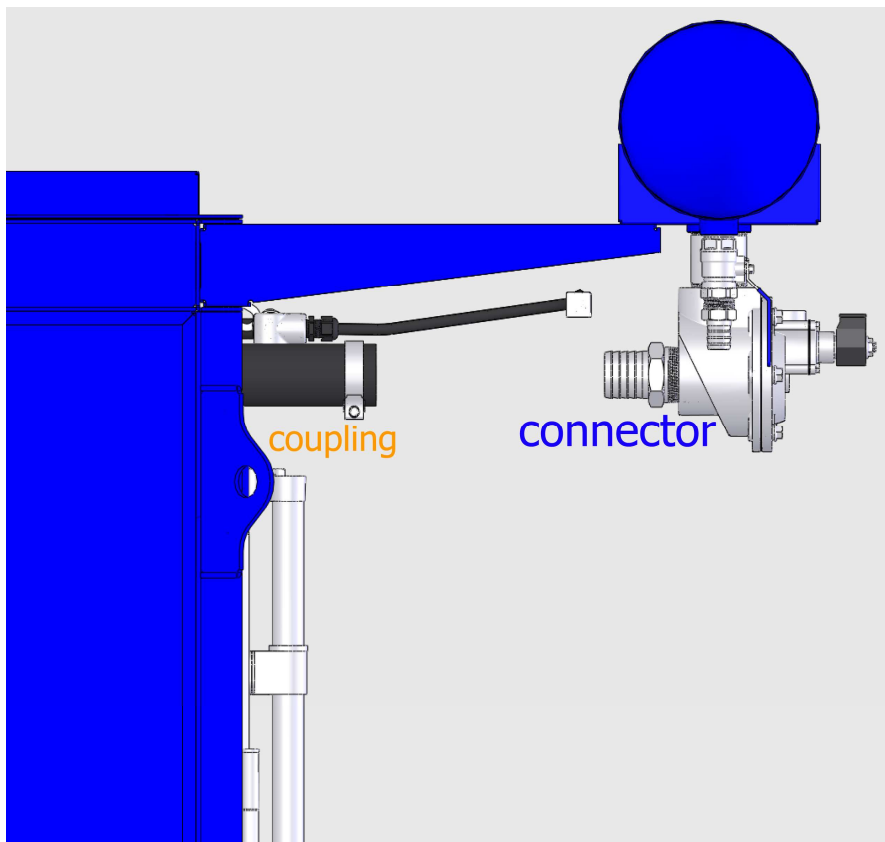

✚ **Installations for the unit for SDC-15-16.**

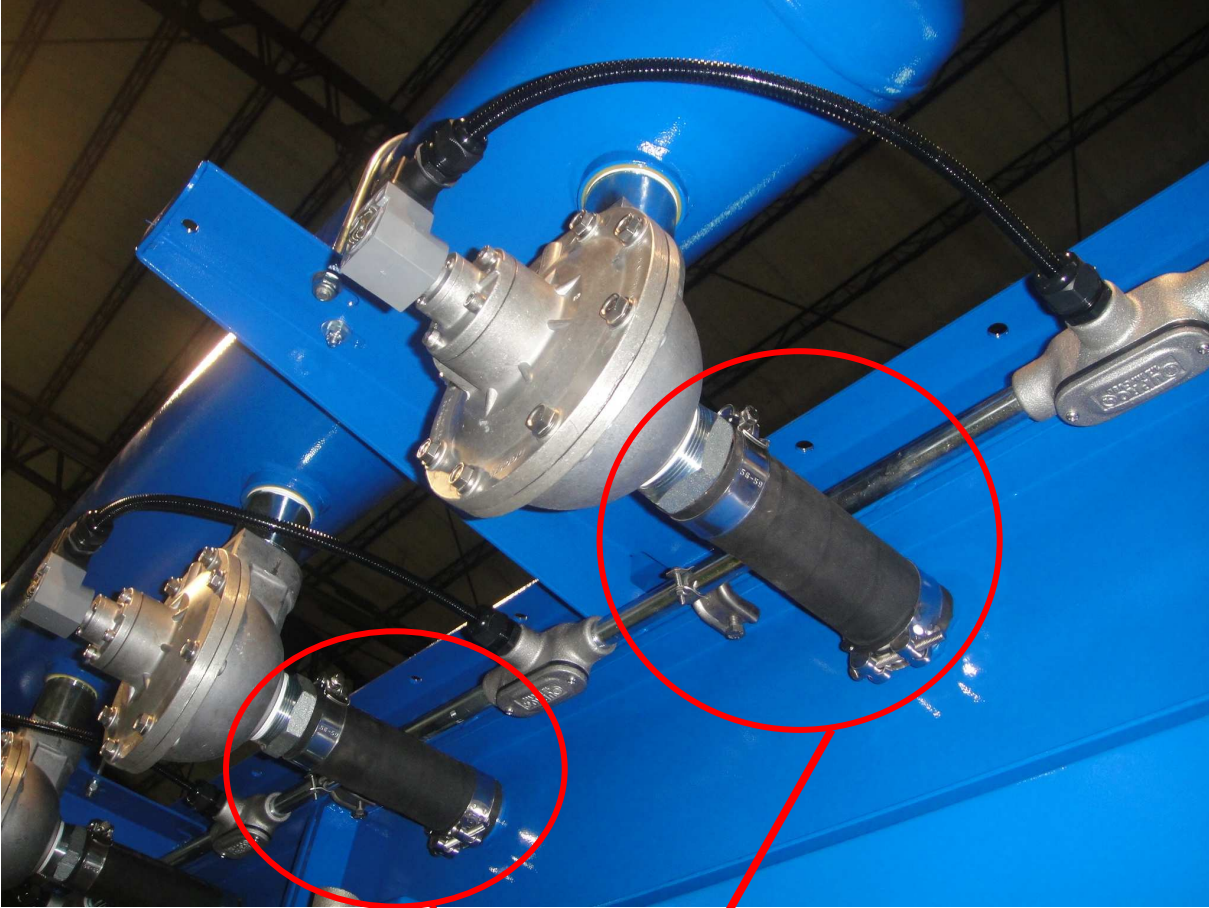

Clamp
(Clamp attached to inside)

Installations for the unit for SDC-15-16.

- Fasten the coin.

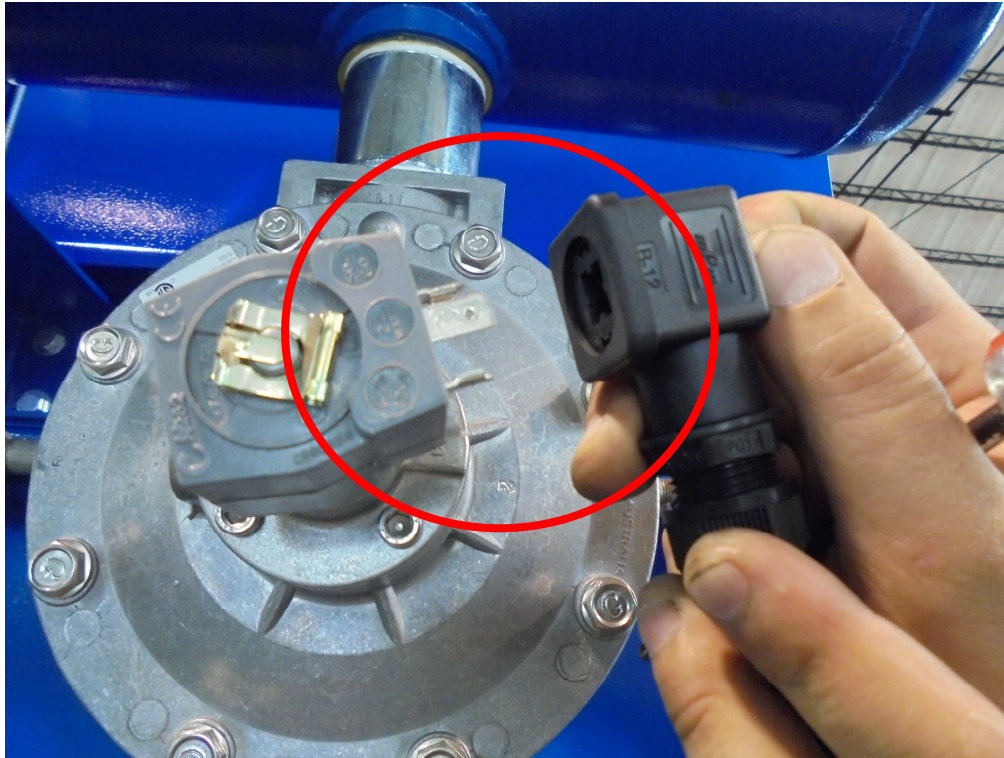

- Fasten the Philips Head Screw with a screwdriver.

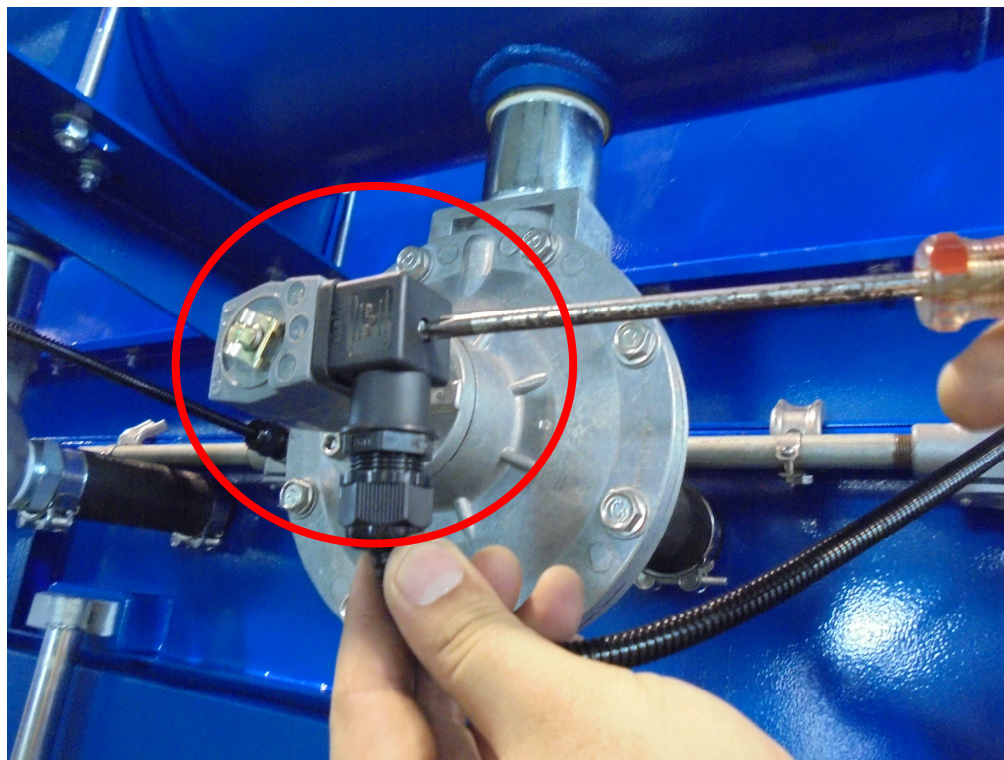

✚ Installations for the unit for SDC-15-16.

- Take out **U-Bolts**.
- Use **U-Bolts** to secure the air tank:



Release the screw which already on the U-Bolts, as red frame shown.

U-bolts

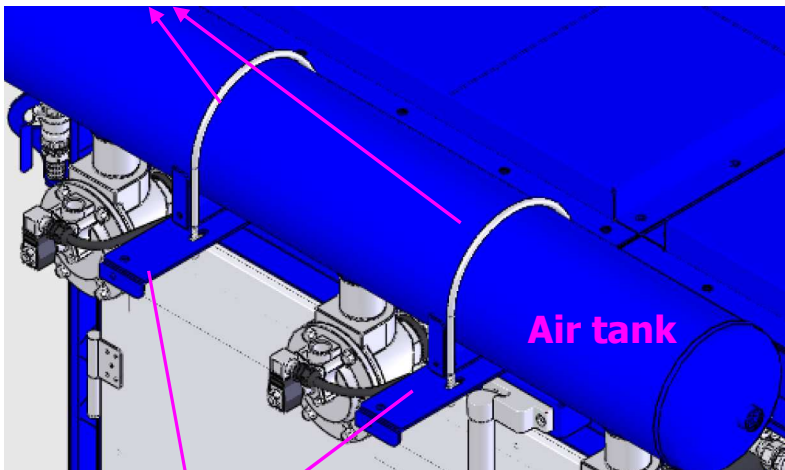

The base of air tank



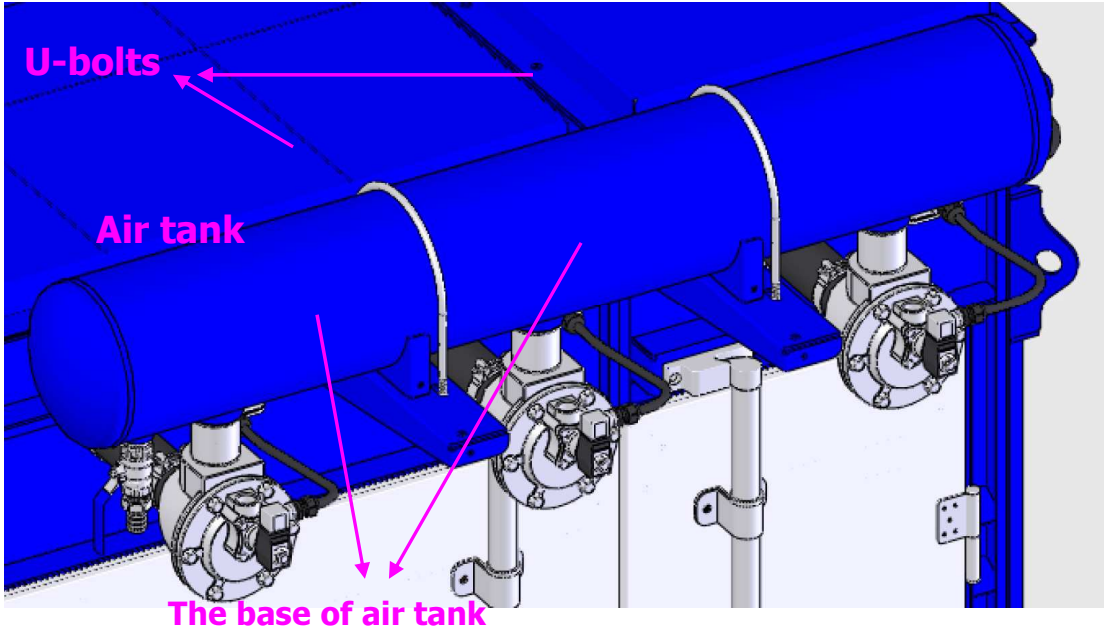

✚ Installations for the unit for SDC-15-16.

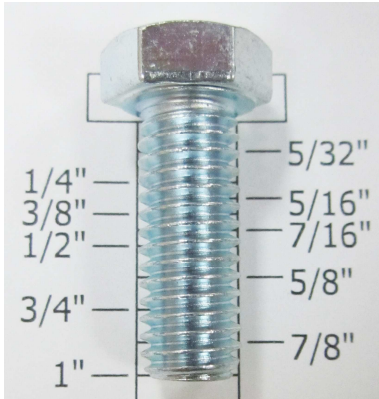
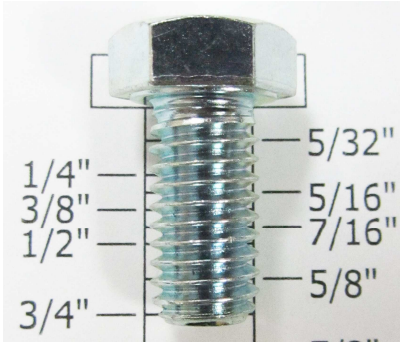

✚ Installations for the unit for SDC-15-16.

- Take out the number: **AC**.
- Fasten **AC** to the base of air tank with:

Hardware (Screw attached to inside)				
Part name	Description	Photo	Q'ty	Grainger Model #
Hex Screw	3/8" x 1"		2	1YU43
Hex Screw	3/8" x 3/4"		2	1YU42
Flat Washer	3/8" x OD23 x 2T		4	*1JY33

(*) Hardware item at similar spec available locally.

Installations for the unit for SDC-15-16.

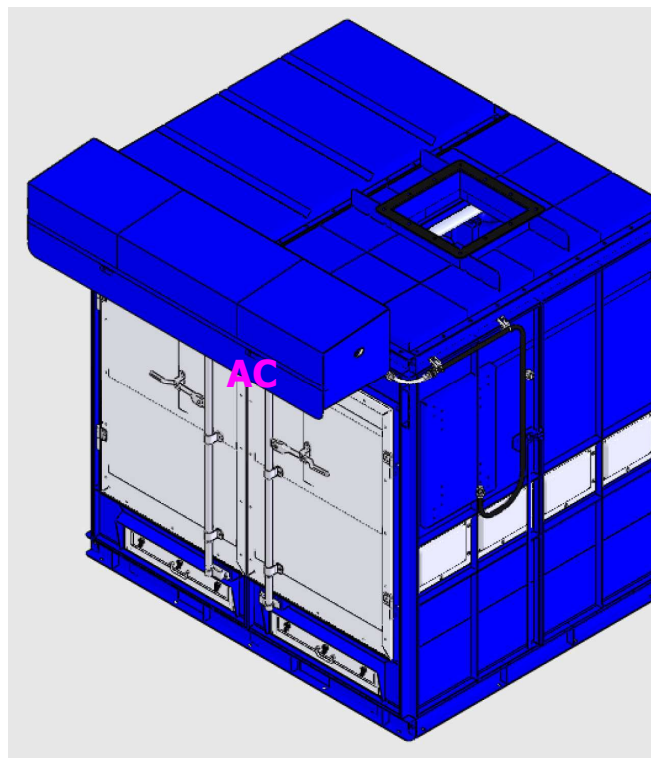
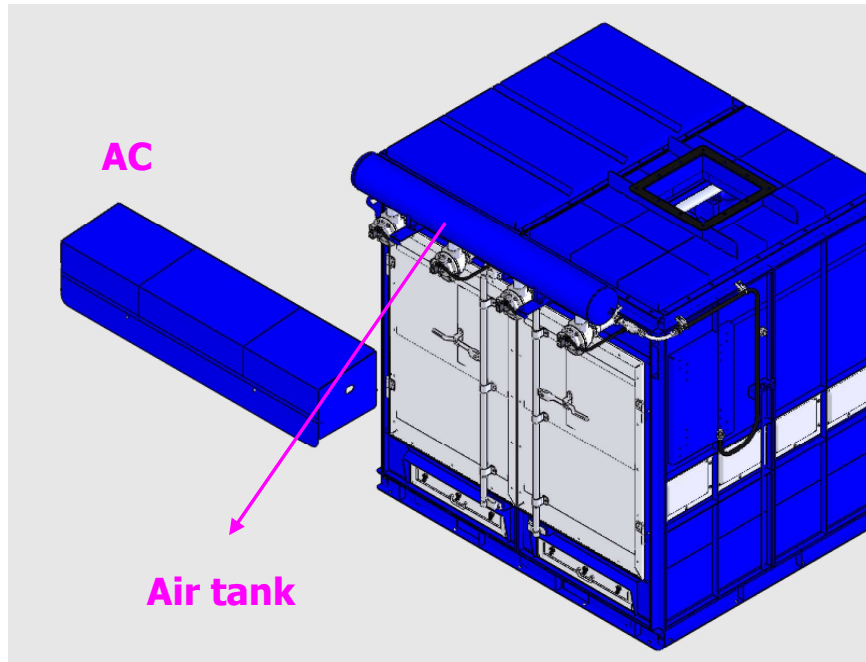

Installations for the unit for SDC-15-16.

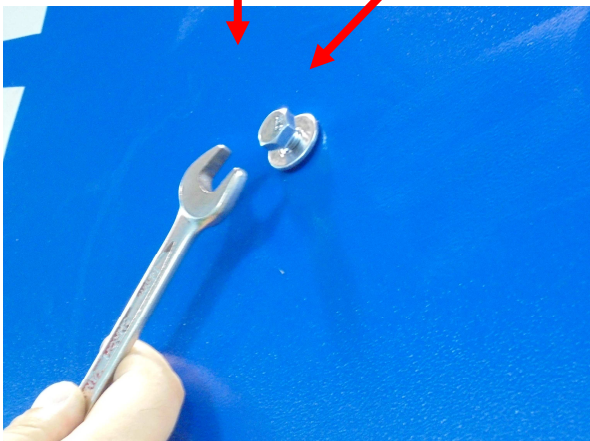

Outside

Inside

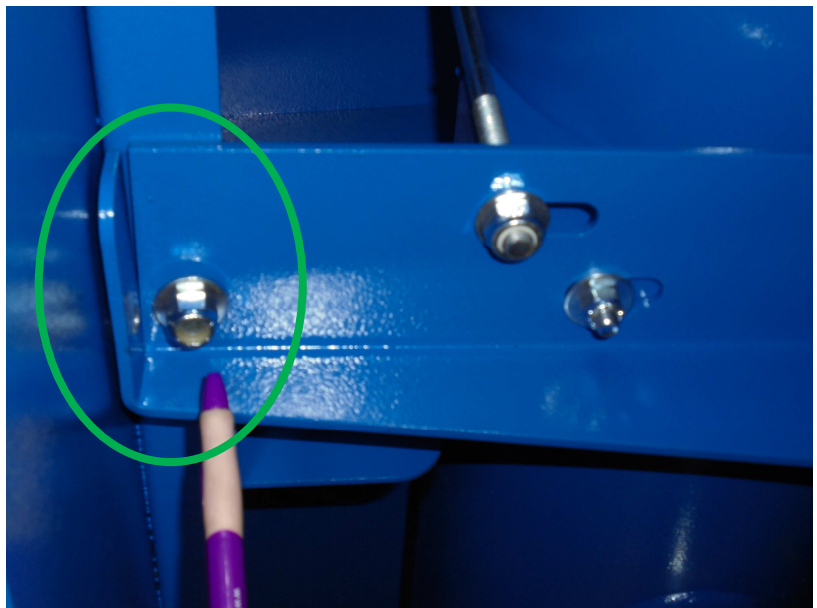

✚ Installations for the unit for SDC-15-16.

- Take out the **Nipple**.
- Fasten the **Nipple** to the air tank.

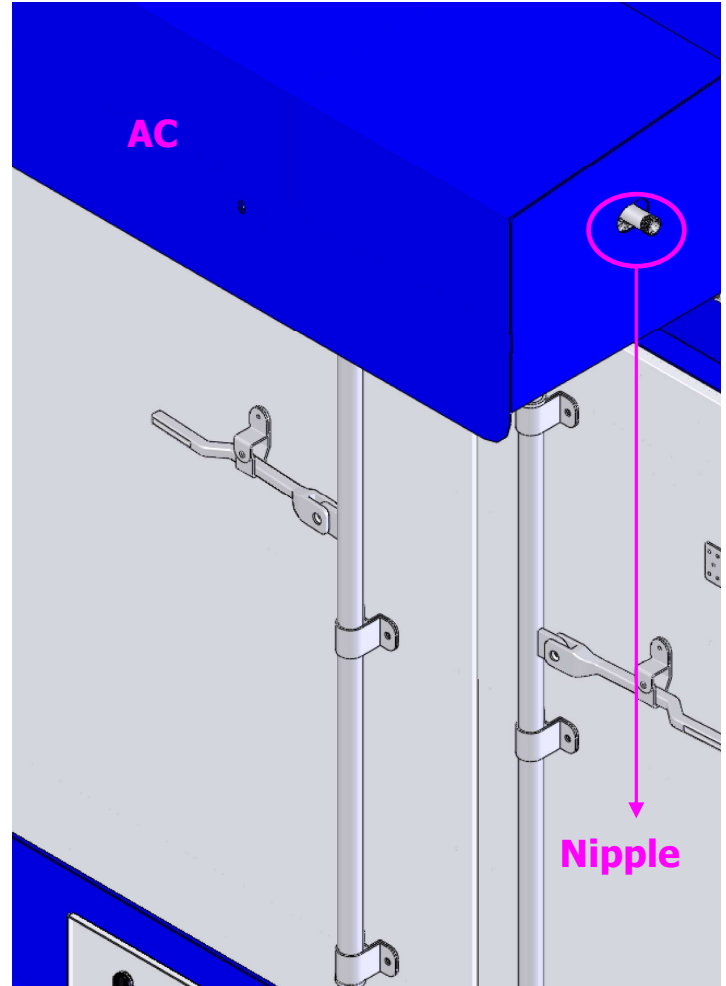
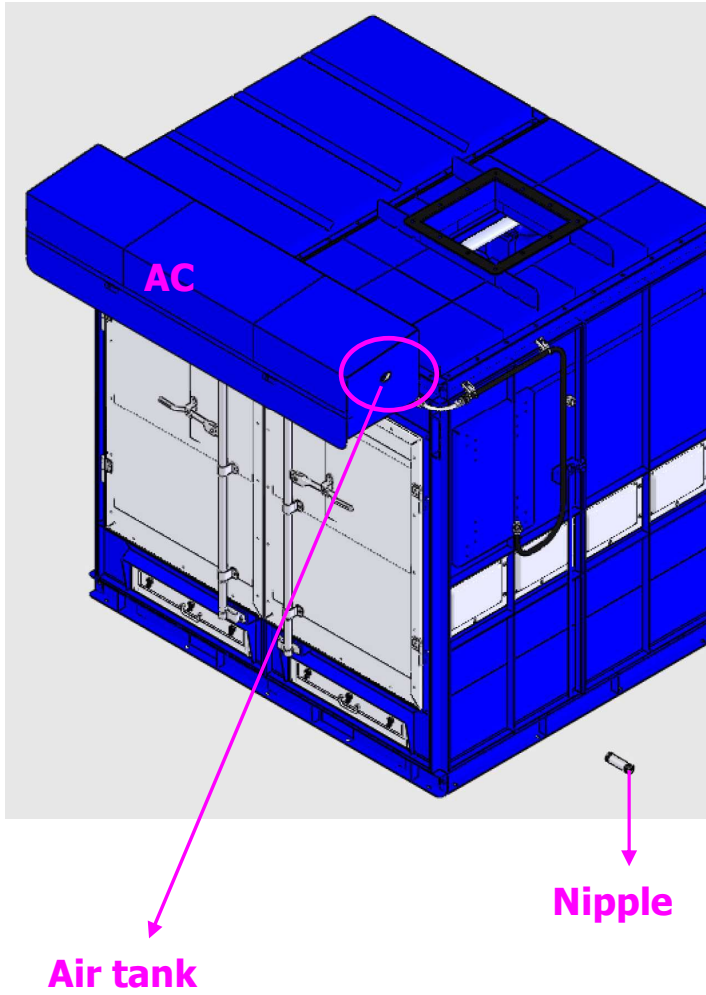

✚ Installations for the unit for SDC-15-16.



✚ Installations for the unit for SDC-15-16.

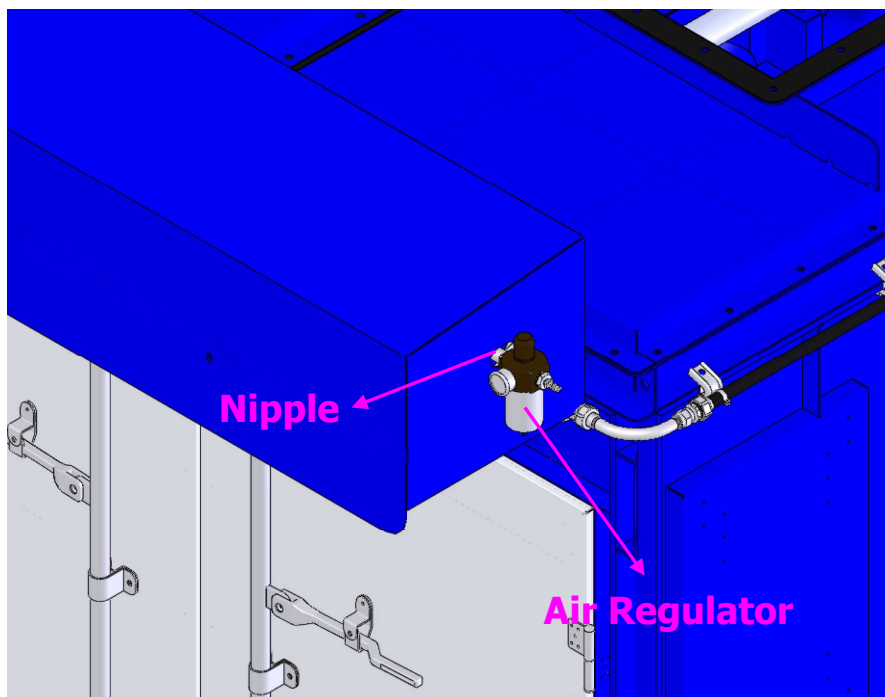
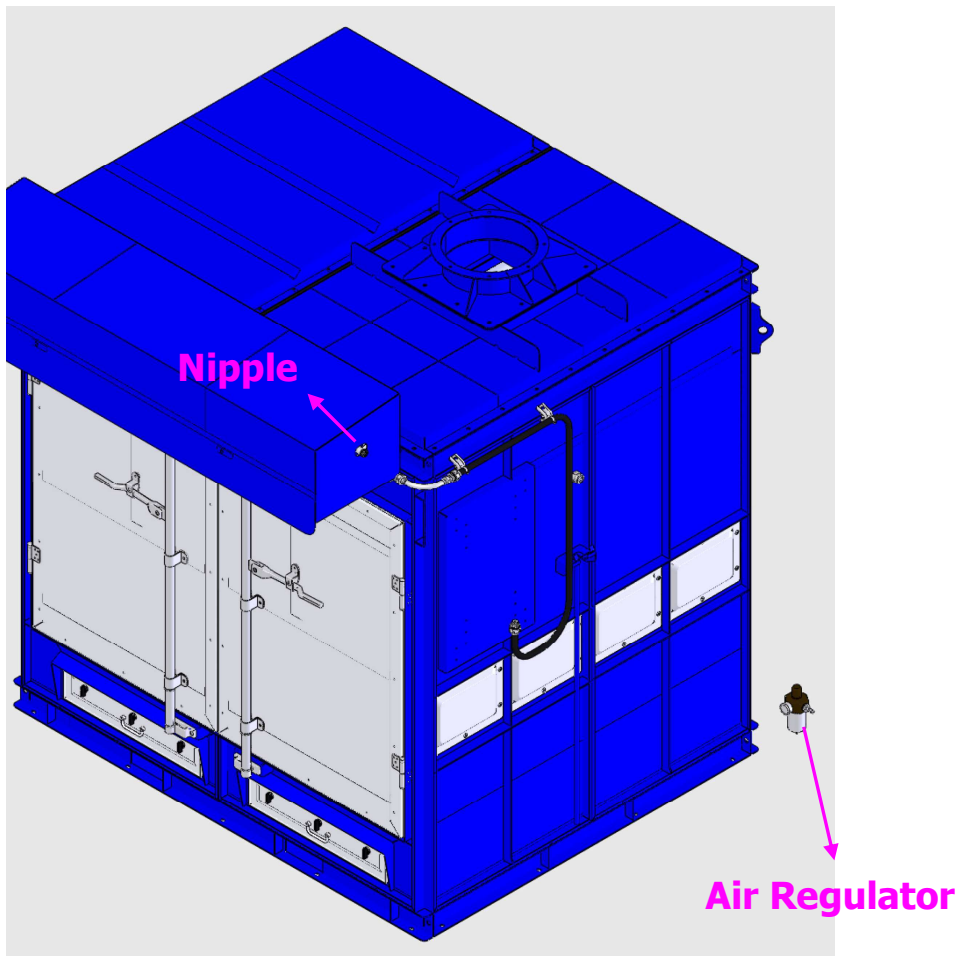

- Take out the **Air Regulator**.
- Fasten the **Air Regulator** to the nipple.



🔧 Installations for the unit for SDC-15-16.

- Assemble **upper unit** to **lower unit** using :

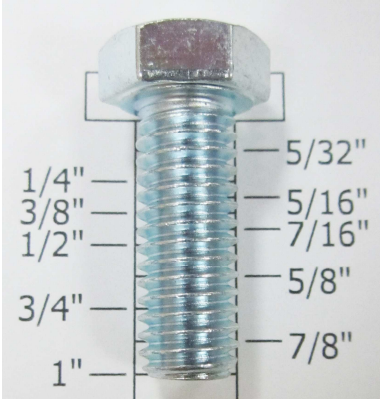
Hardware A

Part name	Description	Photo	Q'ty	Grainger Model #
Hex Screw	3/8" x 1"		50	1YU43
Flat Washer	3/8" x OD23 x 2T		100	*1JY33
Split Lock Washer	3/8"		50	6DYV1

Hex Nut	3/8"		50	2FE57
Rubber Washer	M12		50	

(*) Hardware item at similar spec available locally.

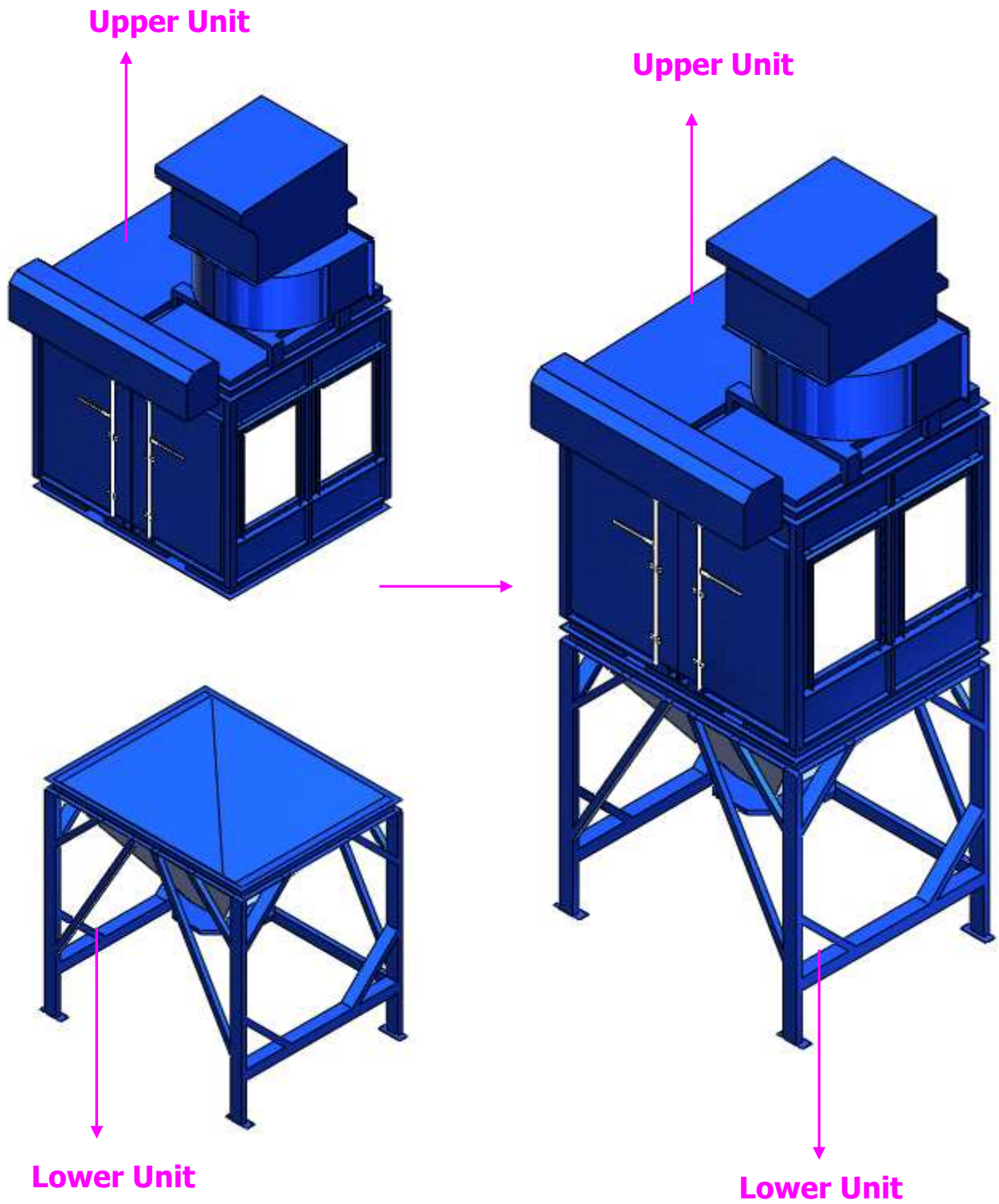

✚ Installations for the unit for SDC-15-16.



✚ Installations for the unit for SDC-15-16.

- Take out the number : **CQ** (Square To Round).
- Assemble **CQ** (Square To Round) to **Blower housing**

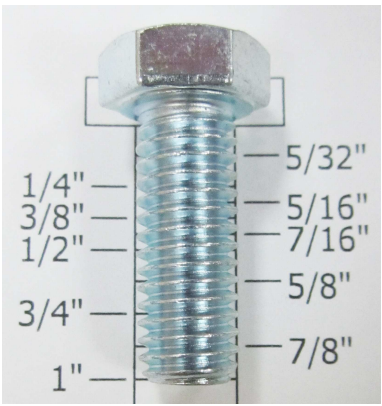
using :

Hardware D				
Part name	Description	Photo	Q'ty	Grainger Model #
Hex Screw	3/8" x 1"		14	1YU43
Flat Washer	3/8" x OD23 x 2T		28	*1JY33
Hex Nut	3/8"		14	2FE57

(* Hardware item at similar spec available locally.

✚ Installations for the unit for SDC-15-16.

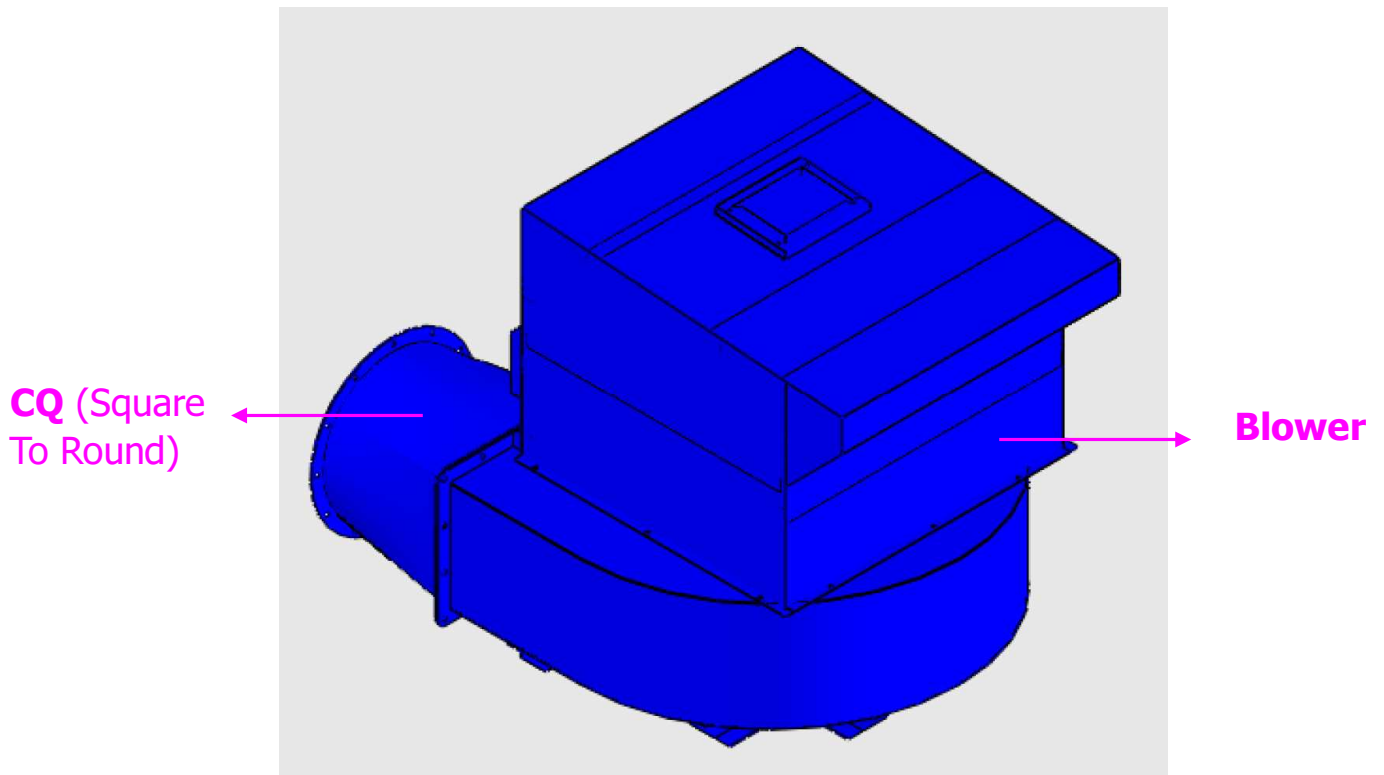
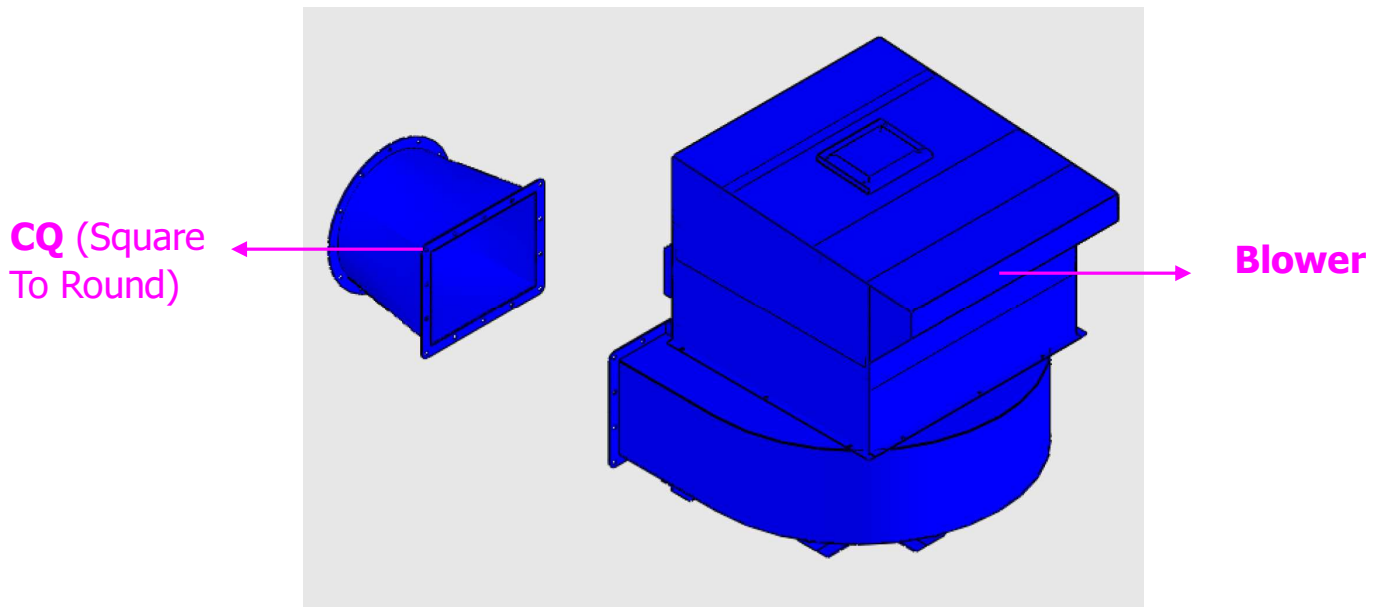



✚ Installations for the unit for SDC-15-16.

- Take out the **Flanged Connection**.
- Secure **Flanged Connection** to **Square To Round**

using :

-

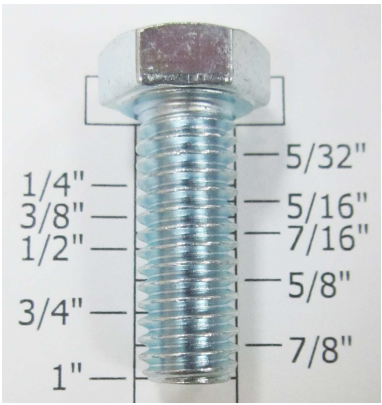
Hardware C

Part name	Description	Photo	Q'ty	Grainger Model #
Hex Screw	3/8" x 1"		12	1YU43
Flat Washer	3/8" x OD23 x 2T		24	*1JY33
Hex Nut	3/8"		12	2FE57

(* Hardware item at similar spec available locally.

✚ Installations for the unit for SDC-15-16.

Flanged Connection

CQ (Square To Round)

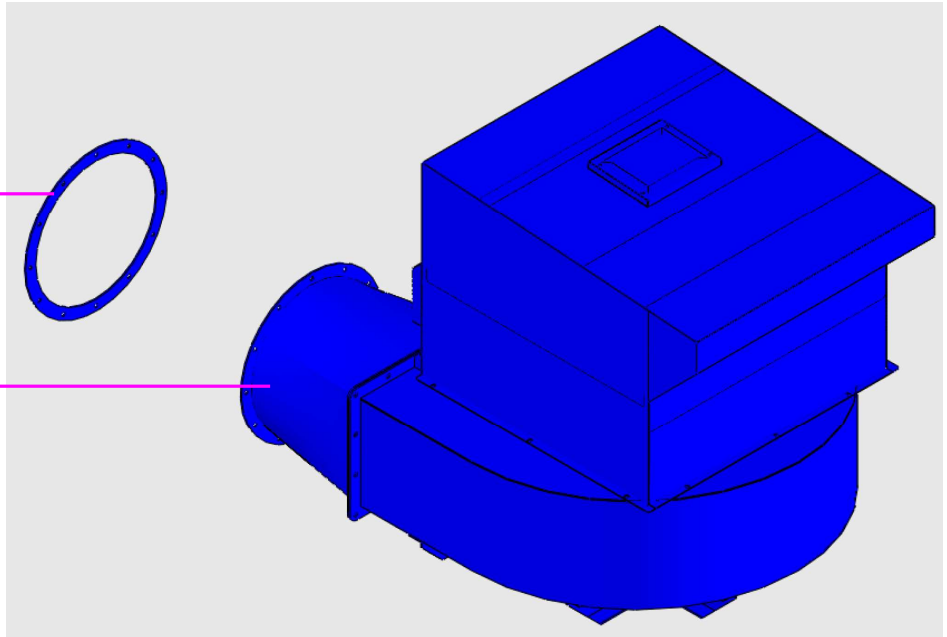



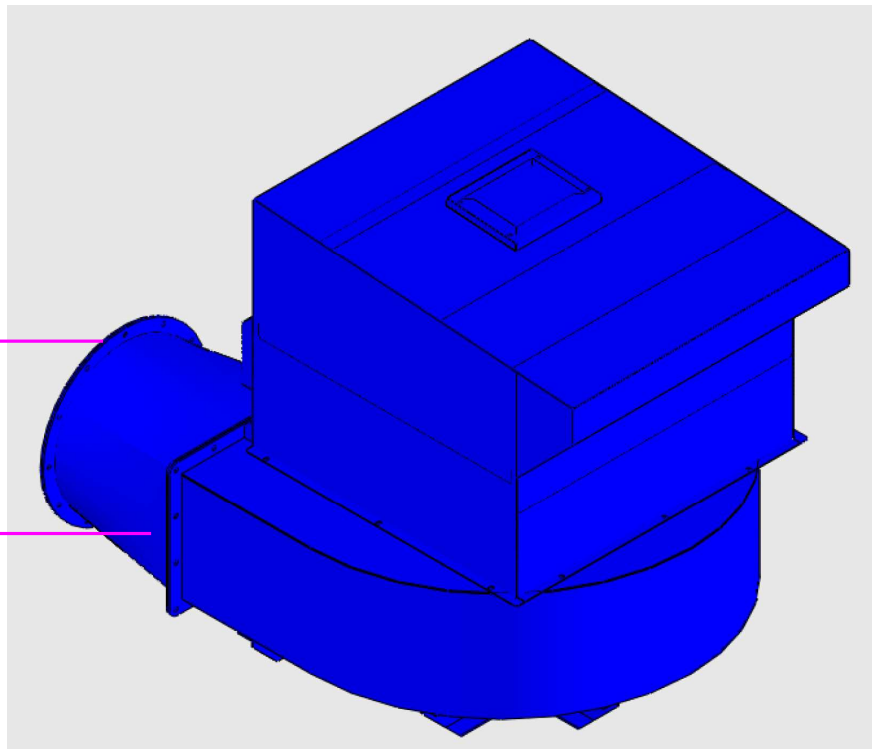

Flanged Connection

CQ (Square To Round)

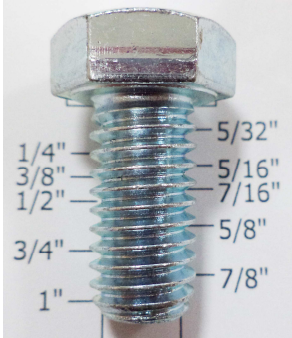

🔧 Installations for the unit for SDC-15-16.

- Assemble **Blower** to main unit using :

Hardware B				
Part name	Description	Photo	Q'ty	Grainger Model #
Hex Screw	1/2" x 1"		12	1YU61
Flat Washer	1/2" x OD25 x 2T		24	*1JY35
Split Lock Washer	1/2"		12	6FYC3
Hex Nut	1/2"		12	2FE67

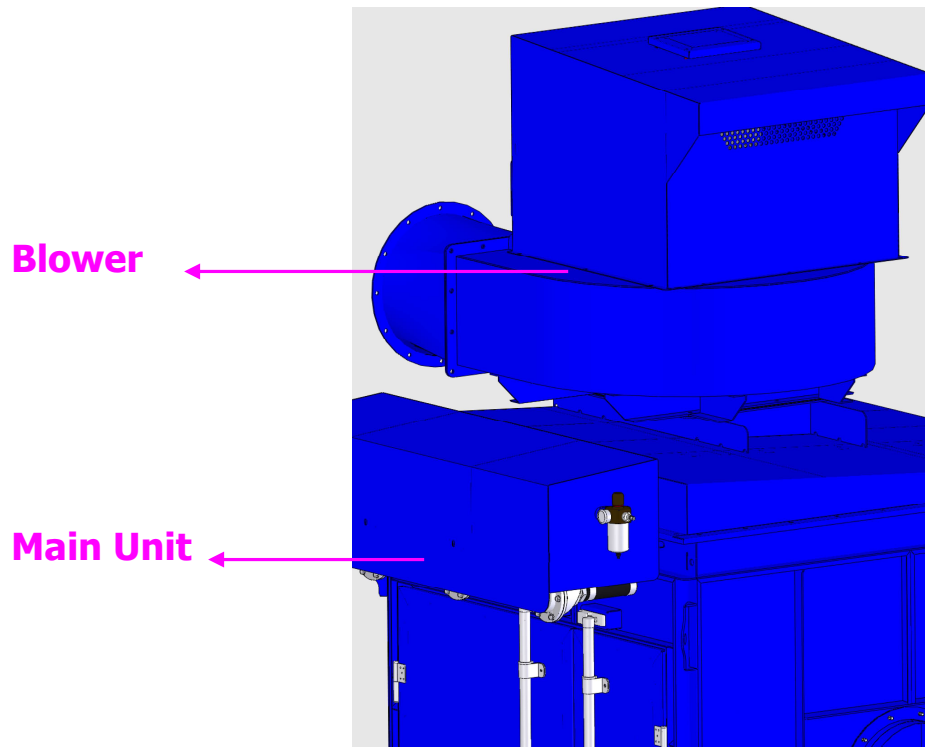
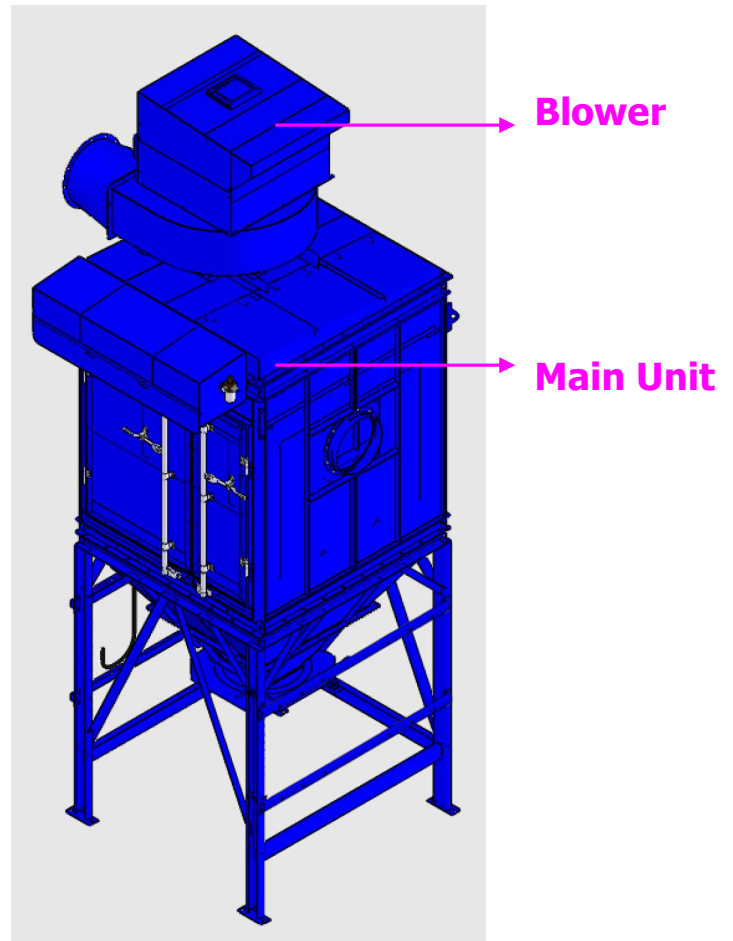
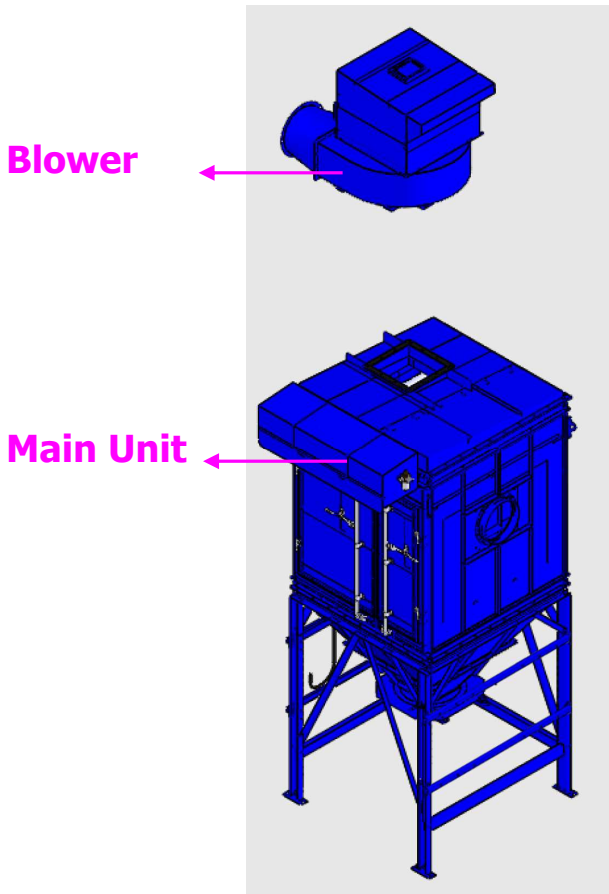

(* Hardware item at similar spec available locally.

Installations for the unit for SDC-15-16.

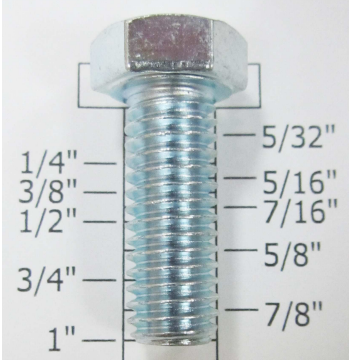

✚ Installations for the unit for SDC-15-16.

- Take out the number: **HP**.
- Assemble **HP** (lower hopper) to **upper hopper** using :
-

Hardware E				
Part name	Description	Photo	Q'ty	Grainger Model #
Hex Screw	3/8" x 1"		30	1YU43
Flat Washer	3/8" x OD23 x 2T		60	*1JY33
Hex Nut	3/8"		30	2FE57

(* Hardware item at similar spec available locally.

Installations for the unit for SDC-15-16.

Complete Assembled

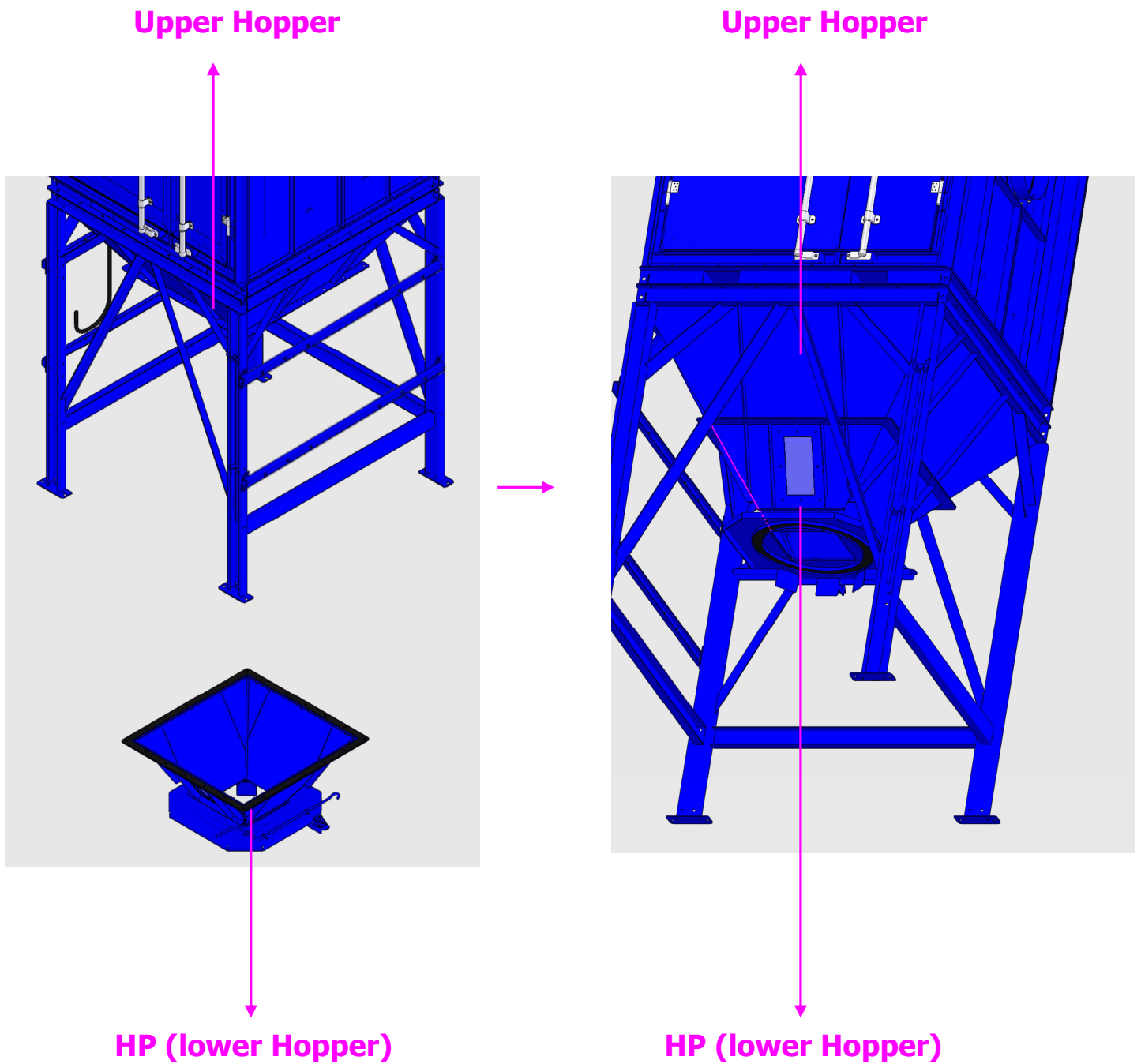

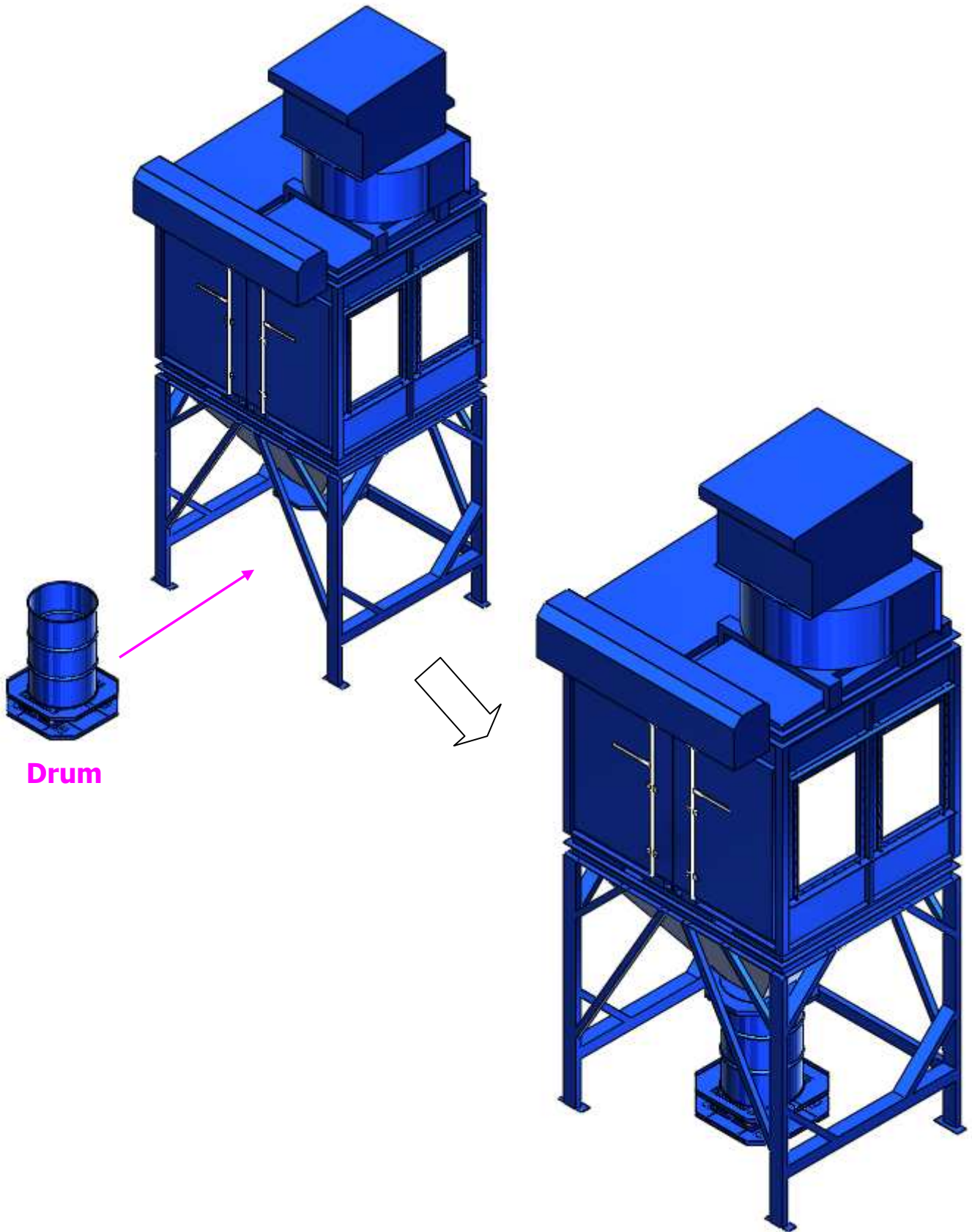

✚ Installations for the unit for SDC-15-16.



Drum

✚ Installations for the unit for SDC-15-16.

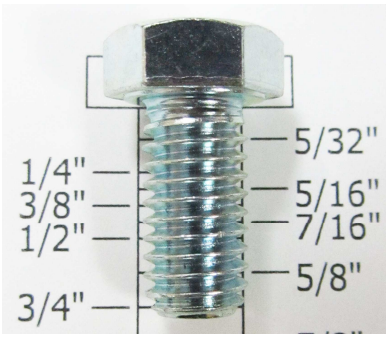
- Take out the Cartridge Collector Pulse Control Box Base.
- Assemble the Cartridge Collector Pulse Control Box Base, Supports and Cover using :

Hardware F				
Part name	Description	Photo	Q'ty	Grainger Model #
Hex Screw	3/8" x 3/4"		6	1YU42
Flat Washer	3/8" x OD23 x 2T		6	*1JY33

(* Hardware item at similar spec available locally.

Installations for the unit for SDC-15-16.

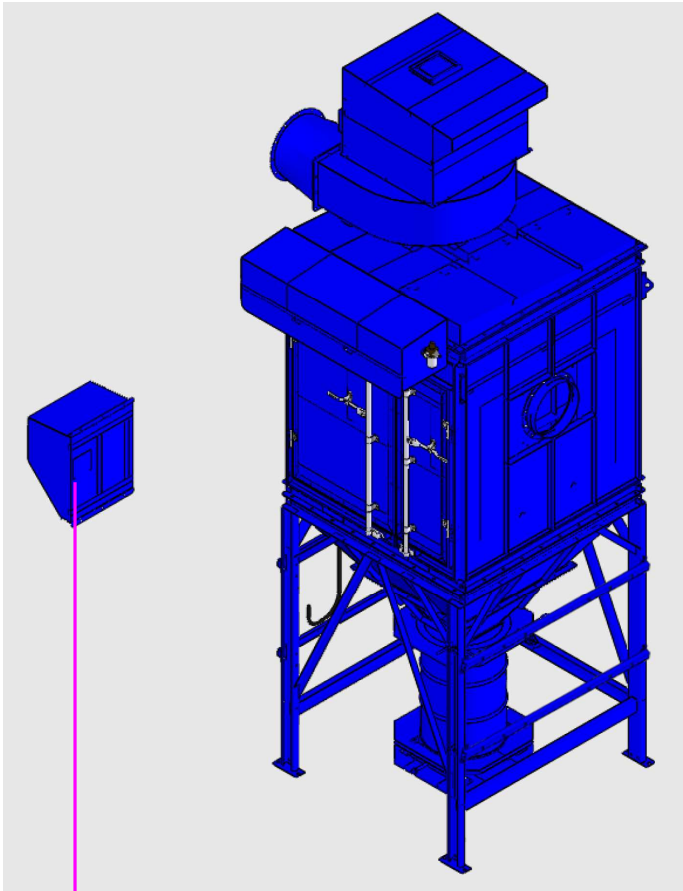

Pulse Control Box Base

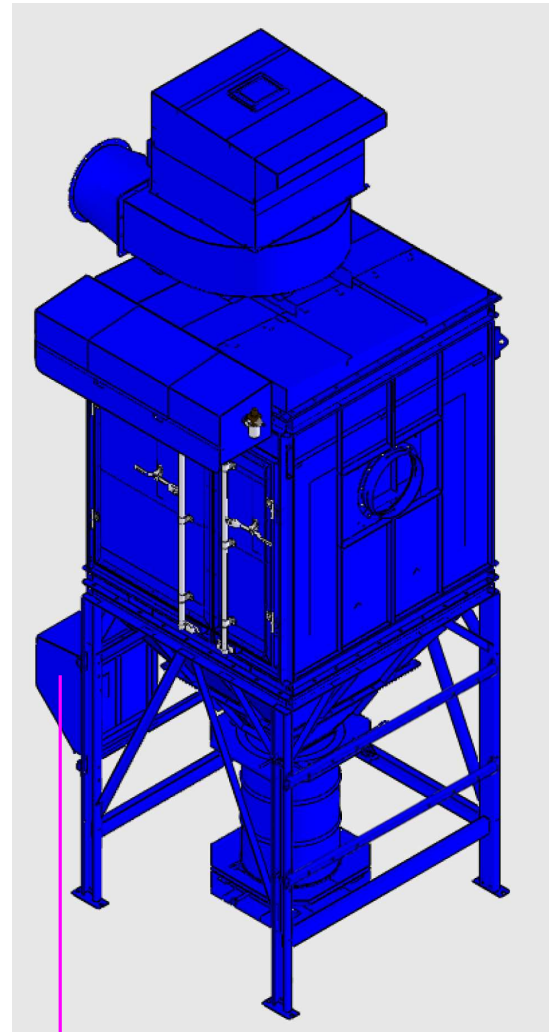

Pulse Control Box Base

✚ Installations for the unit for SDC-15-16.

- Fasten sleeve anchors for legs to field bolted if needed.

Part name	Description	Photos	Q'ty	Grainger Model #
Sleeve Anchor	3/4" x 4"		8	2G524

✚ Installations for the unit for SDC-15-16.

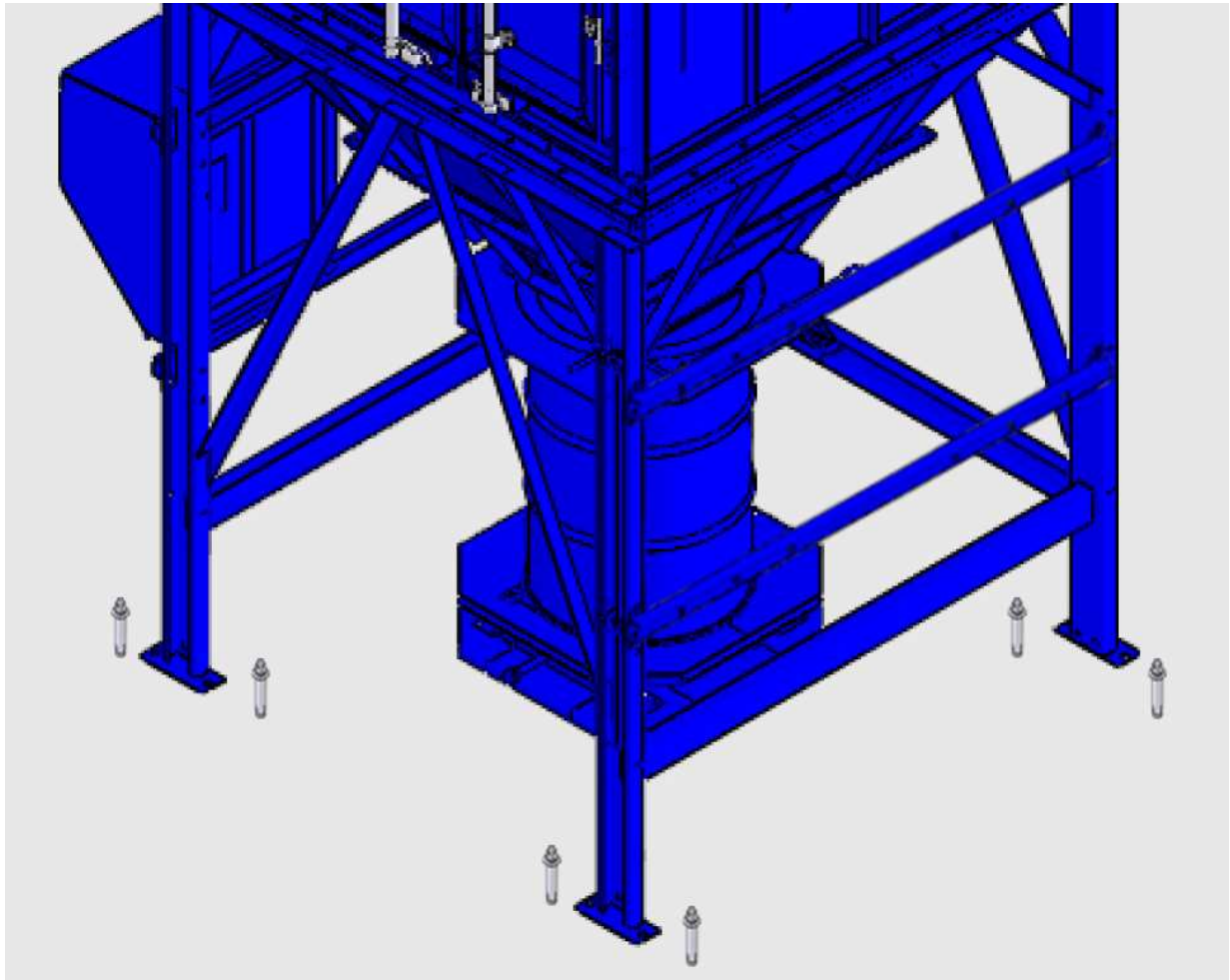

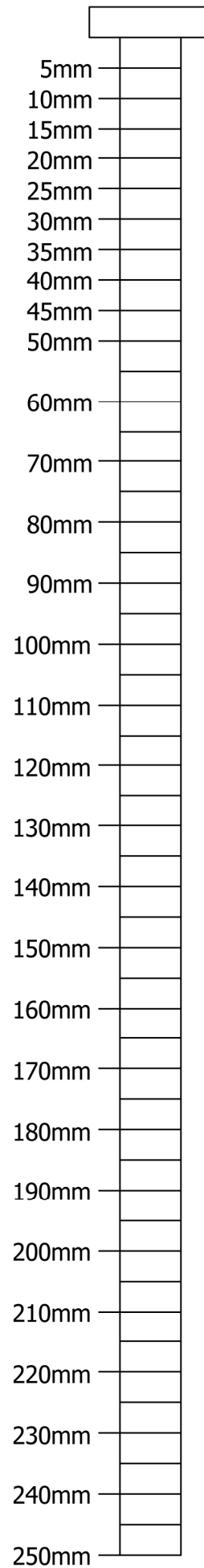
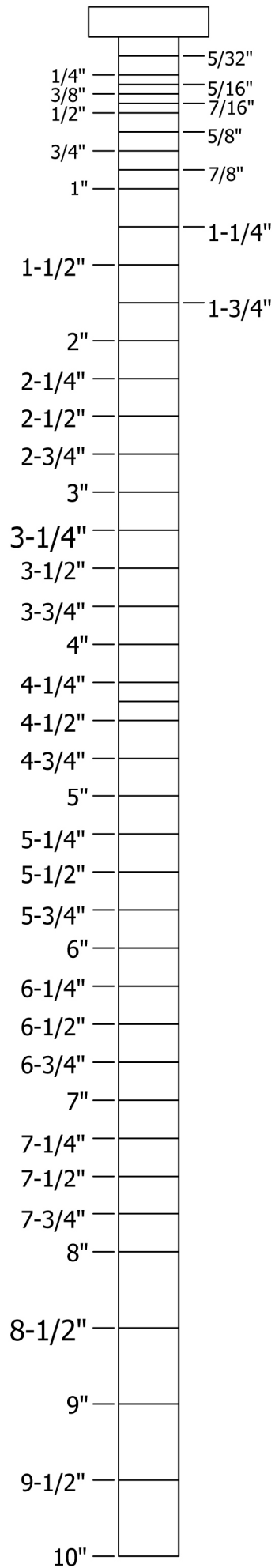

Flat Washer: 1/4"

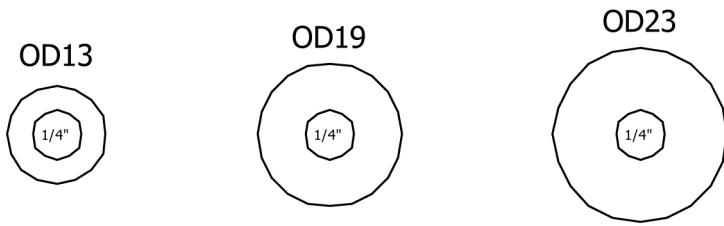

Flat Washer: 5/16"

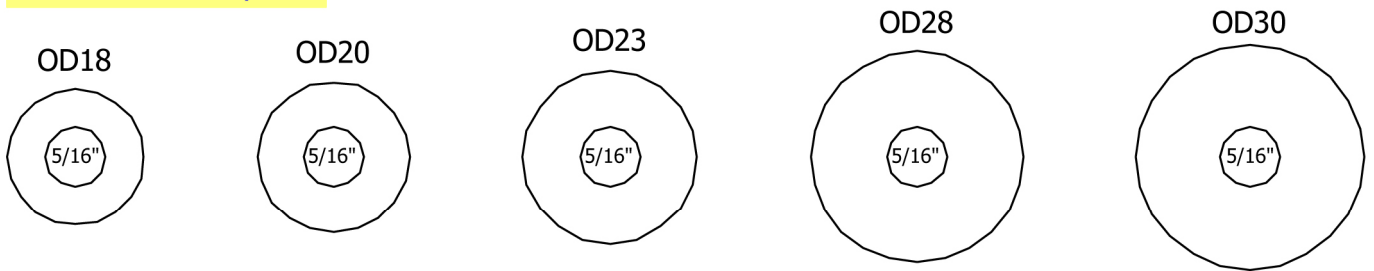

Flat Washer: 3/8"

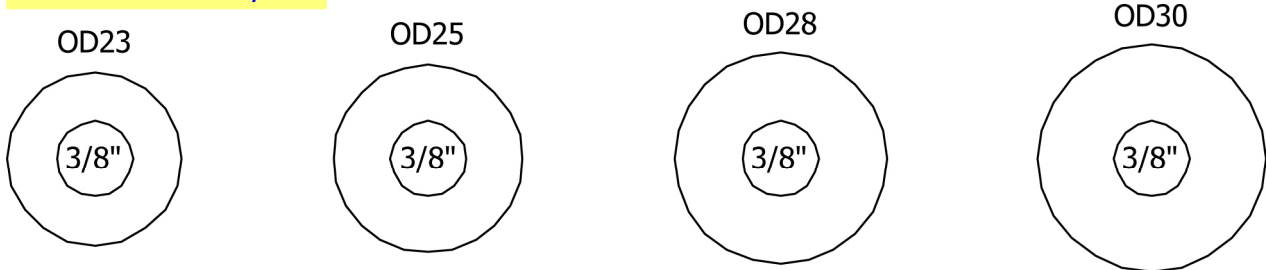

Flat Washer: 1/2"

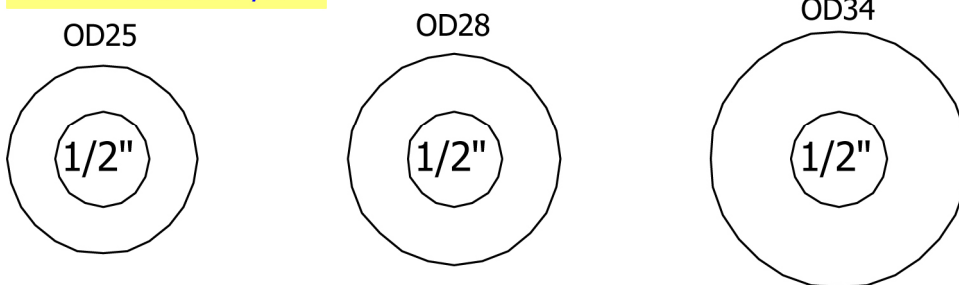

Flat Washer: 7/16"

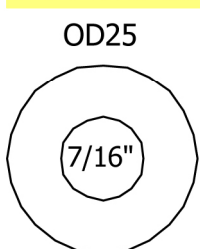

Flat Washer: 5/8"

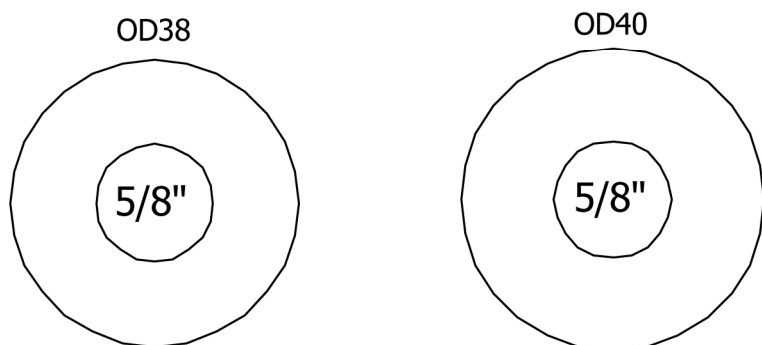

HEX NUT

3/16"



HEX NUT

1/4"



HEX NUT

5/16"

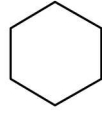

HEX NUT

3/8"

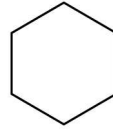

HEX NUT

1/2"

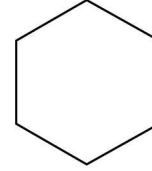

HEX NUT

5/8"

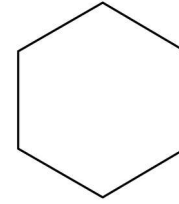

HEX NUT

NYLON HEX NUT

1/4"



NYLON HEX NUT

5/16"

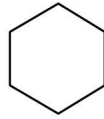

NYLON HEX NUT

3/8"



NYLON HEX NUT

1/2"

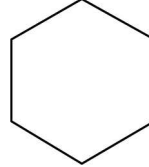

NYLON HEX NUT

5/8"

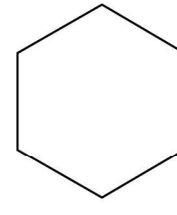

NYLON HEX NUT

ACORN NUT

1/4"



ACORN NUT

5/16"

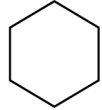

ACORN NUT

3/8"

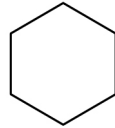

ACORN NUT

1/2"

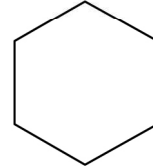

ACORN NUT

5/8"

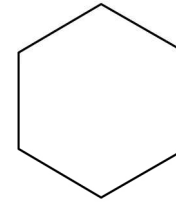

ACORN NUT

WING NUT

1/4"



WING NUT

5/16"



WING NUT

3/8"



WING NUT

Rubber Washer

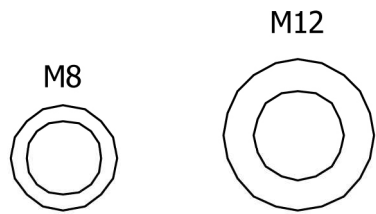

Split Lock Washer

