

AVANI Large Cartridge Collector



Customer:	102503, 10		
Customer PO#:			
AVANI SO#:		Tested By:	
Serial #:	122503-01 / 122801-01 (pulse control box)		
	122503-02 / 122801-02 (blower control box)		
Ship Date / Install Date:			

Please read and save these instructions. Read carefully before attempting to assemble, install, operate or maintain the product described. Protect yourself and others by observing all safety information. Failure to comply with instructions could result in personal injury and/or property damage! Retain instructions for future reference.



AVANI Large Cartridge Collector

General Safety Information

MACHINE WARNING SIGNS

▲ DANGER

Indicates an imminently hazardous situation which, if not avoided, will result in death or serious injury.

▲ WARNING

Indicates a potentially hazardous situation which, if not avoided, could result in death or serious injury.

▲ CAUTION

Indicates a potentially hazardous situation which, if not avoided, may result in minor or moderate injury.

Used without the safety alert symbol (▲) indicates potentially hazardous situation which, if not avoided, may result in property damage.



Warning of electric shock



Do not expose the equipment to rain or use in damp locations.



Do not use the equipment around flammable products, if not avoided, sparks can ignite vapors from flammable products. Read and understand all warnings and operating instructions before using this equipment. Failure to follow all instructions may result in electric shock, fire, and/or serious personal injury or property damage.

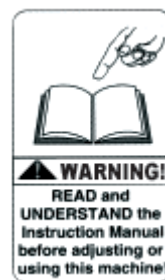

Figure 1

Please read and save these instructions. Read carefully before attempting to assemble, install, operate or maintain the product described. Protect yourself and others by observing all safety information. Failure to comply with instructions could result in personal injury and/or property damage! Retain instructions for future reference.



avani
environmental

SMT-20120628, SMT-20120712

AVANI Large Cartridge Collector

TABLE OF CONTENT

MACHINE WARNING SIGNS	2
Specifications.....	3
ADDITIONAL CARTRIDGE COLLECTOR SAFETY RULES.....	7
Assembly.....	8
Installation	8
ELECTRICAL INSTALLATION.....	8
Operation	9
Control Panel.....	12
Assembly Hardware	13
Assembly Procedure for Fan/Motor Assembly.....	14
Blower Curves.....	15
Repair Parts Illustration	16
Repair Parts List.....	17
Technical Data for Repair Parts.....	18
Appendix 1 - Electrical Circuit Diagram	24
Contact Information	35

Specifications

Motor	20 HP
.....	460V / 60Hz / 3Ph
Air Volume (C.F.M.)	8500 Ft ³ /Min @ 8" SP
Inlet Size	450 mm (dia. 17.7")
UL Individual Control Boxes for Cartridge Collector and Blower	

Please read and save these instructions. Read carefully before attempting to assemble, install, operate or maintain the product described. Protect yourself and others by observing all safety information. Failure to comply with instructions could result in personal injury and/or property damage! Retain instructions for future reference.

avani
environmental

SMT-20120628, SMT-20120712



AVANI Large Cartridge Collector

Cartridge Filter: Ø325mm x 1320mm x 16pcs (Ø12.8" x 52" x 16pcs)

Material: Polyester with TEFLON coating.

Filter Area: 19m² x 16 = 304m² (3271.04 ft²)

Pleat Depth: 48mm

Horizontal Positioned Filters,
Continuous Welded Seams,
Gasket and Latched Doors,
Powder Coated Paint and
Reverse Jet Pulse Cleaning

Include:

- Filter Chamber
- Inlet Square Pipe (need dimensions)
- Fan/motor combinations

No. of Valves: 4

Compressed Air Requirement: 90 PSI

Compressed Air Reservoir: 15.8 gallon

Inlet Air: 3/4"

Construction: 13 Gauge for panel; 11 Gauge Steel Cabinet

Max. Operating Temp.: 120°C

Paint Color: Avani Blue

Dimension (L x W x H): 102.2" x 123.7" x 180.6" (2593.5 x 3140.5 x 4584.8mm)

***with Feet Underneath the machine.

***1" connector welded to the right side of the collector

***w/ silencer

AVANI Large Cartridge Collector

***Roll Media: RM-6000

***VFD

***Pulse control box run off of 120V, 60HZ, 1-phase, no transformer inside the pulse box. Pulse box located inside the building on the collector.

***Blower control box: 460V/ 60Hz / 3-phase, with transformer. Blower box located inside the building.

AVANI Large Cartridge Collector

General Safety Information

(Continued)

⚠ WARNING

Use this product carefully to

effectively avoid any possible danger. Observe the following safety regulations to avoid bodily injury due to electrocution during use.

Read this Manual carefully before operating the product and preserve the Operation Manual properly.

1. Keep work area clean and organized.
 - A disorderly working environment will cause inconvenience and danger during operation.
2. Check if the working environment is suitable for using the product.
 - Do not use the product in a humid environment.
 - Use the product in a good working environment to reduce risks.
 - Do not use the product in a flammable gas or liquid environment to avoid danger.
3. Keep other persons away from the

product, except for the operator, to avoid danger.

- Do not let children get close to the product. All wires used by the product shall be in a safe location to prevent children from touching them.
4. All tools shall be safely stored.
 - When the tools are not used, please store them in a dry place safely beyond the reach and access of children.
 5. If the machine breaks down, contact a service technician. Do not attempt to repair and possibly damage the machine.
 6. When using the product, be sure to put on a suit and mask.
 7. Use the electrical wires correctly.
 - During use, do not drag the electrical wires forcefully. Do not use these wires if fraying or current leakage occurs to avoid injury to the operator.
 8. Before replacing parts, shut off power to the machine.
 - Check that the switch is in "on" or "off" position. Do not attempt the replacement when the machine is

Please read and save these instructions. Read carefully before attempting to assemble, install, operate or maintain the product described. Protect yourself and others by observing all safety information. Failure to comply with instructions could result in personal injury and/or property damage! Retain instructions for future reference.

avani
environmental

SMT-20120628, SMT-20120712



AVANI Large Cartridge Collector

running. To replace parts or filter material, make certain that the switch is "off".

9. Use the power cord correctly. The total length of power cord shall not exceed 10 feet to avoid low power due to a drop in voltage and to prevent a possible hazard.

▲WARNING

When connecting the product, always follow the instructions in the Operation Manual to avoid injuries.

10. Care and Maintenance:

- Confirm that the parts/accessories have been fully assembled and will not adversely affect the machine operation.
- Check if the machine is operated properly.
- Replace damaged parts or accessories according to the instructions of the Manual. If the said instructions are not specified in the Manual, have a professional technician carry out the maintenance or replacement.
- Check that the electrical specifications of this machine meet safety requirements, and that the maintenance is carried out by a

professional technician. Use original manufacturer's parts and accessories to avoid injury.

- If a problem occurs, contact your dealer immediately.

ADDITIONAL CARTRIDGE COLLECTOR SAFETY RULES

The Cartridge Collector can be dangerous if it is operated incorrectly. Therefore, the product must be used cautiously to avoid causing a hazard or damage. Unnecessary injuries may occur by failing to follow the instructions of the Safety Rules Manual. Be sure to put on protection equipment or suit that can protect your body, such as helmet and eye mask to avoid injuries from occurring. If any doubts or any unfitness occurs during use, be sure to stop the operation immediately. Keep in mind that the user shall be liable for using according to the specified safety rules and for operating the machine correctly.

1. Read this Manual carefully before operating the product.
2. Be sure to follow local electrical and safety regulations and observe the electrical safety standards practiced in the relevant area. All electrical wire

AVANI Large Cartridge Collector

connections and installation shall be carried out by a professional technician.

3. Do not operate the product near flammable materials, as sparks may ignite these materials and cause an explosion. Please confirm there aren't any flammables near the working site to avoid hazard.
4. This product is suitable for collecting smoke and oil gas. Do not use it in collecting iron chips and dust at the same time to avoid producing sparks.
5. Before replacement of parts or filter materials, be certain that the switch is disconnected.
6. Do not kink the power cord and keep it away from oil, chemicals or flammables.
7. Check that the voltage, phase count and grounding wire match the machine requirements.
8. When the fan blades are operated at high speed, do not reach hand near these blades to prevent finger from breaking or clothes/necktie from getting caught. Do not put the hand or foreign matter into the air inlet to avoid getting caught in the high-speed rotation of fan blades.

9. When not in use, all air inlets of Cartridge Collector shall be covered.

Assembly

Do not connect the Cartridge Collector

▲WARNING

before the assembly is

finished and you have read and understood all of the precautions stated in the Manual.

NOTE: For correct assembly, refer to the Assembly Procedure.

Installation

MOVING AND TRANSPORTATION

The weight of this machine is about 5,026.5 lbs. It CANNOT be handled and transported without the help of lifting tools. For your safety, read all instructions carefully.

Do not move without the help of others

▲WARNING

to avoid causing danger.

ELECTRICAL INSTALLATION

POWER CONNECTION

1. Confirm that the power is properly connected under normal power supply condition. It is recommended to provide manual shutdown device before connecting power.

AVANI Large Cartridge Collector

2. It is recommended to protect the control equipment with suitable grade of fuse, and the length of fuse and power cord shall not be over 10 feet.

SHUTDOWN

1. Disconnect power by manual method.
2. When stopping operation, check if the switch is under off status.

EARTHING WIRE

Connect yellow/green wires to the earthing wire power jack. Confirm that the earthing wire has been properly connected before connecting main power cord to the machine at all times.

⚠ WARNING

Do not disconnect the wiring jack

before cutting off power!

POWER INSTALLATION AND STORAGE

The electrical power is configured as following. If conditions are beyond the scope stated below, then it is required to ensure that the power is well arranged and safe.

- Ambient temperature: Between 41°F and 131°F. If the time is over 24 hours, then the ambient average temperature shall not be over 122°F.
- Humidity: Between 30% and 95%
- Altitude: 3,280 feet

- Moving and Storing: -13°F to 131°F. For short-time storage (less than 24 hours), the storage temperature can be up to 158°F.

Operation

PRIOR TO START UP

Purpose: The Cartridge Collector is specially suitable for treating the smoke generated during ordinary processing work, which can effectively collect and screen the smoke resulting from the work in maintaining the air quality of the working environment.

- Before starting the machine, be sure to read this Manual carefully.
- Before starting the machine, check if relevant safety protection measures have been taken according to the Manual.
- Before starting the machine, watch the motor turning direction according to the instruction of arrow direction.

START UP

1. To ensure satisfactory performance for the Cartridge Collector, please confirm the air volume, power and the matching table of the Cartridge Collector.
2. Connect power according to electrical

AVANI Large Cartridge Collector

installation procedure after installing the Cartridge Collector and the blower.

Disconnect power according to electrical installation procedure when the machine is not used.

3. The Cartridge Collector shall be turned on and off by pushing I/O button. Under normal operation status, use such I/O button.

FILTER CLEANING

1. Attach compressed air to the unit for cleaning purposes, at a source pressure of 90 PSI. The connection point is accessed by removing the panel on the side of the unit where the PSI label is in place and requires a 3/4" NPT fitting. A regulator must be incorporated in line to set pressure. Do not exceed 90 PSI pressure.



2. Refer to control panel for initiating power

to the motor and subsequent vacuum from the unit.

3. The pulse cleaning is used for filter cleaning and for maximum effectiveness should be used as follows:
 - Turn off ONLY the motor power and leave the main power on for approximately 1 hour until ALL cartridges are pulse-jet-cleaned. This ensures the cartridge cleaning efficiency when you turn on the power next time.
 - Cleaning as noted above should be daily or as any decrease in vacuum is observed.
 - If the collector has a gauge, cleaning is required when the gauge reads or is near 4" WC.
4. If operating vacuum is weak after pulse cleaning, contact AVANI for filter replacement. (See contact list in this manual)

Unpacking

The machine should be unpacked carefully. Check if the machine and components are consistent with those indicated in the Parts List. If any doubt arises or when the components are incomplete, contact your dealer.

AVANI Large Cartridge Collector

Dimensions (in mm/inches)

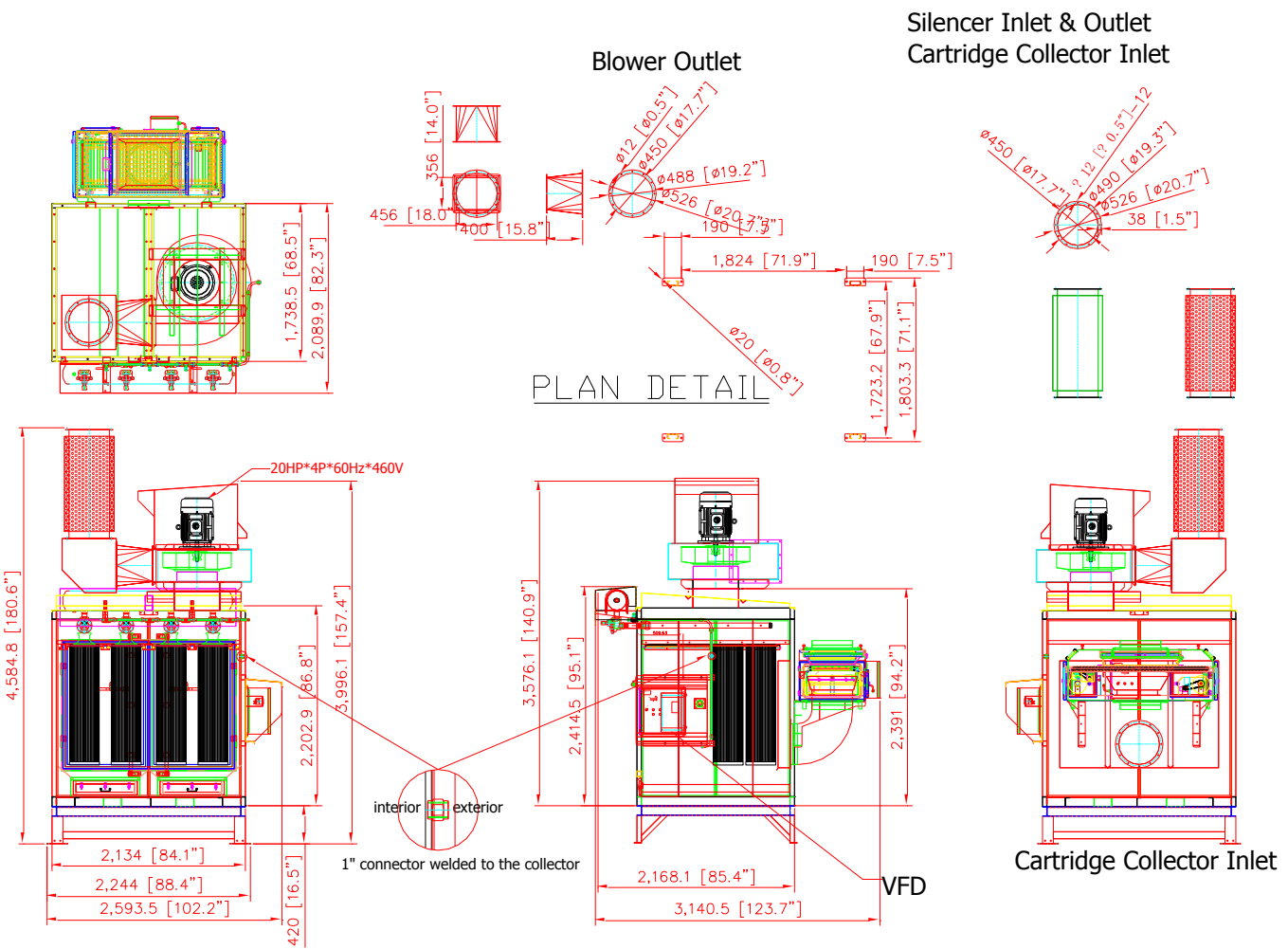

AVANI Large Cartridge Collector

Control Panel

Time Setting for Valve (Pulse-Jet):

1. No. of Valves: 4
2. Pulse-jet Time for each Valve: 0.2 sec
3. Valve Interval: 30 seconds (pulse-jets first cycle when turning on the power and circulate in every thirty seconds).
4. Turn off ONLY the motor power and leave the main power on for approximately 1 hour until ALL cartridges are pulse-jet cleaned. This ensures the cartridge cleaning efficiency when you turn on the power next time.

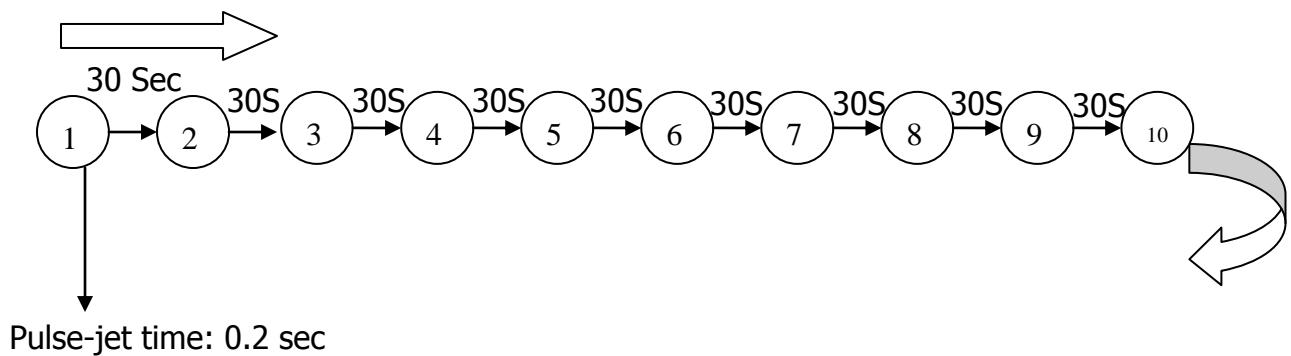

AVANI Large Cartridge Collector

Assembly Hardware

Johnson Controls - SDC-20-16MDF w/ RM-6000					
No.	Model	Part Name	Specification	Q'ty	Remark
1	SDC-20-16MDF	Sleeve Anchor	3/4"*4"	4	Bolted on the Ground
2	SDC-20-16MDF	Hex Screw	1/2"*1"	12	Adjacence of Blower and Blower Base
		Flat Washer	1/2"*OD25*2T	24	
		Lock Washer	1/2"	12	
		Hex Nut	1/2"	12	
3	SDC-20-16MDF	Hex Screw	3/8"*3/4"	6	Adjacence of Pulse Control Panel and Machine Body
		Flat Washer	3/8"*OD23*2T	6	
4	SDC-20-16MDF	Hex Screw	3/8"*1"	14	Adjacence of Blower and Square to Round
		Flat Washer	3/8"*OD23*2T	28	
		Hex Nut	3/8"	14	
5	SDC-20-16MDF	Hex Screw	3/8"*1"	12	Adjacence of Square to Round and 90 degree Elbow
		Flat Washer	3/8"*OD23*2T	12	
6	SDC-20-16MDF	Hex Screw	3/8"*1"	12	Adjacence of 90 degree Elbow and Silencer
		Flat Washer	3/8"*OD23*2T	12	
7	SDC-20-16MDF	Hex Screw	3/8"*1"	12	Adjacence of Flange and Silencer
		Flat Washer	3/8"*OD23*2T	24	
		Hex Nut	3/8"	12	
8	SDC-20-16MDF	Hex Screw	1/2"*1"	32	Adjacence of Feet and Feet
		Flat Washer	1/2"*OD25*2T	64	
		Hex Nut	1/2"	32	
9	SDC-20-16MDF	Hex Screw	1/2"*1"	28	Adjacence of SDC-20-16MDF and Feet
		Flat Washer	1/2"*OD25*2T	56	
		Hex Nut	1/2"	28	
10	SDC-20-16MDF	Sleeve Anchor	3/8"*3"	4	Bolted Blower Control Panel Base to the Wall
11	RM-6000	Hex Screw	3/8"*1"	16	Adjacence of RM-6000 and RM-6000 Fixing Base
		Flat Washer	3/8"*OD23*2T	16	
		Lock Washer	3/8"	16	
12	RM-6000+ SDC-20-16MDF	Hex Screw	1/2"*1"	6	Adjacence of SDC-20-16MDF and RM-6000 Fixing Base
		Flat Washer	1/2"*OD25*2T	6	

AVANI Large Cartridge Collector

Assembly Procedure for Fan/Motor Assembly

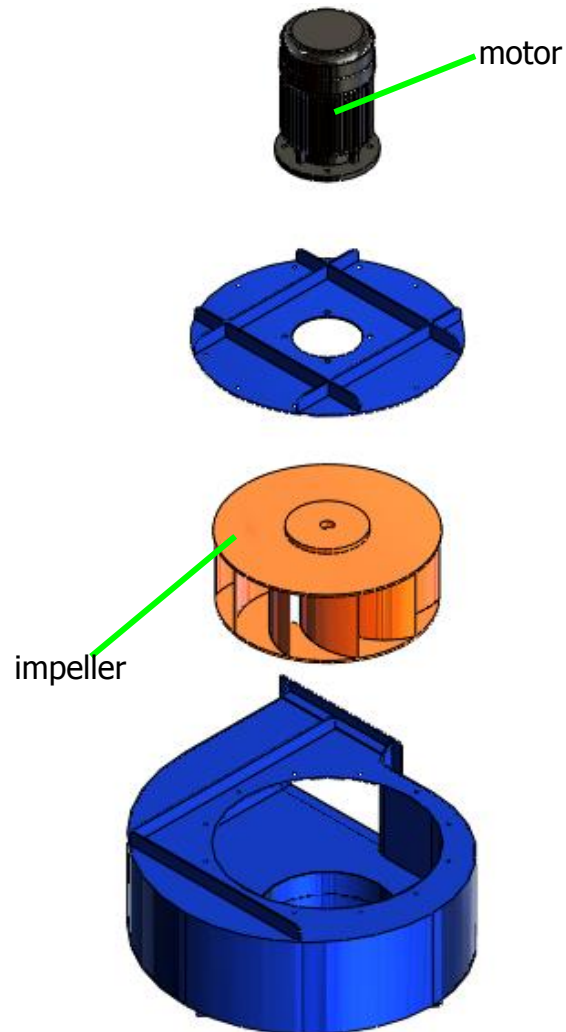

AVANI Large Cartridge Collector

Blower Curves

SDC-20-16MDF DUST COLLECTOR

Model	Max static pressure (inch/H2O)	Max CFM	Hp	Volts	Hz	Impeller	Inlet
SDC-20-16MDF DUST COLLECTOR	8"	8500	20HP x 1 pc	460V	60		

SDC-20-16MDF	Static pressure (Inch/H2O)	8	7	6	5
	CFM	8500	9500	11300	

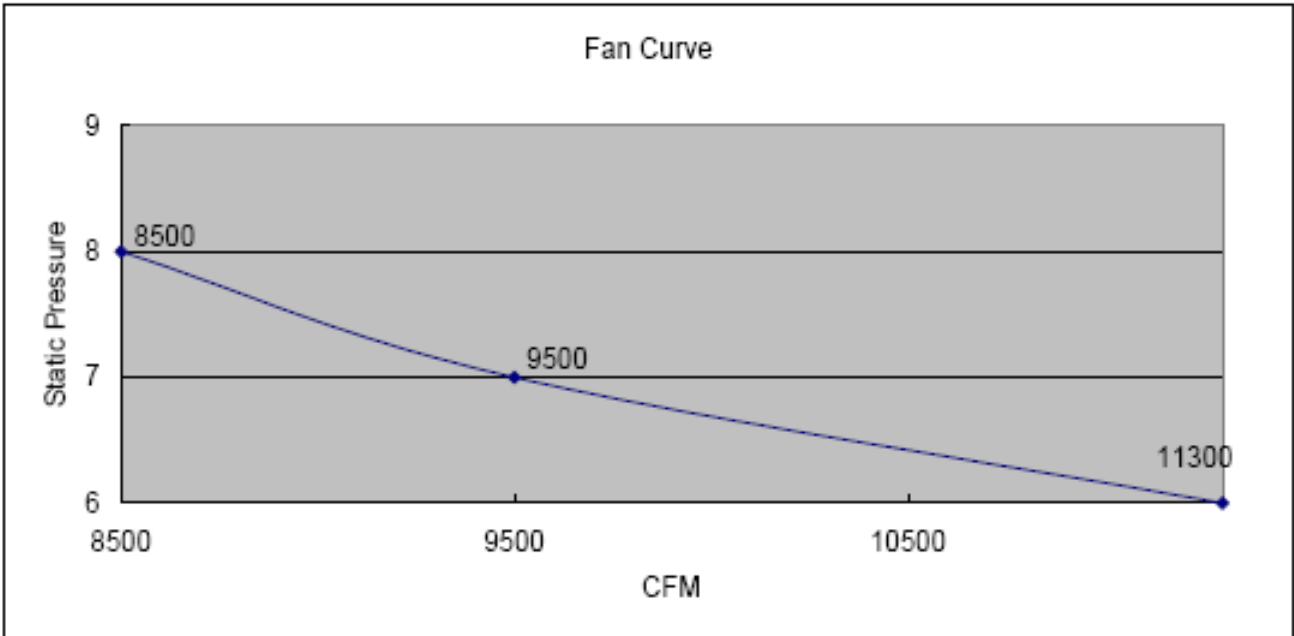

AVANI Large Cartridge Collector

Repair Parts Illustration

For Repair Parts, call +1-919-570-2862

24 hours a day – 365 days a year

Please provide following information:

- Model number
- Serial number (if any)
- Part description and number as shown in parts list

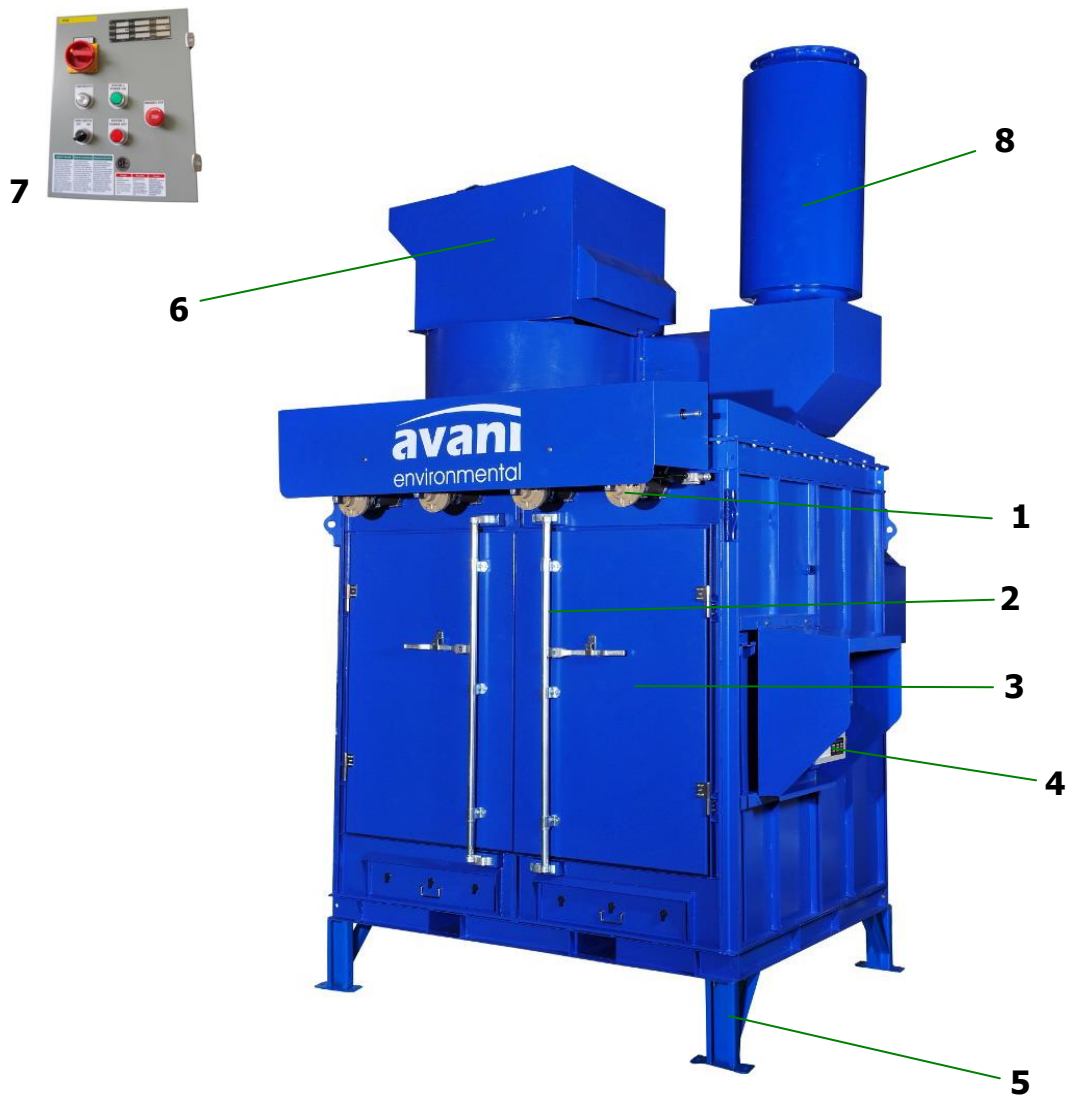

AVANI Large Cartridge Collector

Repair Parts List



Repair Parts List for Dust Collector

Reference Number	Description	Part Number	Quantity
1	Solenoid Valve	AVANI-SDC-20-16MDF-1	4
2	Door Locker	AVANI-SDC-20-16MDF-2	2
2-1	Door Locker Kit	AVANI-SDC-20-16MDF-2-1	2
2-2	Door Locker Kit	AVANI-SDC-20-16MDF-2-2	1
2-3	Door Locker Kit	AVANI-SDC-20-16MDF-2-3	2
2-4	Door Locker Kit	AVANI-SDC-20-16MDF-2-4	2
2-5	Door Locker Kit	AVANI-SDC-20-16MDF-2-5	1
2-6	Door Locker Kit	AVANI-SDC-20-16MDF-2-6	1
2-7	Door Locker Kit	AVANI-SDC-20-16MDF-2-7	1
3	Cartridge Filter	AVANI-SDC-20-16MDF-3	16
3-1	Filter Handle (left)	AVANI-SDC-20-16MDF-3-1	1
3-2	Filter Handle (right)	AVANI-SDC-20-16MDF-3-2	1
4	Control Box for Air Pulse Solenoid Valves of the Large Cartridge Collector	AVANI-SDC-20-16MDF-4	1
5	Feet	AVANI-SDC-20-16MDF-5	4
6	Blower and Motor	AVANI-SDC-20-16MDF-6	1
7	Control Box for Blower and Motor	AVANI-SDC-20-16MDF-7	1
8	Noise Reducer	AVANI-SDC-20-16MDF-8	1

AVANI Large Cartridge Collector

Technical Data for Repair Parts

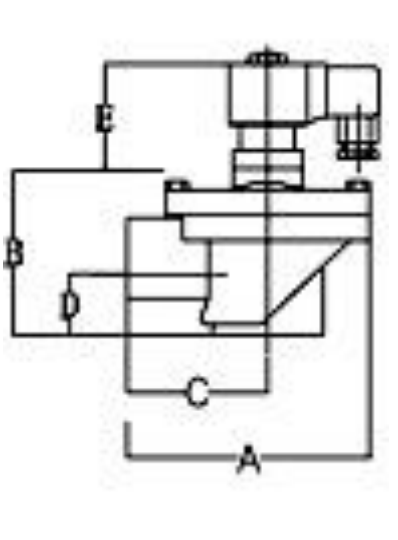
Reference Number	Description	Part Number	Quantity
1	Solenoid Valve	AVANI-SDC-20-16MDF-1	4

			
Model		LPDA50C	
INCHES		2"	
ORIFICE	A	186	
	B	145	
	C	103	
	D	46	
	E	73	

AVANI Large Cartridge Collector

Reference Number	Description	Part Number	Quantity
2	Door Locker	AVANI-SDC-20-16MDF-2	2

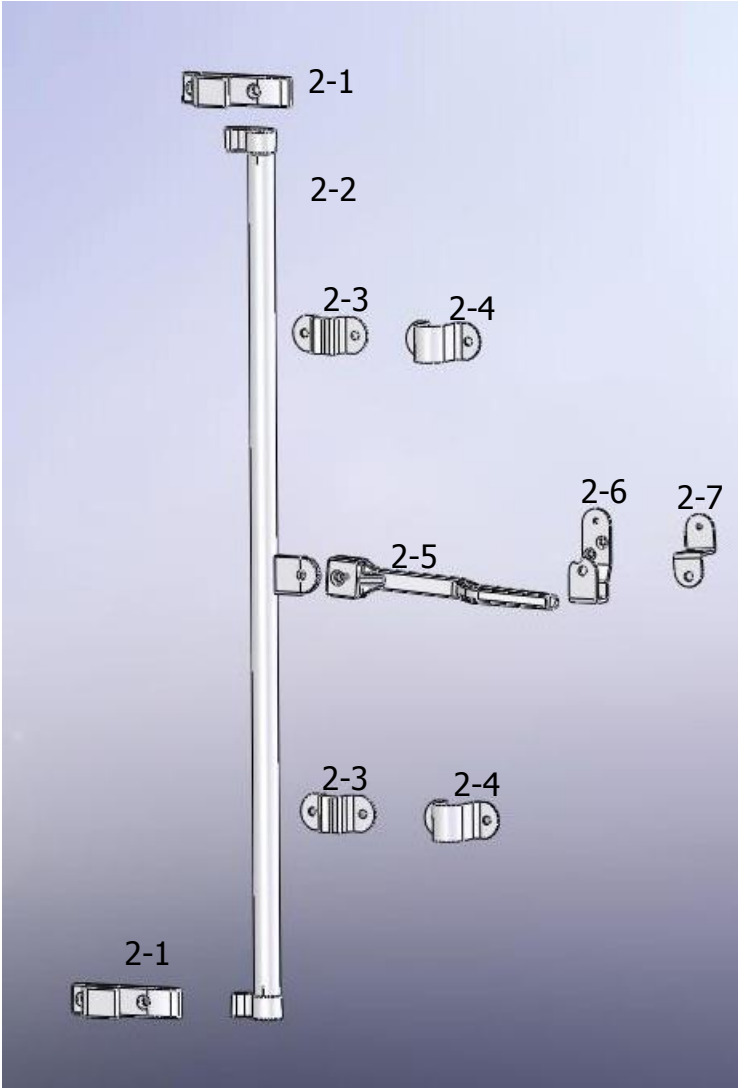

AVANI Large Cartridge Collector

Reference Number	Description	Part Number	Quantity
3	Cartridge Filter	AVANI-SDC-20-16MDF-3	16

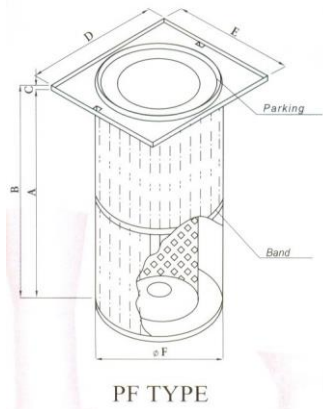

PF TYPE (Measurement m/m)

Diameter	Fold Depth	A	B	C	D	E	F	Weight kg	Filtering Area M ²
325	48	1307	1320	13	406	357	324	17	19

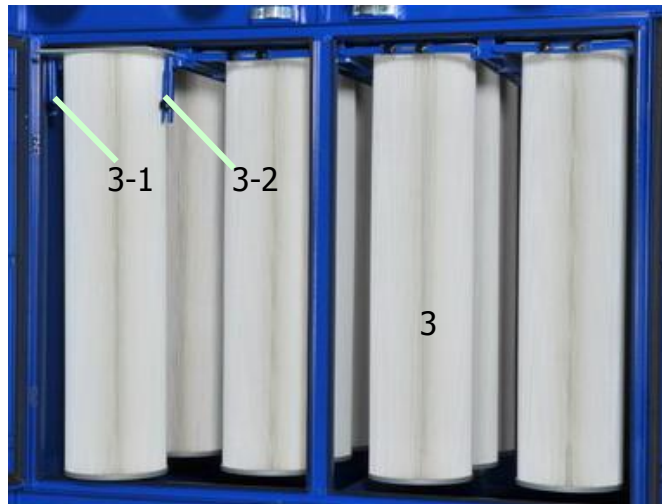

Reference Number	Description	Part Number	Quantity
4	Control Box for Air Pulse Solenoid Valves of the Large Cartridge Collector	AVANI-SDC-20-16MDF-4	1

See appendix for wiring diagram.

AVANI Large Cartridge Collector

Reference Number	Description	Part Number	Quantity
6	Blower and Motor	AVANI-SDC-20-16MDF-6	1

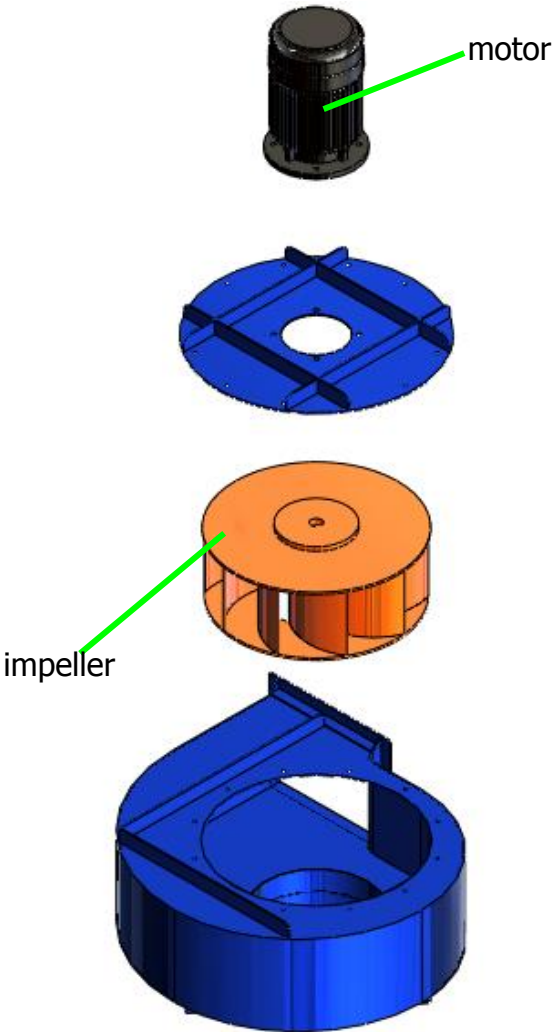

AVANI Large Cartridge Collector

<i>DO NOT SCALE</i>	<i>IF IN DOUBT ASK</i>		Revisions			
			Rev	Description	Date	Approved
			<p>DBN-200 blower 20HP x 1pc*4P*60Hz*230/460v</p>			
AVANI ENVIRONMENTAL INTL. INC. Sales Department 95 Cypress Drive (919) 570-2862 Youngsville, NC 27596 info@avanienvironmental.com			Drawn by: 2009-11-04 Checked by:	Date: 2009-11-04 Name: ***	Part Number: DBN-200	Title: Blower
			The drawings, AutoCAD, 3-D Models, and specifications are the property of Avani Environmental Intl. Inc. (AE) and may not be reproduced, distributed, modified, or otherwise used, except provided herein, without the express written permission of AE.		Size A	Scale 1 = 1
			Drawing Number: SDC-20-16MDF			

Reference Number	Description	Part Number	Quantity
7	Control Box for Blower and Motor	AVANI-SDC-20-16MDF-7	1

See appendix for wiring diagram.



AVANI Large Cartridge Collector

Reference Number	Description	Part Number	Quantity
8	Noise Reducer	AVANI-SDC-20-16MDF-8	1

<i>DO NOT SCALE</i>	<i>IF IN DOUBT ASK</i>		Revisions			
			Rev	Description	Date	Approved

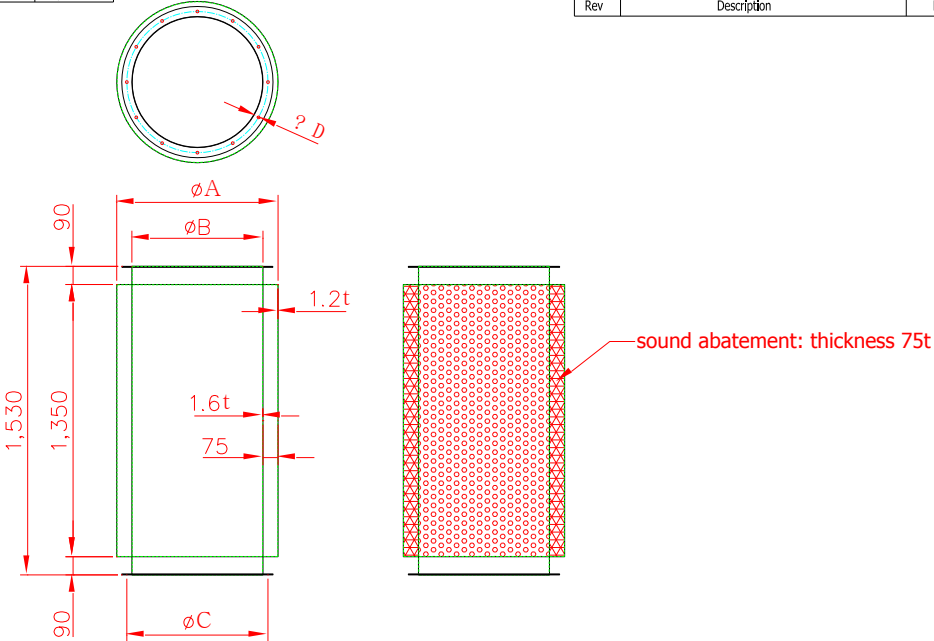

Noise Reducer / Silencer Size				
HP	A	B	C	D
20HP	$\phi 600$	$\phi 450$	$\phi 492$	$\phi 11 \times 12$ holes

AVANI ENVIRONMENTAL INTL. INC. Sales Department 95 Cypress Drive Youngsville, NC 27596 (919) 570-2862 info@avanienvironmental.com		Date	Name	Part Number:	Title:		
	Drawn by:	2009-08-25	***	SV-	Noise Reducer / Silencer		
	Checked by:						
The drawings, AutoCAD, 3-D Models, and specifications are the property of Avani Environmental Intl. Inc. (AE) and may not be reproduced, distributed, modified, or otherwise used, except provided herein, without the express written permission of AE.					Size A	Scale 1 = 1	Drawing Number: SV-



AVANI Large Cartridge Collector

Appendix 1 - Electrical Circuit Diagram

Main Electrical Components for SDC-20-16MDF Blower Control Box

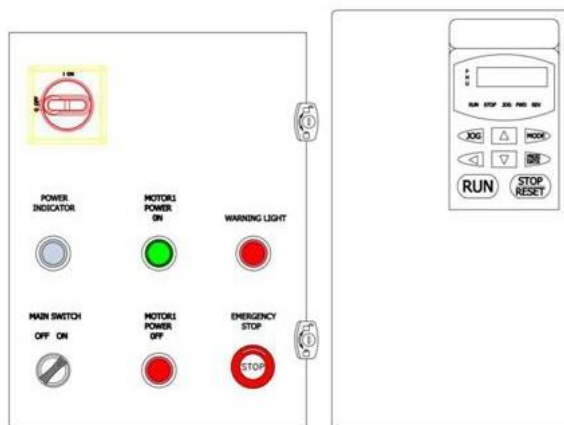

AVANI Large Cartridge Collector

Main Electrical Components for SDC-20-16MDF Blower Control Box

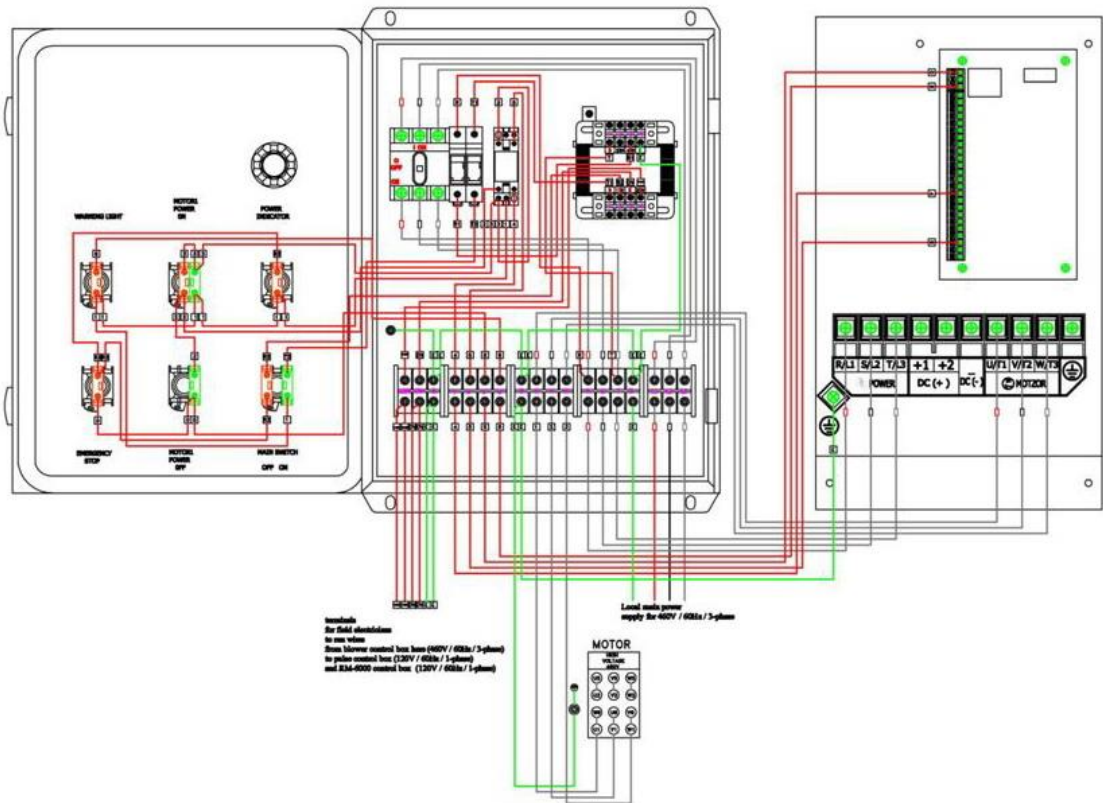

AVANI Large Cartridge Collector

Main Electrical Components for SDC-20-16MDF Blower Control Box

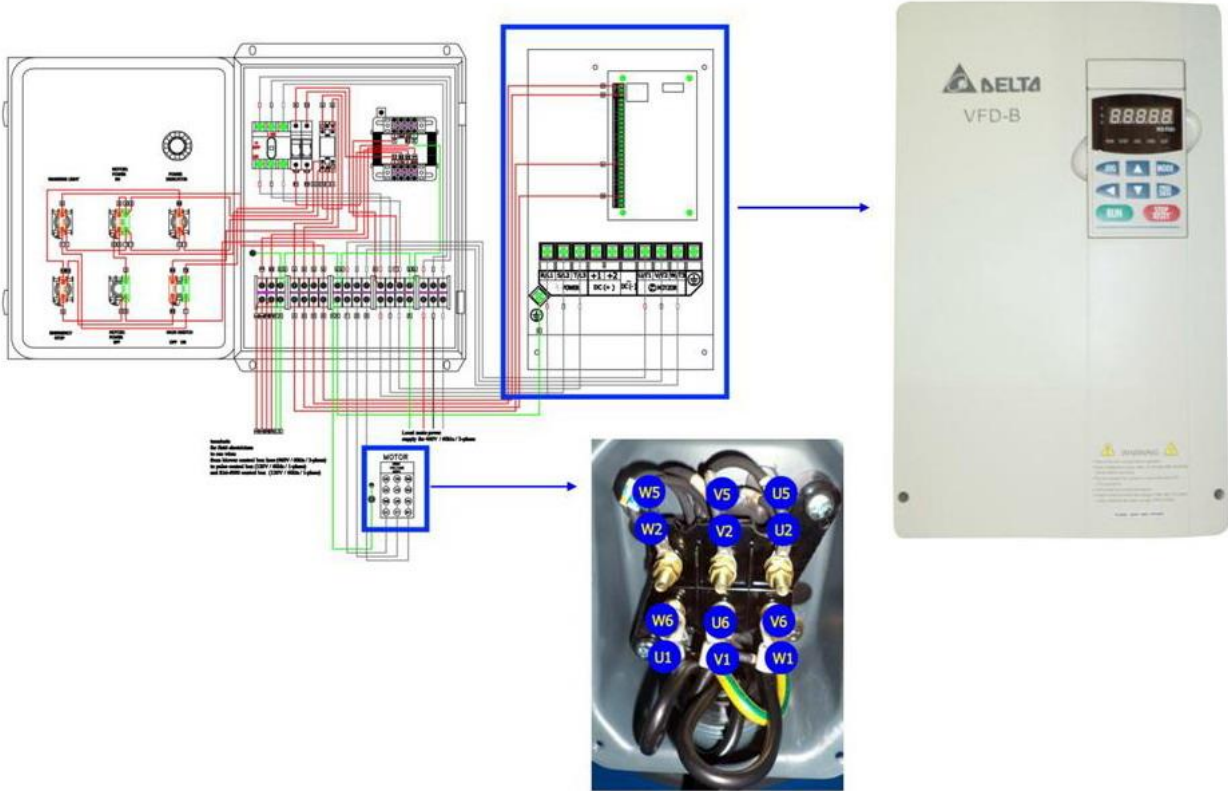

AVANI Large Cartridge Collector

Main Electrical Components for SDC-20-16MDF Blower Control Box



◆ Relay.



◆ Panel disconnect switch.



◆ Fuse bus.

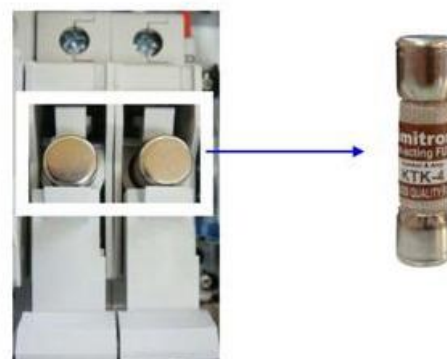

AVANI Large Cartridge Collector

Main Electrical Components for SDC-20-16MDF Blower Control Box



◆ Transformer for 460V.



◆ Connecting to the pulse control box.



◆ Connecting to the RM-6000 control box.



◆ Connecting to motor.



AVANI Large Cartridge Collector

Main Electrical Wiring for SDC-20-16MDF Pulse Control Box

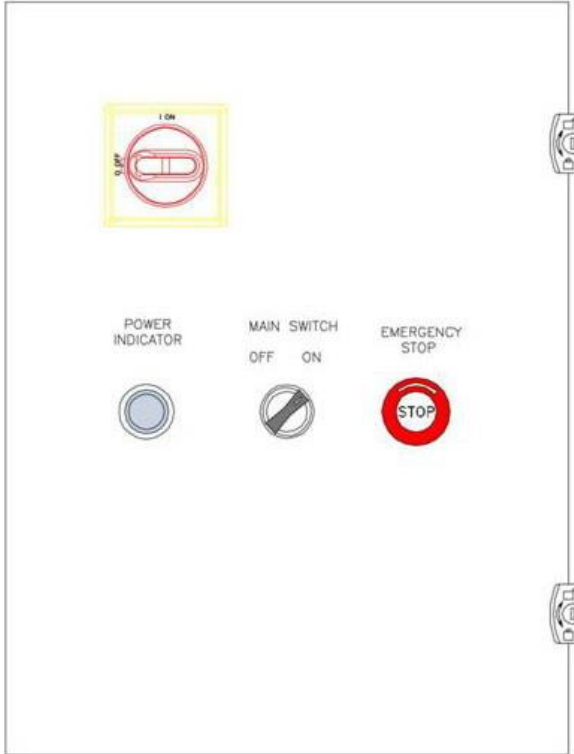

AVANI Large Cartridge Collector

Main Electrical Wiring for SDC-20-16MDF Pulse Control Box

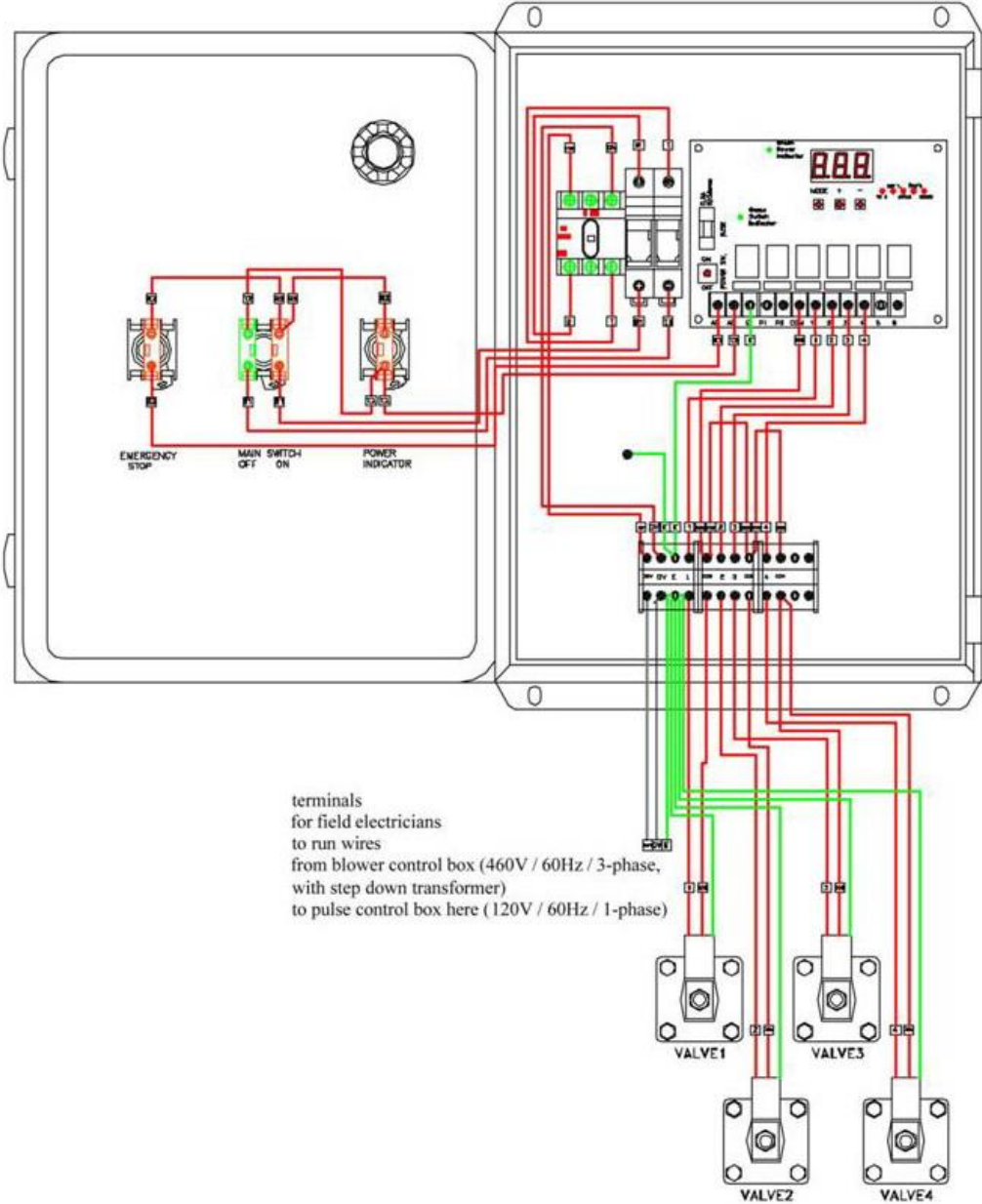

AVANI Large Cartridge Collector

Main Electrical Components for SDC-20-16MDF Pulse Control Box

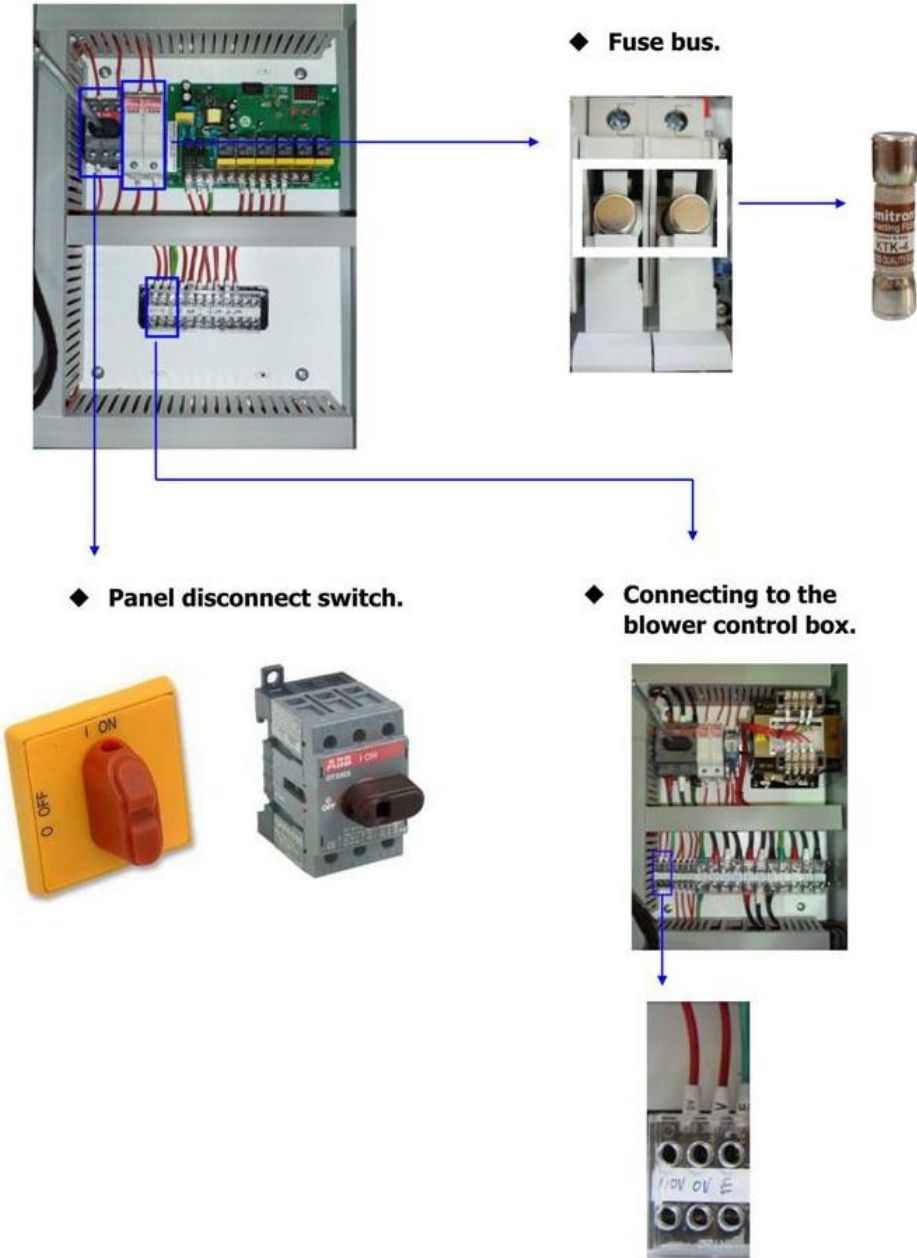

AVANI Large Cartridge Collector

Main Electrical Components for SDC-20-16MDF Pulse Control Box



◆ Sequential Controller (Front).



◆ Sequential Controller (Back).



AVANI Large Cartridge Collector

Main Electrical Components for SDC-20-16MDF Pulse Control Box

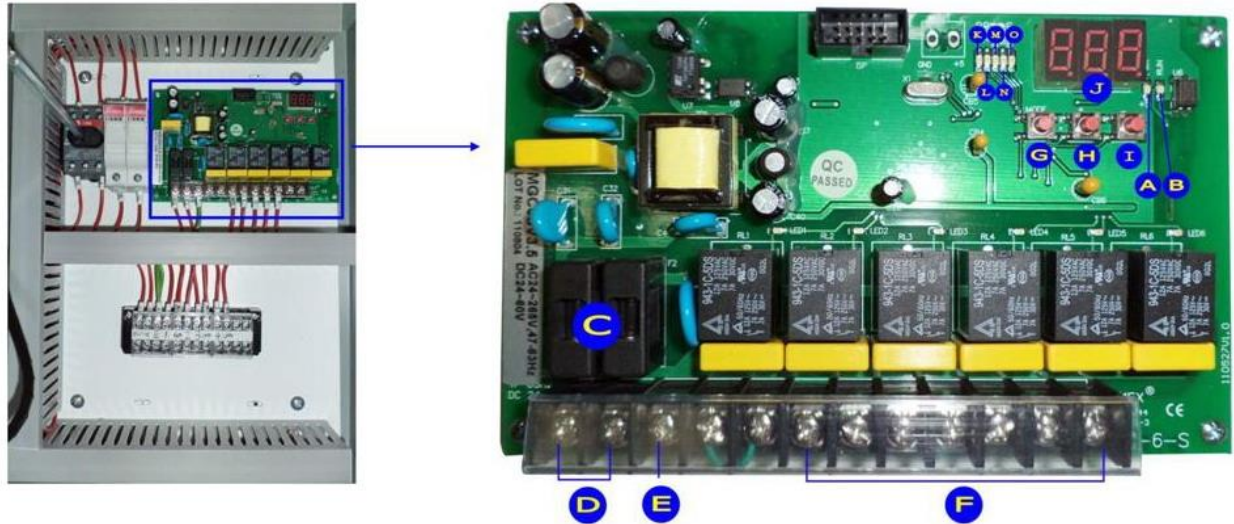

- ◆ A : Power Indicator.
- ◆ B : Power Indicator.
- ◆ C : Fuse.
- ◆ D : Power Terminal.
- ◆ E : Grounding.
- ◆ F : Valves.
- ◆ G : Mode.
- ◆ H : Digits Adding Button.
- ◆ I : Digits Decreased Button.
- ◆ J : Digits shown.
- ◆ K : Air Pulse Jet Sprayed Length.
- ◆ L : Pulse Jet Intervals.
- ◆ M : Number of Valves.
- ◆ N : Air Pulse Jet Cleanses Cartridges after Machine Stops Operation. (Preserved function).
- ◆ O : Settings completed.

AVANI Large Cartridge Collector

Main Electrical Components for SDC-20-16MDF Pulse Control Box



◆ Valve



AVANI Large Cartridge Collector

Contact Information

Avani Environmental Intl. Inc.
95 Cypress Drive,
Youngsville, NC 27596
Email: info@avanienvironmental.com
www.avanienvironmental.com

Customer Service: info@avanienvironmental.com
Tel: 919-570-2862 ext. 208

Engineering Service: engineering@avanienvironmental.com
Tel: 919-570-2862 ext. 203