



**Date:** June 01, 2012

**To:** Johnson Controls

**Project:**

**Attn:**

**Recommended Equipment:**

(1) SDC-10-8MDF Cartridge Collector Drawer Type w/ Feet (outside install)

- 4,400CFM @ 8" SP
- normal dia. 12.8" x 52"L polyester cartridges
- silencer

Louver A & C: 20"(W) by 36"(H)

Louver B: 36"(W) by 12"(H)

---

**Avani Environmental Intl. Inc.**  
95 Cypress Drive  
Youngsville, NC 27596  
[www.avanienvironmental.com](http://www.avanienvironmental.com)

Phone: (919) 570-2862  
Fax: (919) 570-2863  
Email: [info@avanienvironmental.com](mailto:info@avanienvironmental.com)  
[www.weldingbooths.com](http://www.weldingbooths.com)

The drawings, AutoCAD, 3-D Models, and specifications are the property of Avani Environmental Intl. Inc. (AE) and may not be reproduced, distributed, modified, or otherwise used, except provided herein, without the express written permission of AE.

DO NOT SCALE

IF IN DOUBT ASK



Revisions			
Rev	Description	Date	Approved

- SDC-10-8MDF SPECIFICATION -

### Blower Outlet

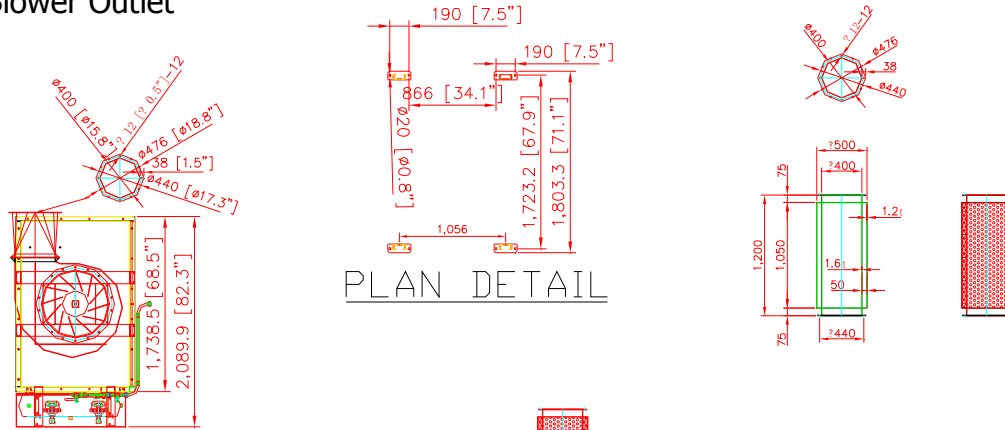

- Direct Drive Blower (on the machine top)
- Motor: 10HP x 1 pc
- CFM: 4,400 ft<sup>3</sup>/min @ 8" SP (460V / 60Hz / 3-phase)
- Include:
  - UL Individual Control Box for Cartridge Collector and Blower

- \*\*\*Cartridge Collector Inlet: 14"
- \*\*\*Blower Outlet: dia. 400mm (square to round transition made at dia. 15.8" for fan outlet provided).
- Cartridge Filter: Dia. 325mm x 1320mm x 8pcs (Dia. 12.8" x 52" x 8pcs)
- Material: Polyester with TEFLON coating.
- Filter Area: 19m<sup>2</sup> x 8 = 152m<sup>2</sup> (1635.52 ft<sup>2</sup>)
- Pleat Depth: 48mm

- Horizontal Positioned Filters,
- Continuous Welded Seams,
- Gasket and Latched Doors,
- Powder Coated Paint and
- Reverse Jet Pulse Cleaning
- Include:
  - Filter Chamber
  - Inlet Square Pipe (need dimensions)
  - Fan/motor combinations
- No. of Valves: 2
- Inlet Air: <sup>3</sup>/<sub>4</sub>"
- Compressed Air Requirement: 90 PSI
- Compressed Air Reservoir: 7.9 gallon
- Dimension: 46.3" x 81.9" x 163" (1176 x 2077.5 x 4136.8mm)
- Construction: 13 Gauge for panel; 11 Gauge Steel Cabinet
- Max. Operating Temp.: 120°C
- Paint Color: Blue

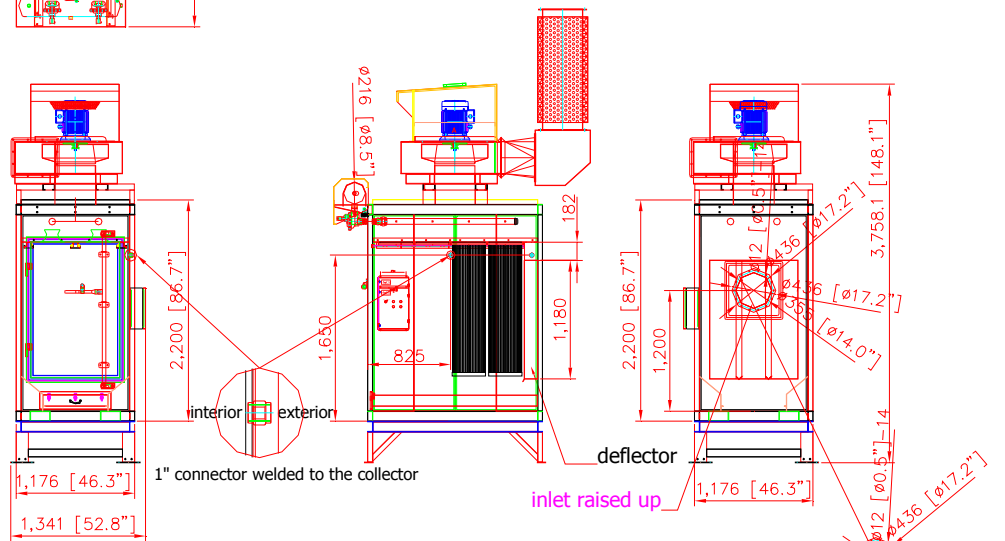

- \*\*\*1" connector welded to the right side of the collector.
- \*\*\*with Feet underneath the machine.
- \*\*\*pulse control box run off of 120V, 1-phase, no transformer inside pulse box. Pulse box located outside on the collector.
- \*\*\*blower control box: 460V / 60Hz / 3-phase, with transformer. Blower box located inside the building.
- \*\*\*w/ silencer (dia. 400mm x 1200mmL)\*\*\*

### Cartridge Collector Inlet

AVANI ENVIRONMENTAL INTL. INC. Sales Department  
 95 Cypress Drive (919) 570-2862  
 Youngsville, NC 27596 info@avanienvironmental.com

Drawn by:	Date	Name	Part Number:	Title:		
Checked by:	2011-10-14	***	SDC-10-8MDF	Cartridge Collector (drawer type) w Feet		
The drawings, AutoCAD, 3-D Models, and specifications are the property of Avani Environmental Intl. Inc. (AE) and may not be reproduced, distributed, modified, or otherwise used, except provided herein, without the express written permission of AE.				Size	Scale	Drawing Number:
				A	1 = 1	SVL-800-02



SDC-10-8MDF  
w/ silencer

SDC-10-8MDF (4,400CFM @ 8"SP)

(1) 10HP top mounted fan on (1) large 8  
cartridges collector (drawer type w/ feet,  
outside install)

Louver B

36" (W) by 12" (H)

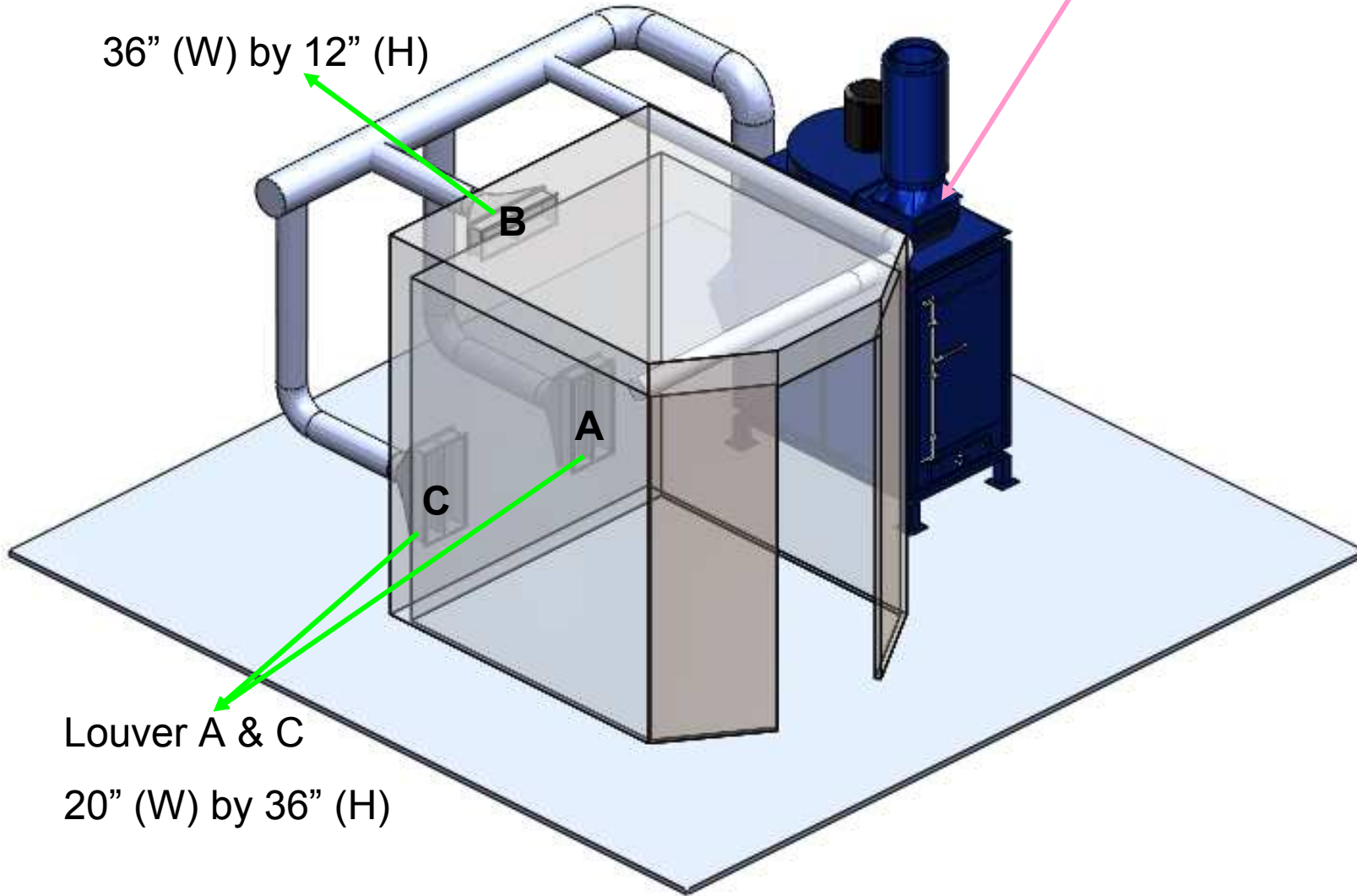

Louver A & C

20" (W) by 36" (H)

