

1. cable changed from 5mm to 6mm

2. add (3) 3/8" studs to prevent the cable from coming off from the wheel

3. lock washer and lock nut



lock nut

(3) 3/8" studs

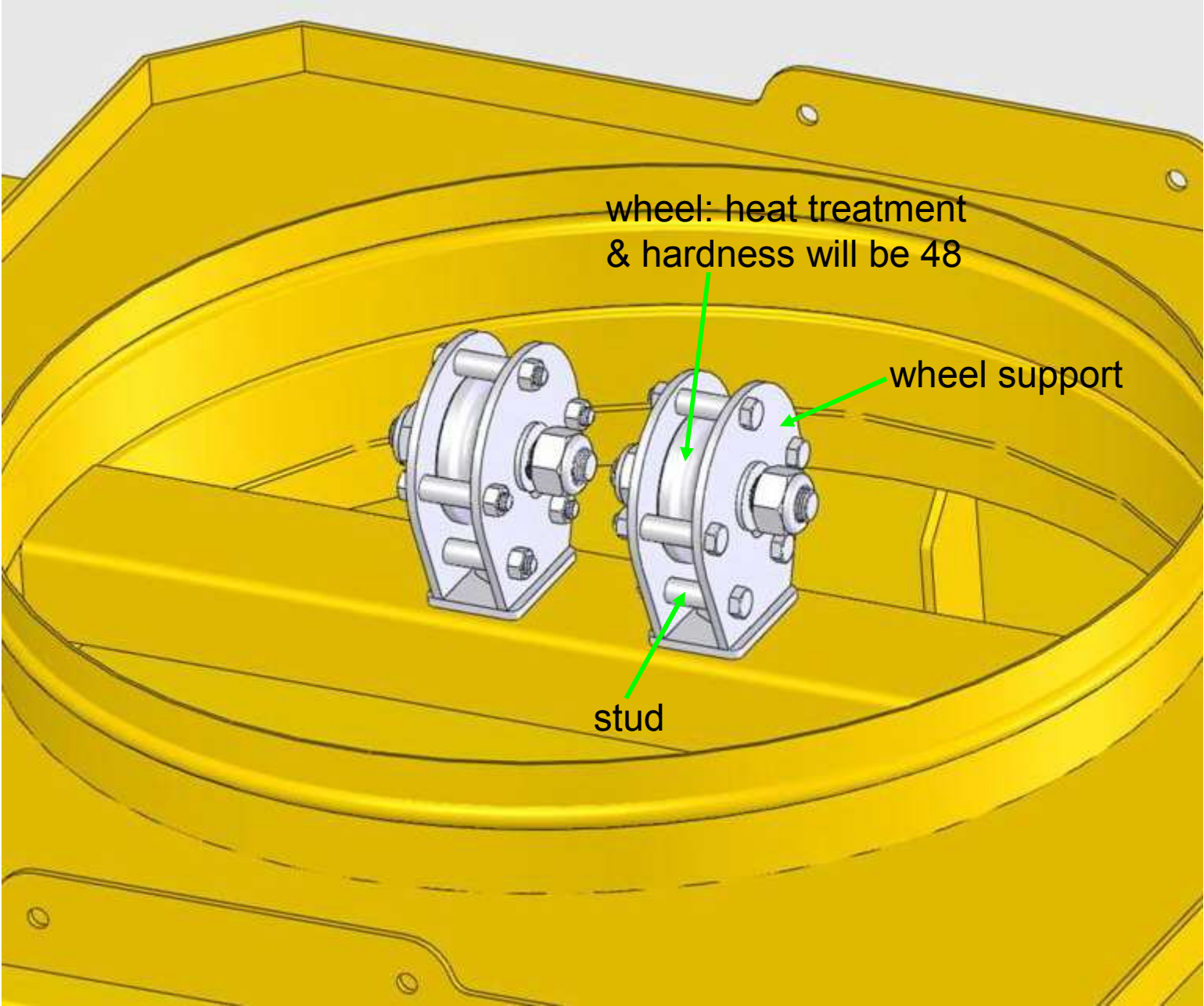

wheel: heat treatment
& hardness will be 48

wheel support

stud

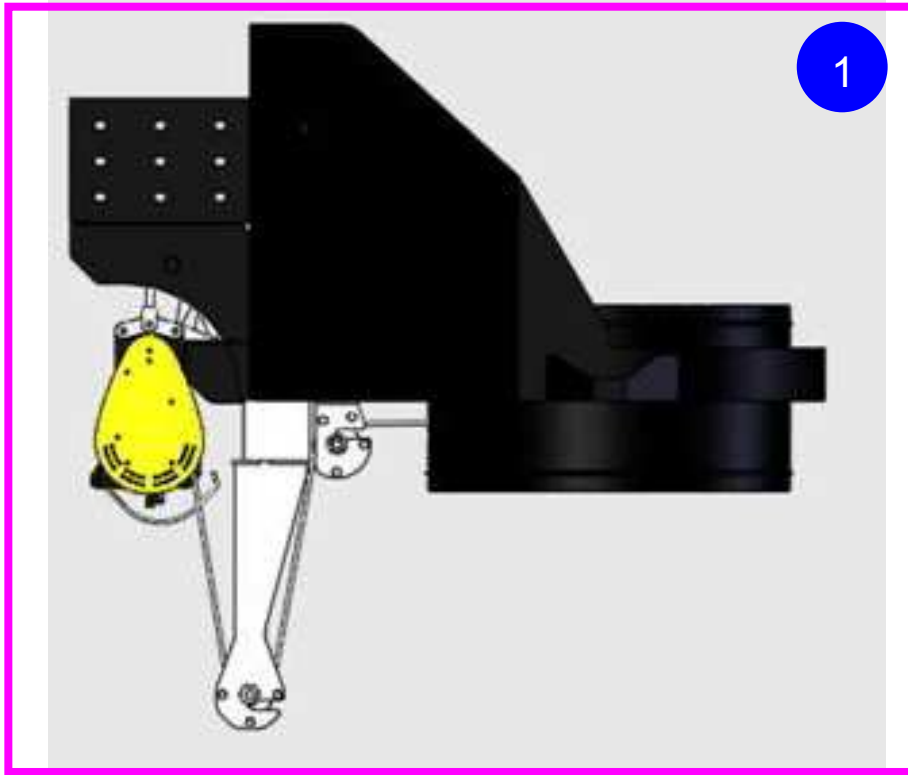

Will manufacture #1 and #2 to stimulate the situations of using the cables holding the hood and lowering it to hit something. Make sure that the cable will not come out of the wheels.

The test will be processed to run 24hrs a week. Afterwards, these parts will be sent out for local inspection to check if they are worn out or not.

