

BILL OF MATERIAL				
ITEM	DESCRIPTION	PART NO.	DWG NO.	MAT'L
1	BIN ASSEMBLY	537472		1
1	HOPPER ASSEMBLY	537473		2
1	TOP COVER ASSEMBLY	537474		3
2	(GAL.) ENAMEL-AVANI BLUE	536624		4
48	3/8"-16 x 1 1/4" LG WHIZ BOLTS	516038		5
48	3/8"-16 WHIZ NUTS	514934		6
1	SEALANT 3M-606	506977		7
2	LOGO STICKER			8
1	CONFINED SPACE STICKER			9
*	DRUM LID ADAPTER	500135		10
*	SLIDE GATE	504201		11
*	HARDWARE BAG	537455		12

537453 PART NO. \* SEPARATE LINE ITEM ON ORDER

**SCIENTIFIC MP-8 CARTRIDGE DUST COLLECTOR SPECIFICATIONS:**

- |                                 |                     |
|---------------------------------|---------------------|
| 1. NUMBER OF CARTRIDGES         | 8                   |
| 2. FILTER DIMENSIONS            |                     |
| LENGTH                          | 28"                 |
| DIAMETER                        | 14 1/8"             |
| 3. COMPRESSED AIR REQUIREMENTS  |                     |
| SCFM @ 90-100 PSIG.             | 1.1 - 4.5           |
| CLEAN DRY AIR                   |                     |
| 4. NUMBER OF VALVES             | 4 (1")              |
| 5. INLET, OPENING               | 12" x 20"           |
| 6. OUTLET, OPENING              | 17 3/4" DIA.        |
| 7. TWO ACCESS DOORS ON HOPPER   | 20" x 20"           |
| 8. HOPPER DISCHARGE             | 11 1/4" x 11 1/4"   |
| 9. NEMA 4 CONTROL PACKAGE       | 120 V. 1 PH. 60 HZ. |
| 10. HOUSING MATERIAL            | 12 GA. HRS          |
| 11. APPROXIMATE SHIPPING WEIGHT | 2000 LBS.           |

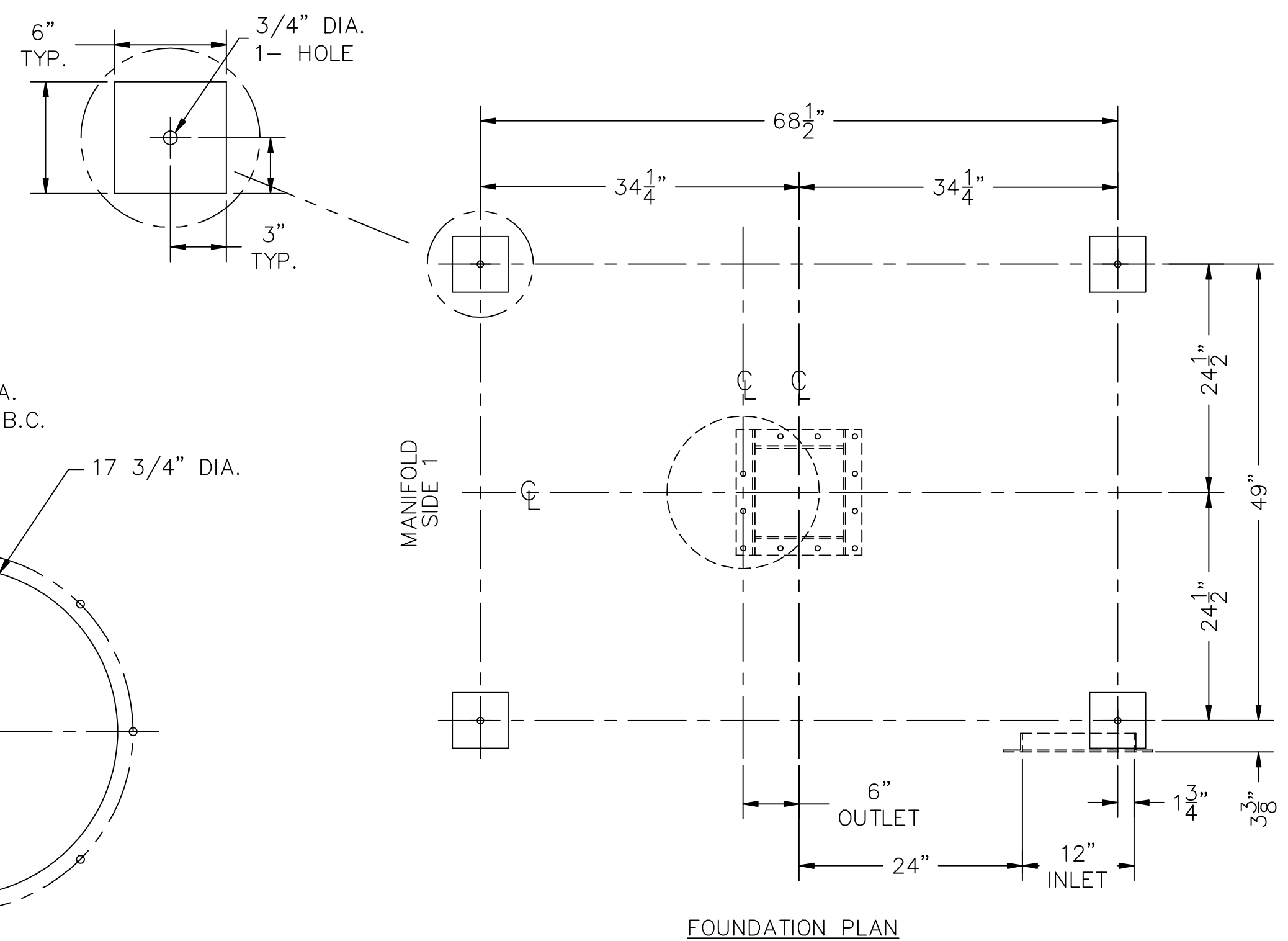
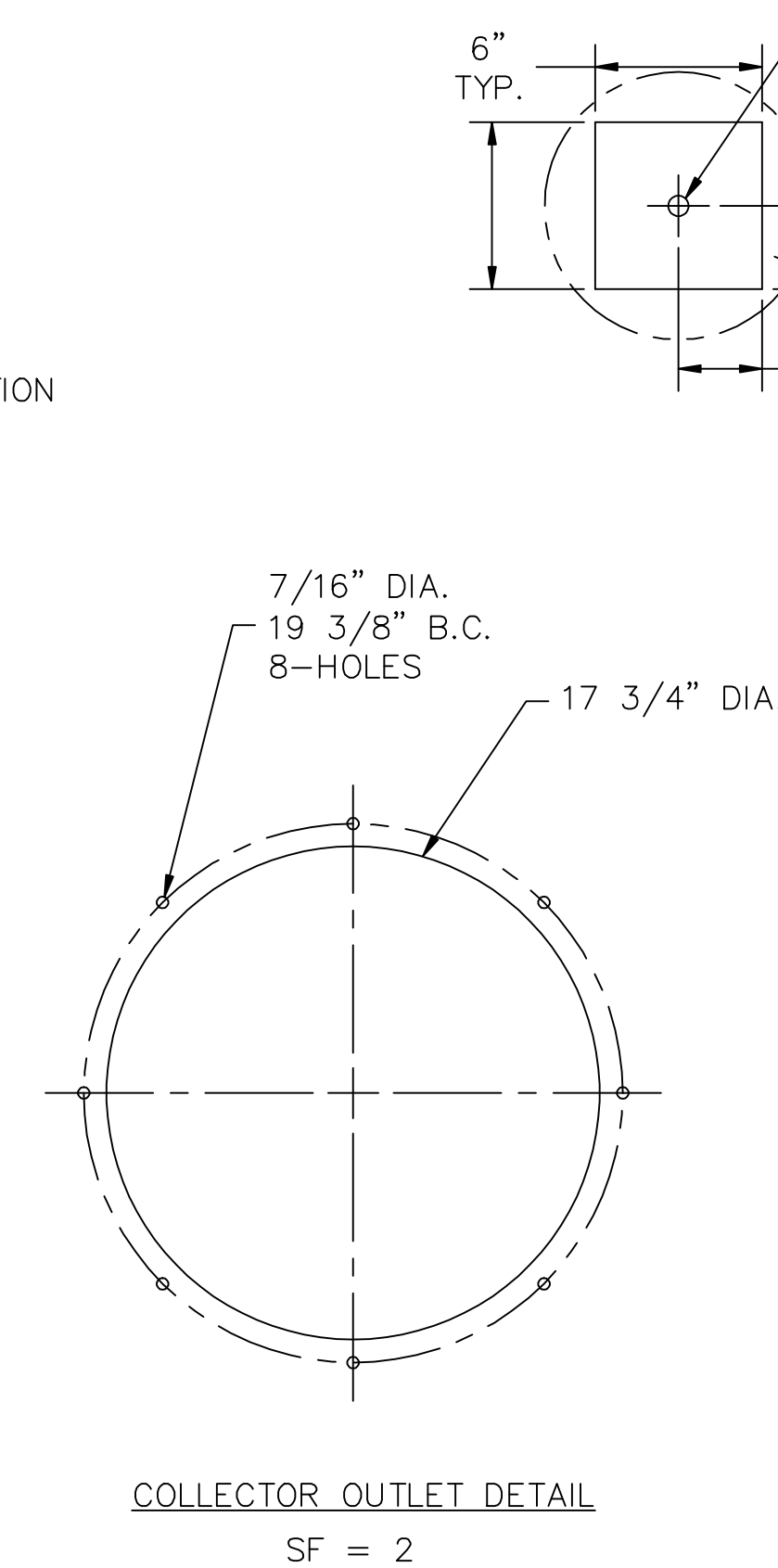
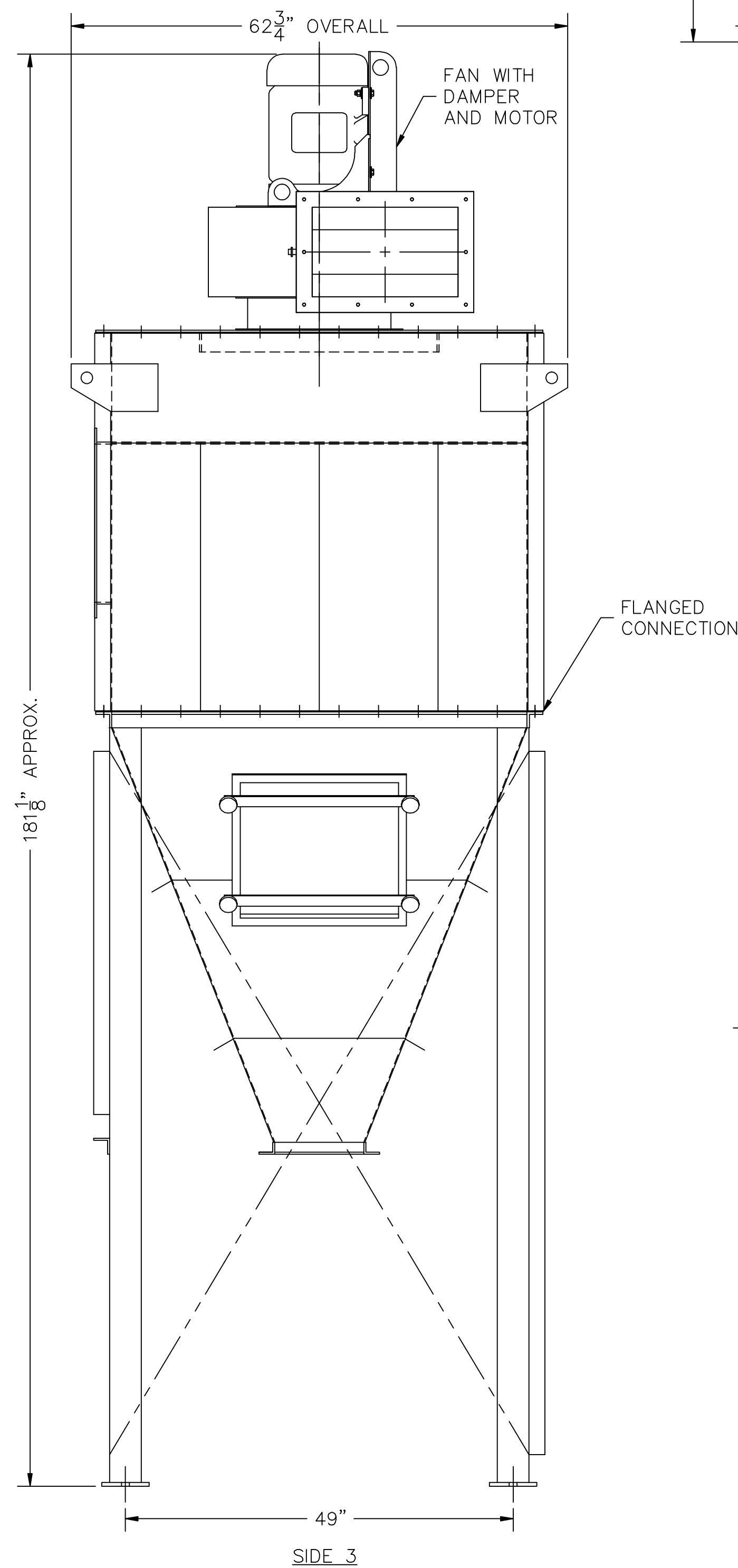
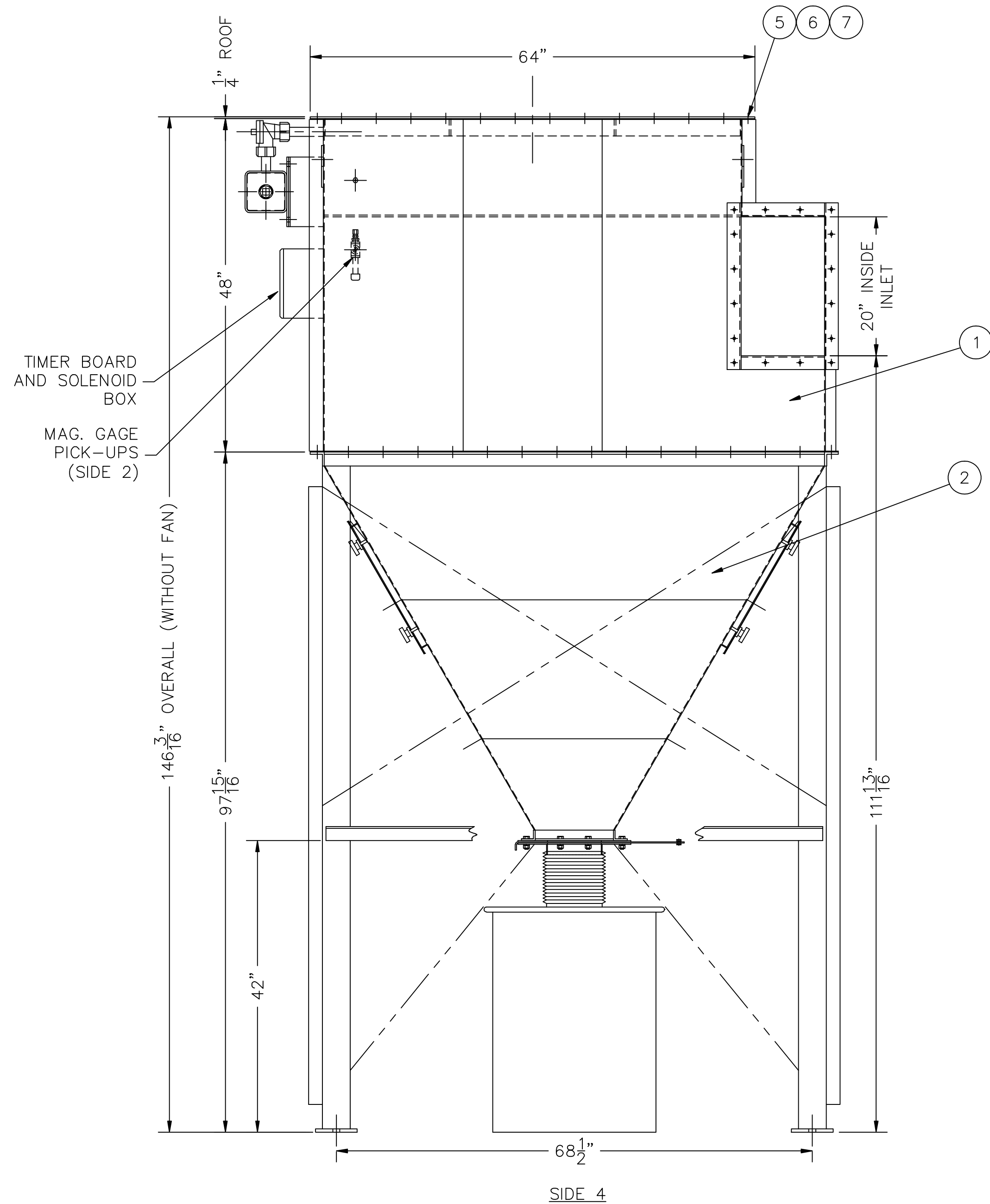

PLEASE SIGN APPROVED FOR MANUFACTURE: X \_\_\_\_\_ DATE: \_\_\_\_\_

**CERTIFIED PRINT**  
USE ONLY FOR

YOUR ORDER 4640  
OUR ORDER 64735  
CUST. AVANI ENVIRONMENTAL  
DATE 5/21/12

TOLERANCE UNLESS OTHERWISE NOTED .000 ± FRACTIONS ± 1/16" .00 ± ANGLES ± 1°		SCIENTIFIC DUST COLLECTORS 4101 W. 126th STREET ALSIP, ILLINOIS 60803 U.S.A.
DRN BY JLL	CHD BY DATE 5/25/12 SCALE 5/64"=1"	
REFER TO 62375, 62736, 63078		DRAWING NO. 64735
		REV. NO.

USE WIRING DIAGRAM W4-A

THIS MATERIAL IS PROPERTY OF SCIENTIFIC DUST COLLECTORS. NO RIGHTS ARE GRANTED TO USE SUCH MATERIAL FOR ANY PURPOSE OTHER THAN (1) PRODUCT EVALUATION OR MAINTENANCE OR (2) THE FURNISHING OF SERVICES AND SUPPLIES TO SCIENTIFIC DUST COLLECTORS.