

AVANI Welding Station



Customer:	Harlingen High School		
Customer PO#:			
AVANI SO#:		Tested By:	
Serial #:	121301 ~ 121312		
Ship Date / Install Date:			

Please read and save these instructions. Read carefully before attempting to assemble, install, operate or maintain the product described. Protect yourself and others by observing all safety information. Failure to comply with instructions could result in personal injury and/or property damage! Retain instructions for future reference.

avani
environmental

SMT-20120329



AVANI Welding Station

General Safety Information

MACHINE WARNING SIGNS

▲ DANGER

Indicates an imminently hazardous situation which, if not avoided, will result in death or serious injury.

▲ WARNING

Indicates a potentially hazardous situation which, if not avoided, could result in death or serious injury.

▲ CAUTION

Indicates a potentially hazardous situation which, if not avoided, may result in minor or moderate injury.

Used without the safety alert symbol (▲) indicates potentially hazardous situation which, if not avoided, may result in property damage.



Warning of electric shock



Do not expose the equipment to rain or use in damp locations.



Figure 1



Do not use the equipment around flammable products, if not avoided, sparks can ignite vapors from flammable products. Read and understand all warnings and operating instructions before using this equipment. Failure to follow all instructions may result in electric shock, fire, and/or serious personal injury or property damage.



Please read and save these instructions. Read carefully before attempting to assemble, install, operate or maintain the product described. Protect yourself and others by observing all safety information. Failure to comply with instructions could result in personal injury and/or property damage! Retain instructions for future reference.

avani
environmental

SMT-20120329



AVANI Welding Station

TABLE OF CONTENT

MACHINE WARNING SIGNS.....	2
Specifications.....	3
ADDITIONAL WELDING STATION SAFETY RULES.....	6
Assembly.....	7
Installation.....	7
ELECTRICAL INSTALLATION.....	7
Operation.....	8
Dimensions (in mm/inches).....	
Assembly Hardware.....	12
Filters.....	23
Filter Assembly.....	24
Repair Parts Illustration.....	27
Repair Parts List.....	28
Control Panel Explanation.....	34
Accumulated Function:.....	34
Pulse Cleaning Setting:.....	35
Appendix 1 - Electrical Circuit Diagram.....	36
Contact Information.....	50

Specifications

Motor.....	5HP
.....	460V / 60Hz / 3Ph
Air Volume (C.F.M.).....	2340 Ft ³ /Min (66.3 M ³ /Min)
Filtration Stages.....	1st – aluminum mesh x (2) pcs per station; total (4) pcs

Please read and save these instructions. Read carefully before attempting to assemble, install, operate or maintain the product described. Protect yourself and others by observing all safety information. Failure to comply with instructions could result in personal injury and/or property damage! Retain instructions for future reference.

avani
environmental

SMT-20120329



AVANI Welding Station

..... 2nd – aluminum mesh x (2) pcs per collector

..... 3rd – cartridge filter x (4) pcs per collector

Dimension (L x W x H) 116" x 64.9" x 131.8" (294.64 x 164.8 x 334.4 cm)

AVANI Welding Station

General Safety Information

(Continued)

⚠ WARNING

*Use this product
carefully to*

*effectively avoid any possible danger.
Observe the following safety
regulations to avoid bodily injury due
to electrocution during use.*

Read this Manual carefully before operating the product and preserve the Operation Manual properly.

1. Keep work area clean and organized.
 - A disorderly working environment will cause inconvenience and danger during operation.
2. Check if the working environment is suitable for using the product.
 - Do not use the product in a humid environment.
 - Use the product in a good working environment to reduce risks.
 - Do not use the product in a flammable gas or liquid environment to avoid danger.
3. Keep other persons away from the product, except for the operator, to avoid danger.
 - Do not let children get close to the product. All wires used by the product shall be in a safe location to prevent children from touching them.
4. All tools shall be safely stored.
 - When the tools are not used, please store them in a dry place safely beyond the reach and access of children.
5. If the machine breaks down, contact a service technician. Do not attempt to repair and possibly damage the machine.
6. When using the product, be sure to put on a welding suit and mask.
7. Use the electrical wires correctly.
 - During use, do not drag the electrical wires forcefully. Do not use these wires if fraying or current leakage occurs to avoid injury to the operator.
8. Before replacing parts, shut off power to the machine.
 - Check that the switch is in "on" or "off" position. Do not attempt the replacement when the machine is

Please read and save these instructions. Read carefully before attempting to assemble, install, operate or maintain the product described. Protect yourself and others by observing all safety information. Failure to comply with instructions could result in personal injury and/or property damage! Retain instructions for future reference.

avani
environmental

SMT-20120329



AVANI Welding Station

running. To replace parts or filter material, make certain that the switch is "off".

9. Use the power cord correctly. The total length of power cord shall not exceed 10 feet to avoid low power due to a drop in voltage and to prevent a possible hazard.

▲WARNING

When connecting the product, always follow the instructions in the Operation Manual to avoid injuries.

10. Care and Maintenance:

- Confirm that the parts/accessories have been fully assembled and will not adversely affect the machine operation.
- Check if the machine is operated properly.
- Replace damaged parts or accessories according to the instructions of the Manual. If the said instructions are not specified in the Manual, have a professional technician carry out the maintenance or replacement.
- Check that the electrical specifications of this machine meet safety requirements, and that the maintenance is carried out by a

professional technician. Use original manufacturer's parts and accessories to avoid injury.

- If a problem occurs, contact your dealer immediately.

ADDITIONAL WELDING STATION SAFETY RULES

The Welding Station can be dangerous if it is operated incorrectly. Therefore, the product must be used cautiously to avoid causing a hazard or damage. Unnecessary injuries may occur by failing to follow the instructions of the Safety Rules Manual. Be sure to put on protection equipment or suit that can protect your body, such as helmet and eye mask to avoid injuries from occurring. If any doubts or any unfitness occurs during use, be sure to stop the operation immediately. Keep in mind that the user shall be liable for using according to the specified safety rules and for operating the machine correctly.

1. Read this Manual carefully before operating the product.
2. Be sure to follow local electrical and safety regulations and observe the electrical safety standards practiced in the relevant area. All electrical wire

AVANI Welding Station

- connections and installation shall be carried out by a professional technician.
3. Do not operate the product near flammable materials, as sparks may ignite these materials and cause an explosion. Please confirm there aren't any flammables near the working site to avoid hazard.
 4. This product is suitable for collecting smoke and welding oil gas. Do not use it in collecting iron chips and dust at the same time to avoid producing sparks.
 5. Before replacement of parts or filter materials, be certain that the switch is disconnected.
 6. Do not kink the power cord and keep it away from oil, chemicals or flammables.
 7. Check that the voltage, phase count and grounding wire match the machine requirements.
 8. When the fan blades are operated at high speed, do not reach hand near these blades to prevent finger from breaking or clothes/necktie from getting caught. Do not put the hand or foreign matter into the air inlet to avoid getting caught in the high-speed rotation of fan blades.

9. When not in use, all air inlets of Welding Smoke Treatment Machine shall be covered.

Assembly



Do not connect the Welding Smoke

Treatment Machine before the assembly is finished and you have read and understood all of the precautions stated in the Manual.

NOTE: For correct assembly, refer to the Illustrations and Parts List on pages 26-32.

Installation

MOVING AND TRANSPORTATION

It CANNOT be handled and transported without the help of lifting tools. For your safety, read all instructions carefully.

Do not move without the help of others



to avoid causing danger.

ELECTRICAL INSTALLATION

POWER CONNECTION

1. Confirm that the power is properly connected under normal power supply condition. It is recommended to provide manual shutdown device before connecting power.

AVANI Welding Station

- It is recommended to protect the control equipment with suitable grade of fuse, and the length of fuse and power cord shall not be over 10 feet.

SHUTDOWN

- Disconnect power by manual method.
- When stopping operation, check if the switch is under off status.

EARTHING WIRE

Connect yellow/green wires to the earthing wire power jack. Confirm that the earthing wire has been properly connected before connecting main power cord to the machine at all times.

▲WARNING

Do not disconnect the wiring jack

before cutting off power!

POWER INSTALLATION AND STORAGE

The electrical power is configured as following. If conditions are beyond the scope stated below, then it is required to ensure that the power is well arranged and safe.

- Ambient temperature: Between 41°F and 131°F. If the time is over 24 hours, then the ambient average temperature shall not be over 122°F.
- Humidity: Between 30% and 95%
- Altitude: 3,280 feet

- Moving and Storing: -13°F to 131°F. For short-time storage (less than 24 hours), the storage temperature can be up to 158°F.

Operation

PRIOR TO START UP

Purpose: The Welding Station is specially suitable for treating the smoke generated during ordinary welding processing work, which can effectively collect and screen the smoke resulting from the welding work in maintaining the air quality of the working environment.

- Before starting the machine, be sure to read this Manual carefully.
- Before starting the machine, check if relevant safety protection measures have been taken according to the Manual.
- Before starting the machine, watch the motor turning direction according to the instruction of arrow direction.

START UP

- To ensure satisfactory performance for the Welding Smoke Treatment Machine, please confirm the air volume, power and the matching table of the Welding

AVANI Welding Station

Smoke Treatment Machine.

2. Connect power according to electrical installation procedure after installing the Welding Smoke Treatment Machine and the table. Disconnect power according to electrical installation procedure when the machine is not used.
3. The Welding Smoke Treatment Machine shall be turned on and off by pushing I/O button. Under normal operation status, use such I/O button.

Unpacking

The machine should be unpacked carefully. Check if the machine and components are consistent with those indicated in the Parts List. If any doubt arises or when the components are incomplete, contact your dealer.

Filter Cleaning / Preventive Maintenance

- Attached compressed air to the unit for cleaning purposes, at a source pressure of 90 PSI. The connection point is accessed by removing the panel on the side of the unit where the PSI label is in place and requires a 1/4" NPT fitting. A regulator must be incorporated in line to set pressure. Do not exceed 90 PSI pressure.
- Refer to control panel for initiating power to the motor and subsequent vacuum from the unit.
- During operation, the pressure gauge should maintain a reading of 4" WIC pressure or less.
- If pressure exceeds 4" WIC, or you experience a reduction in vacuum, proceed with the following action(s)
 - Turn Power off to the unit and push the pulse cleaning button. Allow the pressure to rebuild and push the button again. This procedure should be followed prior to every startup with the power off.
 - Adjust cleaning frequency via the timer board by increasing the frequency of pulses.
- If pressure exceeds 4" WIC with the collector at maximum cleaning frequency:
 - Remove the metal filter if

AVANI Welding Station

applicable and clean with water and re-install.

- If pressure exceeds 4" WIC after cleaning the metal filter:
 - Contact Avani for filter replacement (see contact information in this manual)

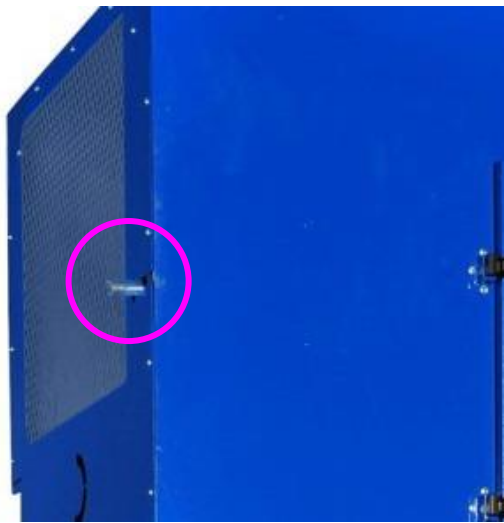

AVANI Welding Station

Dimensions (in mm/inches)

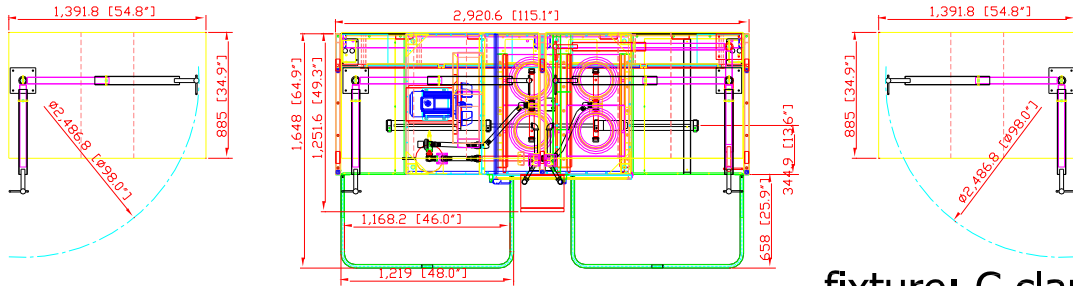

fixture: C clamp

control box with transformer
to step 460V down to 120V
to run lights & 120V outlets

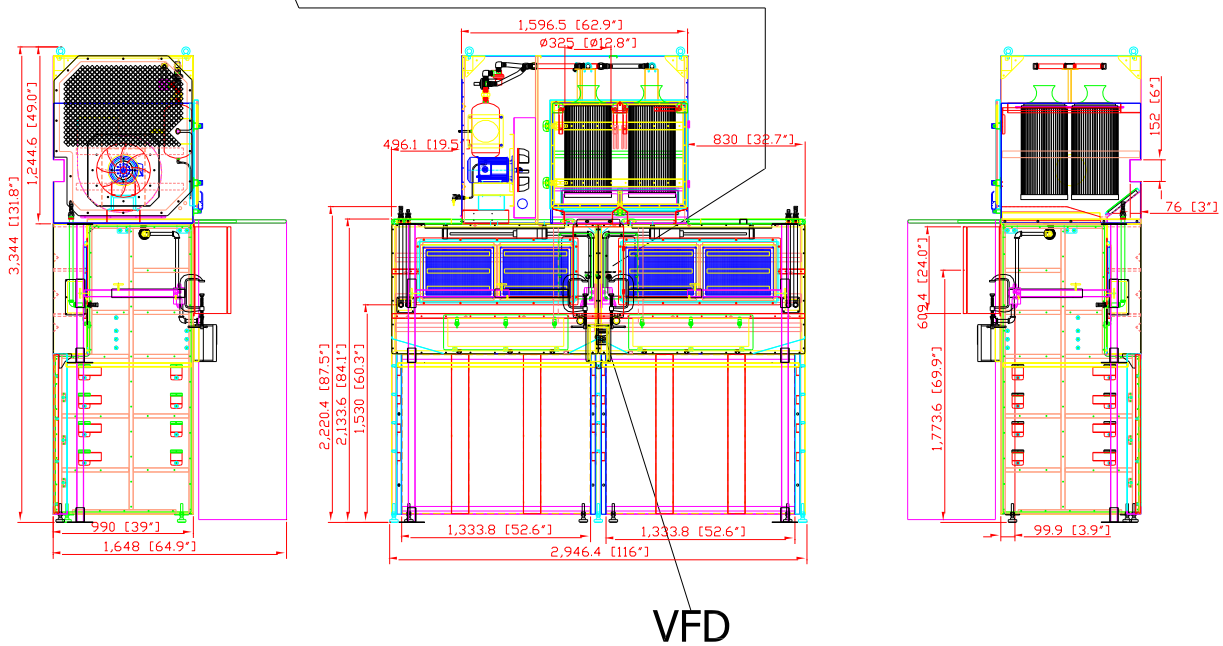

AVANI Welding Station

Assembly Hardware

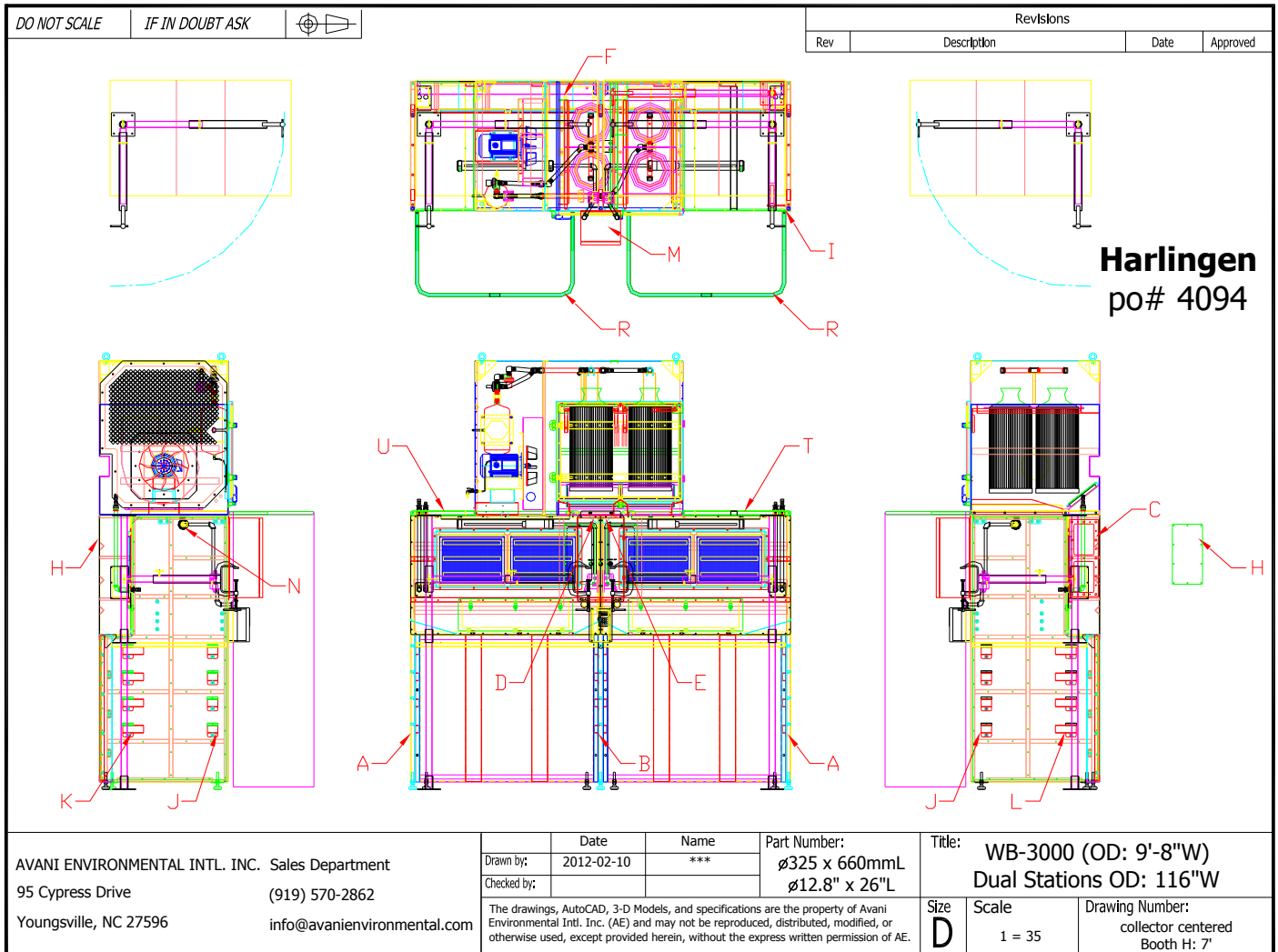

AVANI Welding Station

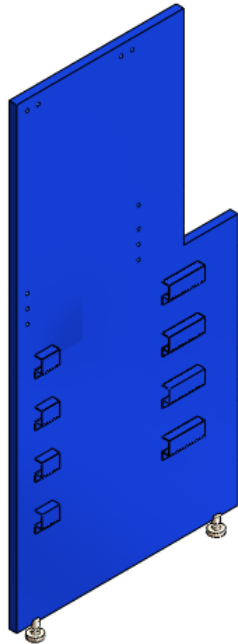

1.

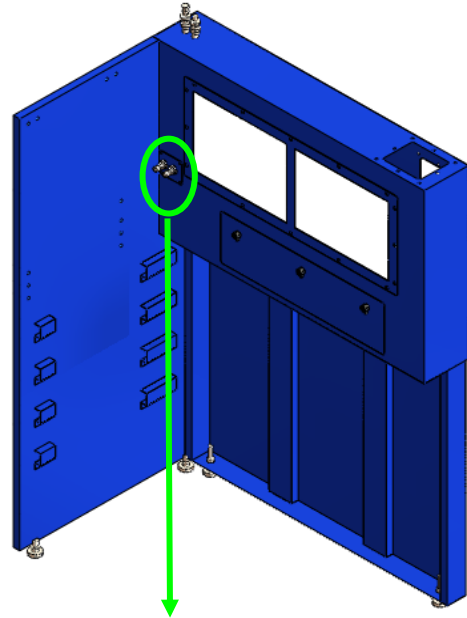

3. CO2 and air compressor connector.

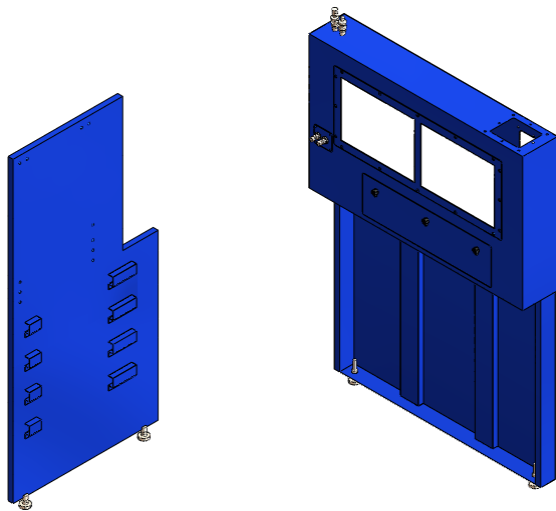

2. Left side panel to the main set.

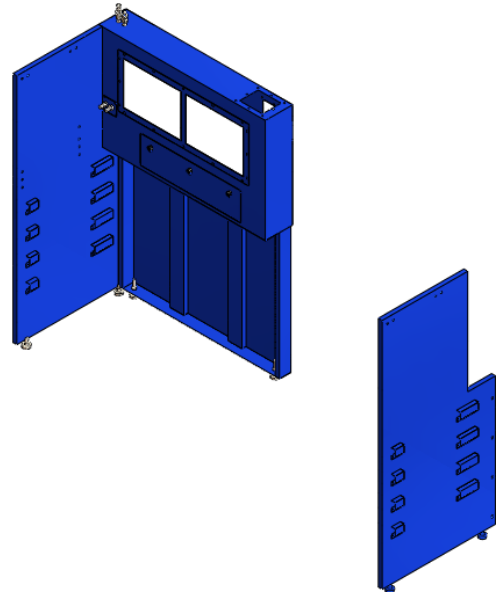

4. Middle panel to the main set.

AVANI Welding Station

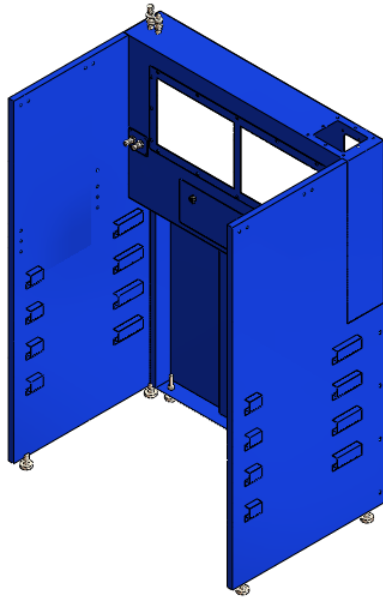

5.

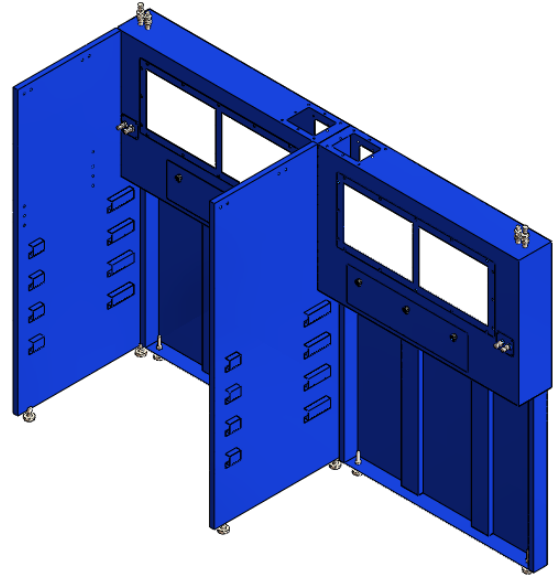

7.

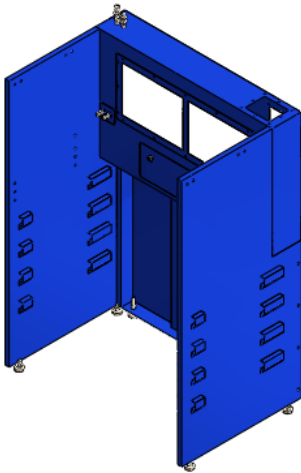

6. Fasten the right backdraft module to the middle panel.

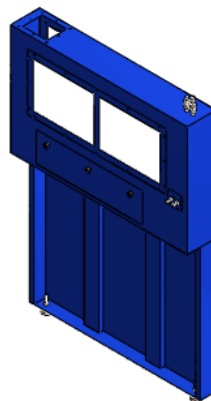

8. Right side panel to the main set.

AVANI Welding Station

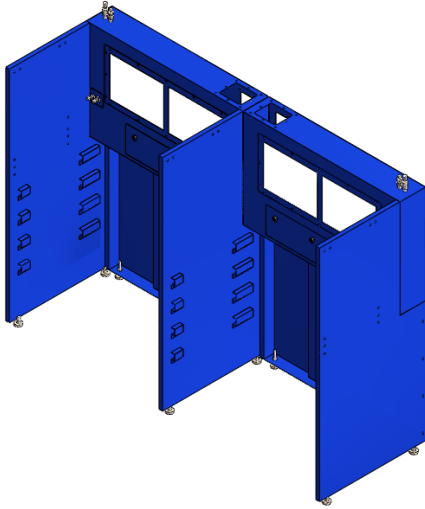

9.

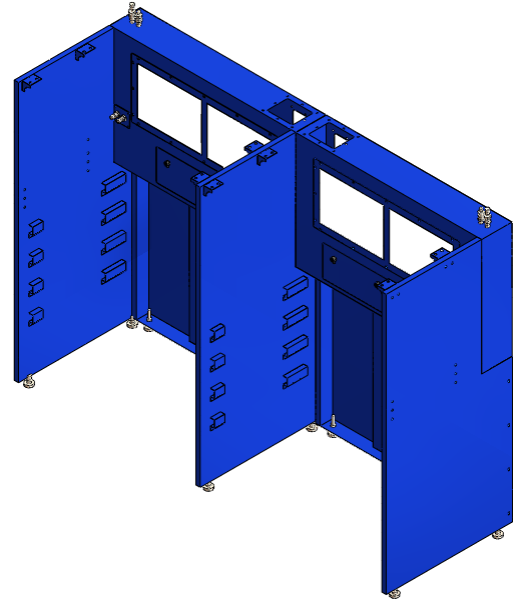

11.

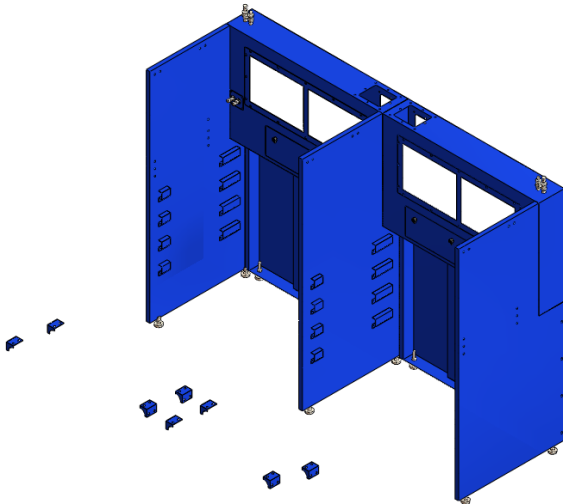

10. Attach the hypotenuse corner gussets bases at the panels, below the top hood draft, 2 pcs on each panel side, total 8 pcs for the two booths sitting together.

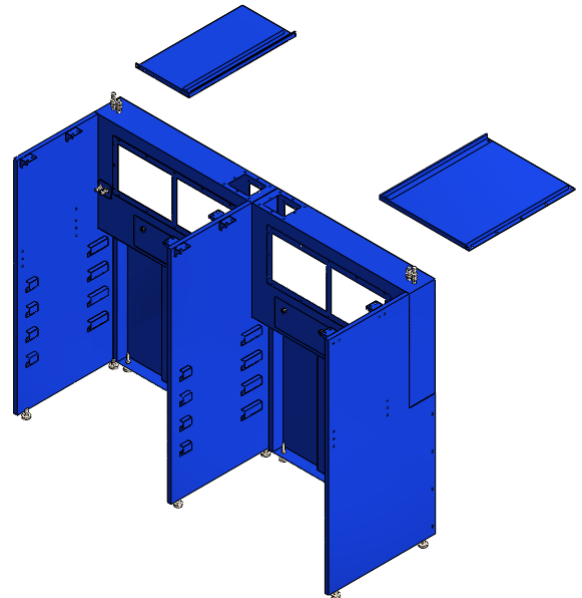

12. Secure the top hoods.

AVANI Welding Station

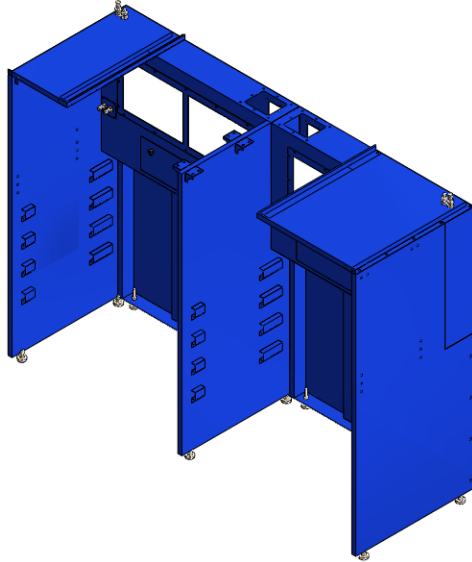

13.

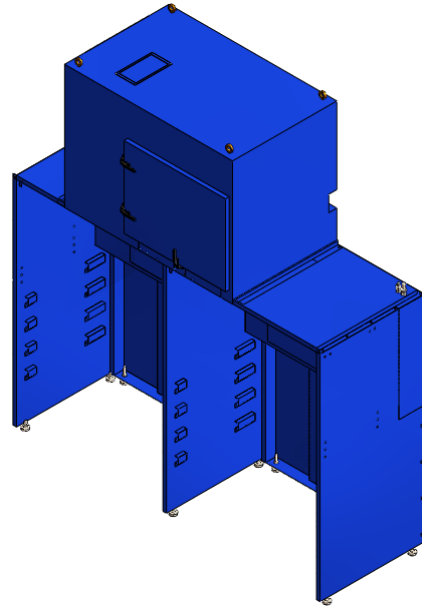

15.

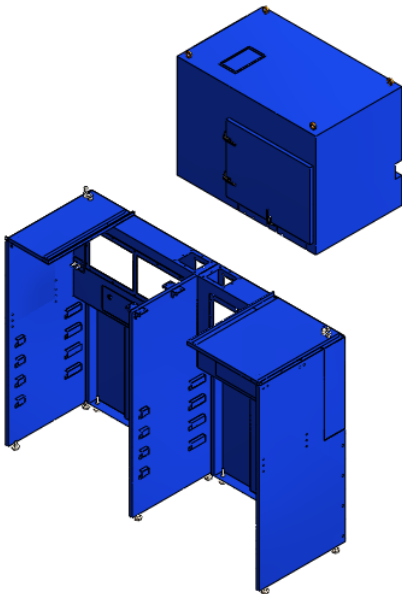

14. Place the top mount collector above the booths.

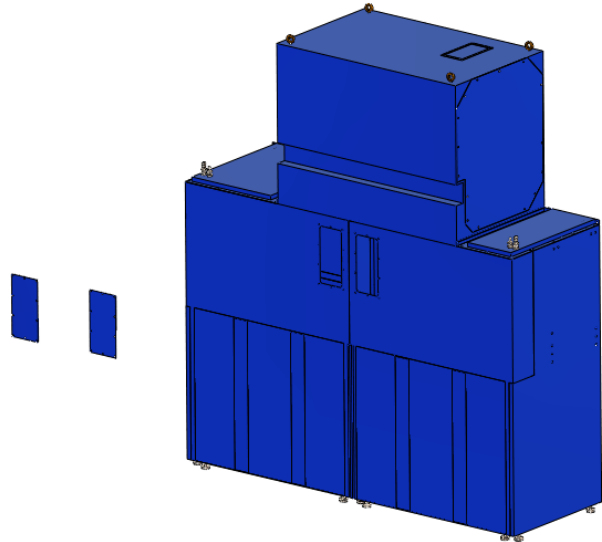

16. Seal boards for left and right backdraft modules.

AVANI Welding Station

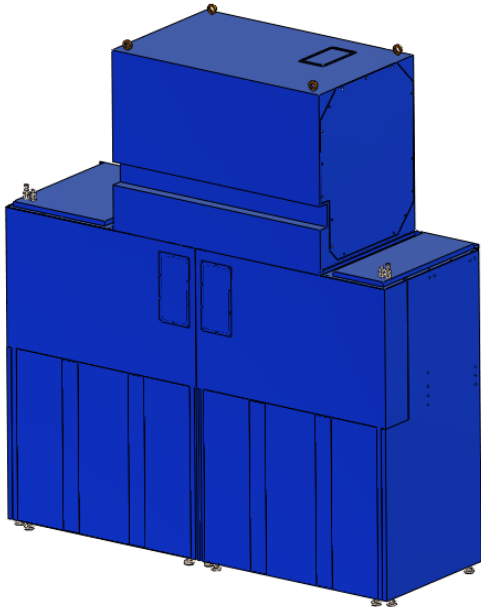

17.

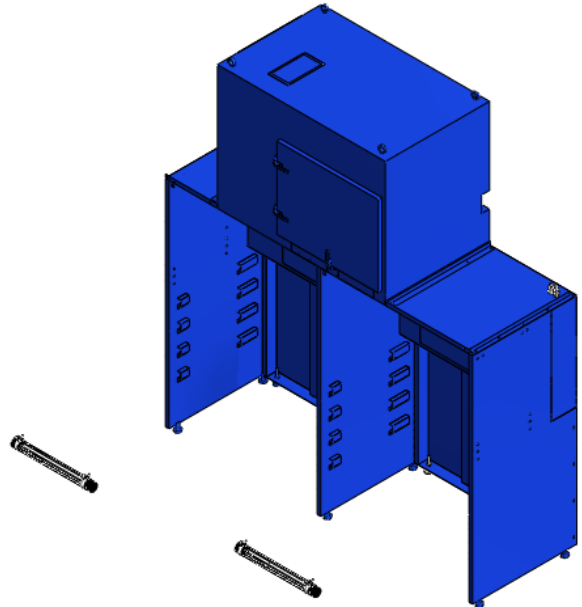

19. Install overhead lights.

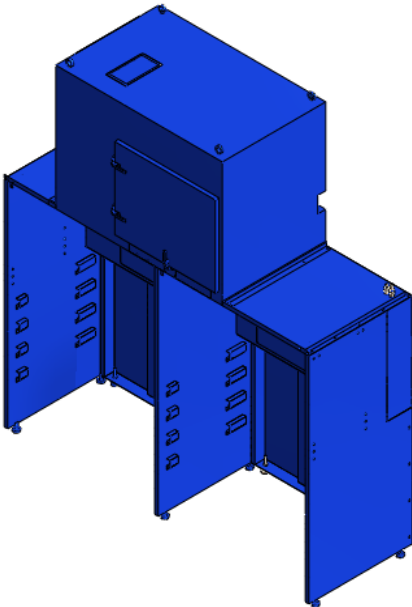

18.

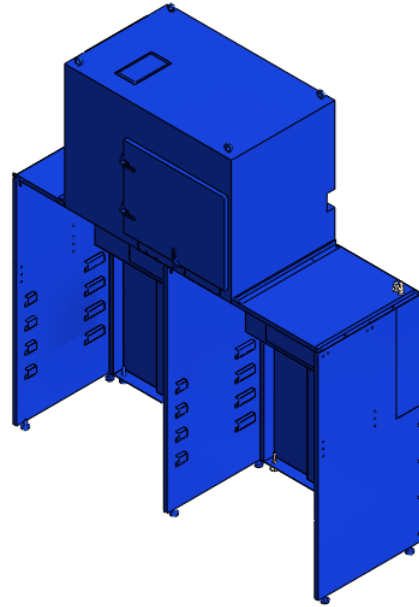

20.

AVANI Welding Station

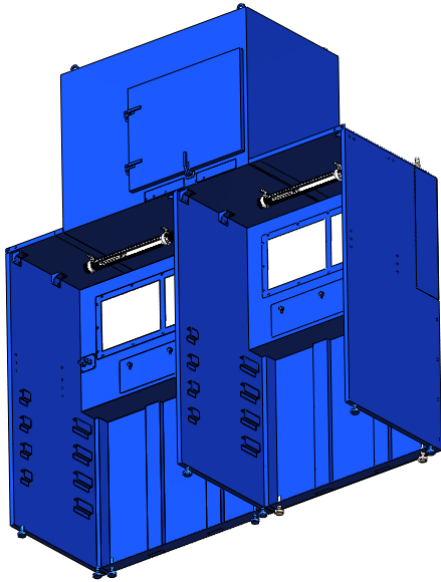

21.

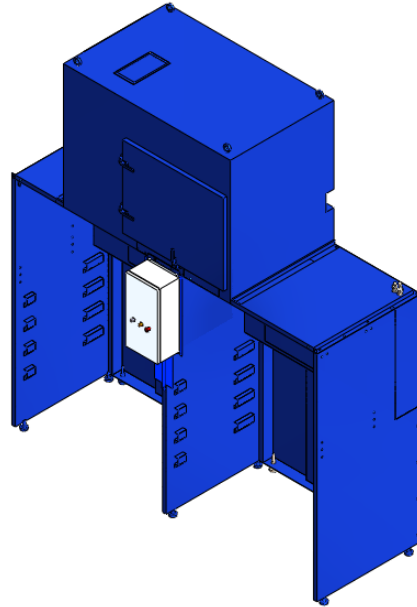

23.

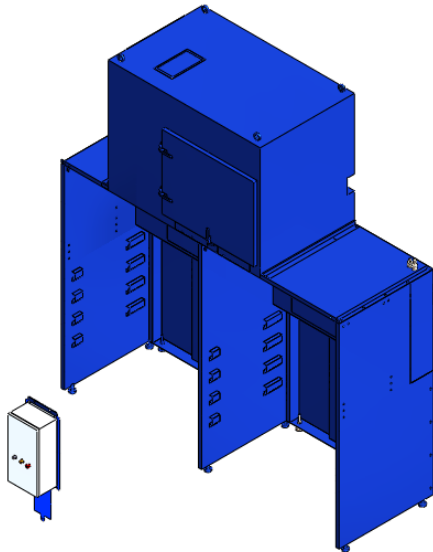

22. Secure the control box.

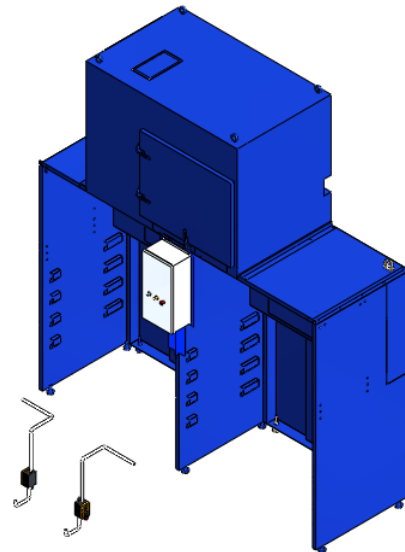

24. Equip the light switch and light conduit.

AVANI Welding Station

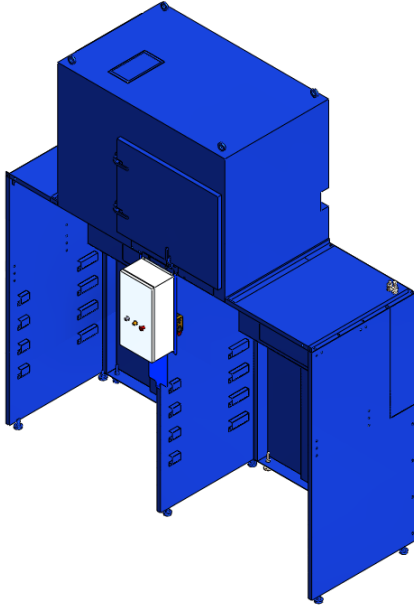

25.

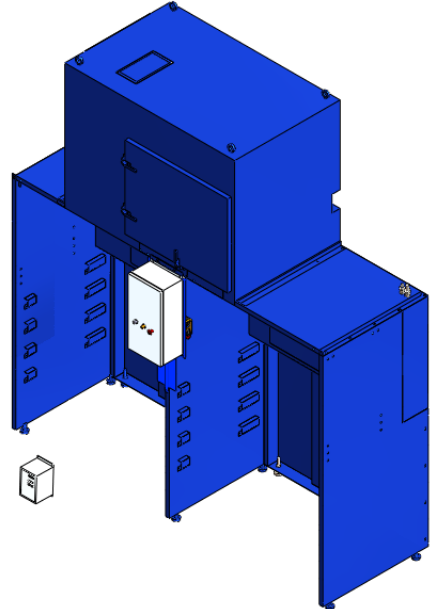

27. Fasten the VFD.

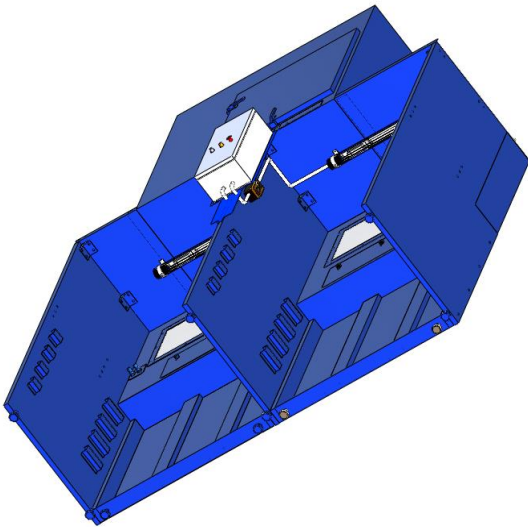

26.

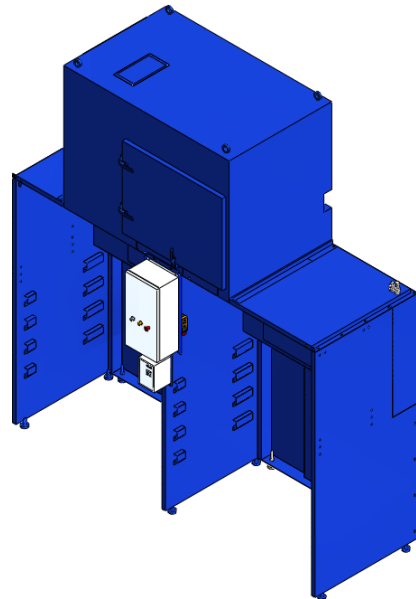

28.

AVANI Welding Station

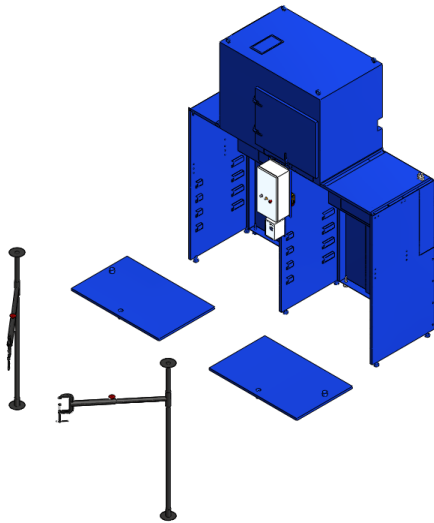

29. Secure the adjustable backshelf and C clamp in position, 1 pc of each mentioned per booth, total 2 pcs respectively for the two booths sitting together.

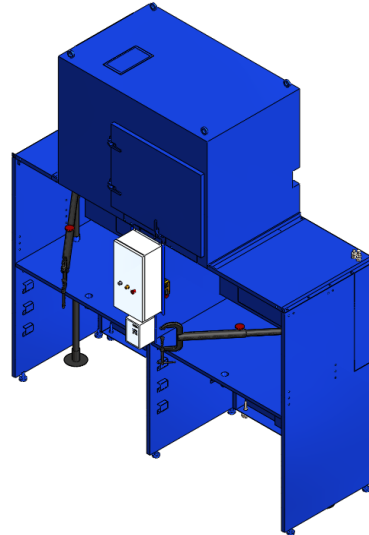

- 31.

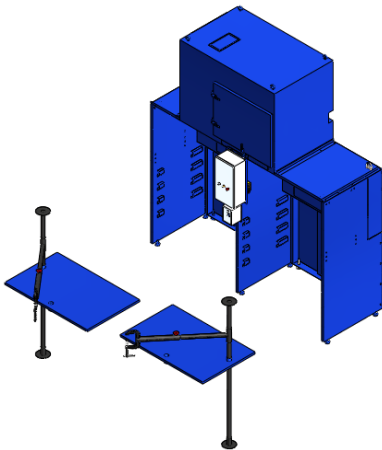

- 30.

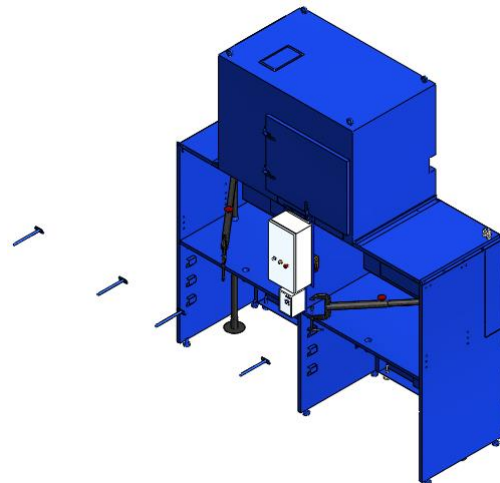

32. Attach curtain bar holders to the side panels, 2 pcs in each booth, total 4 pcs for the two booths sitting together.

AVANI Welding Station

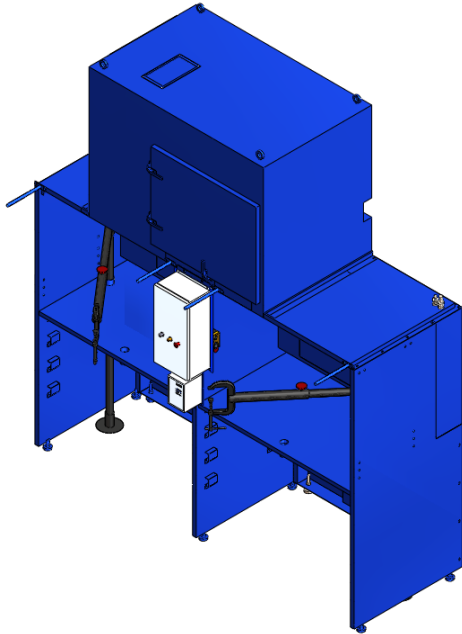

33.

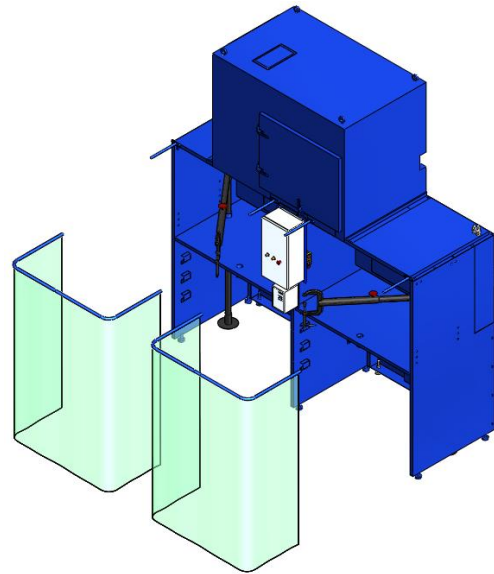

35. Connect the curtain bars to the holders.

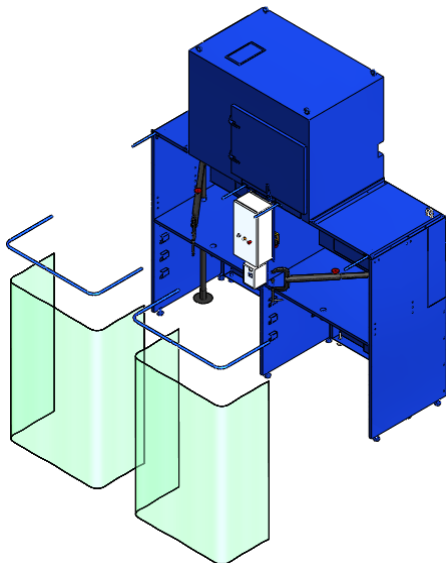

34. Curtains to the curtain bars

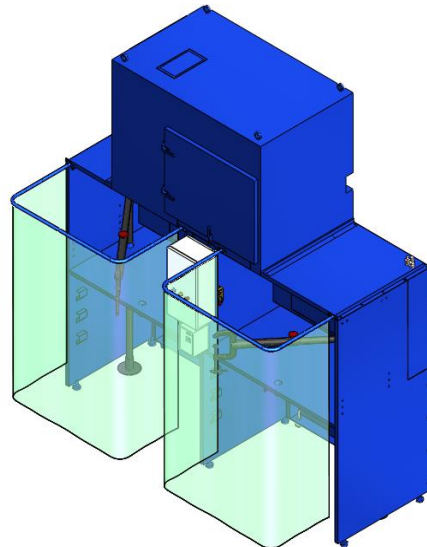

36. Assembly Completed.

AVANI Welding Station

Harlingen - WB-3000

Harlingen - WB-3000					
A	Left/Right Side Panel to Main Set			# of pack required	1
	Part Name	Specification	Q'ty	Total	
1	Left/Right Side Panel (WB-3000-29-1)		2	2	
2	Half-threaded Screw	3/8"*4"	14	14	
3	Lock Nut	3/8"	14	14	
4	Flat Washer	3/8"*OD23*2t	28	28	
B	Middle Panel to Main Set			# of pack required	1
	Part Name	Specification	Q'ty	Total	
1	Middle Panel (WB-3000-29-12)		1	1	
2	Half-threaded Screw	3/8"*5-1/2"	7	7	
3	Lock Nut	3/8"	7	7	
4	Flat Washer	3/8"*OD23*2t	14	14	
D	Left Side Panel Top Joints			# of pack required	1
	Part Name	Specification	Q'ty	Total	
1	Left Side Panel Top Joint (WB-3000-04-1)		2	2	
2	Hex Screw	5/16"*3/4"	8	8	
3	Flat Washer	5/16"*OD23*2t	8	8	
E	Right Side Panel Top Joints			# of pack required	1
	Part Name	Specification	Q'ty	Total	
1	Right Side Panel Top Joint (WB-3000-05-1)		2	2	
2	Hex Screw	5/16"*3/4"	8	8	
3	Flat Washer	5/16"*OD23*2t	8	8	
F	Adjacence of the Top Hood and Upper Part of the Left Backdraft Module			# of pack required	1
	Part Name	Specification	Q'ty	Total	
1	Hex Screw	5/16"*3/4"	16	16	
2	Lock Nut	5/16"	16	16	
3	Flat Washer	5/16"*OD18*2t	32	32	
H	Seal Board for Right Backdraft Module			# of pack required	1
	Part Name	Specification	Q'ty	Total	
1	Seal Board (WB-3000-16-1)		2	2	
2	Phillips Head Screw	1/4"*3/4"	20	20	
3	Foam Tape	3*6*1.3M	2	2	
J	Adjustable Backshelf Fixing Base (front)			# of pack required	1
	Part Name	Specification	Q'ty	Total	
1	Adjustable Backshelf Fixing Base (front) (WB-3000-08-1)		16	16	
2	Hex Screw	5/16"*3/4"	16	16	
3	Flat Washer	5/16"*OD18*2t	16	16	
K	Adjustable Backshelf Fixing Base (rear left)			# of pack required	1
	Part Name	Specification	Q'ty	Total	
1	Adjustable Backshelf Fixing Base (rear left) (WB-3000-08-3)		8	8	
2	Hex Screw	5/16"*3/4"	8	8	
3	Flat Washer	5/16"*OD18*2t	8	8	
L	Adjustable Backshelf Fixing Base (rear right)			# of pack required	1
	Part Name	Specification	Q'ty	Total	
1	Adjustable Backshelf Fixing Base (rear right) (WB-3000-08-2)		8	8	
2	Hex Screw	5/16"*3/4"	8	8	
3	Flat Washer	5/16"*OD18*2t	8	8	
C	Adjacence of the Left and Right Backdraft Modules			# of pack required	1
	Part Name	Specification	Q'ty	Total	
1	Hex Screw	5/16"*3/4"	12	12	
2	Flat Washer	5/16"*OD18*2t	12	12	
T	Top Hood for Right Booth			# of pack required	1
	Part Name	Specification	Q'ty	Total	
1	Hex Screw	5/16"*3/4"	9	9	
2	Flat Washer	5/16"*OD23*2t	9	9	
3	Hex Screw	3/8"*1"	8	8	
4	Flat Washer	3/8"*OD23*2t	8	8	
N	Overhead Lights			# of pack required	1
	Part Name	Specification	Q'ty	Total	
1	Working Light		2	2	
2	Hex Screw	1/4"*3/4"	8	8	
3	Flat Washer	1/4"*OD19*2t	8	8	
I	Curtain Rod			# of pack required	1
	Part Name	Specification	Q'ty	Total	
1	Curtain Rod(WB-3000-11-1)		4	4	
2	Hex Screw	5/16"*3/4"	8	8	
3	Flat Washer	5/16"*OD23*2t	16	16	
M	Control Box			# of pack required	1
	Part Name	Specification	Q'ty	Total	
1	Hex Screw	5/16"*3/4"	2	2	
2	Flat Washer	5/16"*OD18*2t	2	2	
3	Round Phillips Head Screw	#10*5/8"	1	1	
R	Curtain Bar			# of pack required	1
	Part Name	Specification	Q'ty	Total	
1	Curtain Bar (WB-3000-10-2)		2	2	
2	Curtain Bar (WB-3000-10-3)		2	2	
U	Adjacence of the Top Hood for Left Booth			# of pack required	1
	Part Name	Specification	Q'ty	Total	
1	Hex Screw	5/16"*3/4"	9	9	
2	Flat Washer	5/16"*OD23*2t	9	9	
3	Hex Screw	3/8"*1"	7	7	
4	Flat Washer	3/8"*OD23*2t	7	7	

AVANI Welding Station

Filters

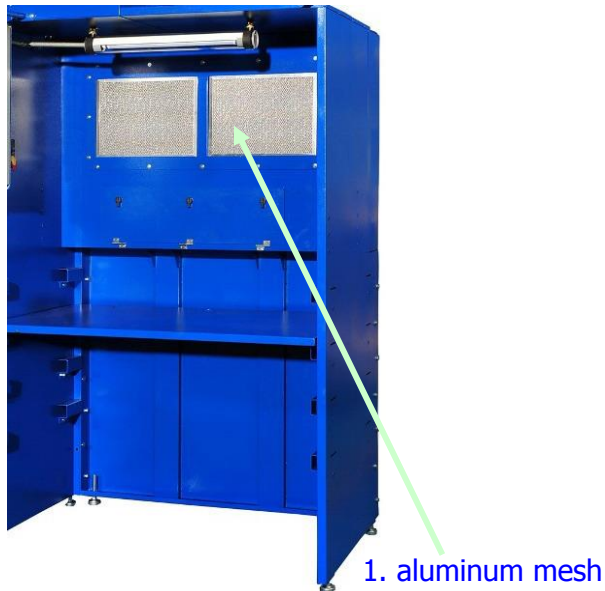

Figure 2 - Filters

1. **ALUMINUM MESH** captures sparks and steel chips.
 - (1) specification: 355 x 495 x 22 mm [14" x 19.5" x 0.87"]
 - (2) filter efficiency: 25 ~ 30%
 - (3) required quantity: 2 pcs per booth; total (4) pcs
2. **ALUMINUM MESH** captures sparks and steel chips.
 - (1) location: at the back of the cartridges before the air enters into the filter chamber.
 - (2) specification: 250 x 410 x 22 mm [9.9" x 16.2" x 0.87"]
 - (3) filter efficiency: 25 ~ 30%
 - (4) required quantity: 2 pcs per dust collector
3. **PLEATED CARTRIDGE FILTER** that can be cleaned by push-button pulse-jet cleaning of the cartridge filter from an onboard air tank.
 - (1) specification: Ø325 x 660 mm [Ø12.8" x 26"]
 - (2) required quantity: 4 pcs per dust collector
 - (3) material: 80/20 FR.
 - (4) filtering area: 22m² x 4 = 88m²

AVANI Welding Station

(946.88 ft²)

Filter Assembly

- **Aluminum mesh:**



1. Pull out the aluminum mesh and dispose it away. Install with a new one.

- **Aluminum mesh and cartridge filter installation procedure:**



1. Open the front maintenance door of the top mounted dust collector.



2. Loosen the knobs (circled in green). Release the filter handle fixing plates. Slide the filter handle fixing plates.

AVANI Welding Station



3. Pull down the left and right filter handles.
4. Take out the cartridge filter set.
5. Pull out the **aluminum mesh** at the back of the cartridges and install with a new one if this stage of filtration requires replacement.
6. Slide the new cartridge back into the track and push it to the end.
7. Push pack the left and right filter handles to secure the cartridges in position.



8. Pull up the left and right filter handles.



9. Attach the filter handle fixing plate upon the left and right filter handles. Slide and secure them in position. Fasten the plates and handles with knobs (circled in green).

AVANI Welding Station



10. Close the front maintenance door of the top mounted dust collector. Assembly completed.

AVANI Welding Station

Repair Parts List

Repair Parts List for Welding Station

Reference Number	Description	Part Number	Quantity
1	Seal Cover (upper)	OH07-01-WB-3000-1	1
2	Hex Screw (1/4"*3/4")	OH07-01-WB-3000-2	37
3	Flat Washer (1/4"*OD19*2t)	OH07-01-WB-3000-3	37
7	Main Chamber	OH07-01-WB-3000-7	1
8	Eye Bolt	OH07-01-WB-3000-8	4
9	Impeller	OH07-01-WB-3000-9	1
10	Motor Base	OH07-01-WB-3000-10	1
11	Flat Washer (5/16"*OD23*2t)	OH07-01-WB-3000-11	12
12	Hex Screw (5/16"*3/4")	OH07-01-WB-3000-12	12
13	Motor	OH07-01-WB-3000-13	1
14	Hex Screw (5/16"*3/4")	OH07-01-WB-3000-14	4
15	Flat Washer (5/16"*OD23*2t)	OH07-01-WB-3000-15	8
16	Hex Nut (5/16")	OH07-01-WB-3000-16	4
17	Hex Screw (5/16"*3/4")	OH07-01-WB-3000-17	4
18	Motor Support Base	OH07-01-WB-3000-18	1
19	Flat Washer (5/16"*OD23*2t)	OH07-01-WB-3000-19	8
20	Seal Cover (side)	OH07-01-WB-3000-20	1
21	Flat Washer (1/4"*OD19*2t)	OH07-01-WB-3000-21	18
22	Hex Screw (1/4"*3/4")	OH07-01-WB-3000-22	18
23	Pressure Gauge	OH07-01-WB-3000-23	1
24	Compression Latch Base	OH07-01-WB-3000-24	3
25	Flat Washer (1/4"*OD12*2t)	OH07-01-WB-3000-25	9
26	Hex Screw (1/4"*3/4")	OH07-01-WB-3000-26	9
27	Countersunk Inner Hex Screw	OH07-01-WB-3000-27	6

AVANI Welding Station

Reference Number	Description	Part Number	Quantity
28	Flat Washer (1/4"*OD19*2t)	OH07-01-WB-3000-28	9
29	Hex Screw (1/4"*3/4")	OH07-01-WB-3000-29	9
30	Control Box	OH07-01-WB-3000-30	1
31	Drawer	OH07-01-WB-3000-31	2
32	Countersunk Inner Hex Screw	OH07-01-WB-3000-32	12
33	Compression Latch	OH07-01-WB-3000-33	3
34	Door	OH07-01-WB-3000-34	1
35	Filter Handle (left)	OH07-01-WB-3000-35	2
36	Filter Handle Fixing Plate	OH07-01-WB-3000-36	2
37	Filter Handle (right)	OH07-01-WB-3000-37	2
38	Aluminum Mesh	SV-FT-A-07-E0037	2
39	Pleated Cartridge Filter	SV-FT-C-08-325*660LB	4
40	Flange Nut	OH07-01-WB-3000-40	8
41	Hinge	OH07-01-WB-3000-41	2
42	Cap Screw	OH07-01-WB-3000-42	8
43	Top Hood for Left Booth	OH07-01-WB-3000-43	1
44	Hex Screw (5/16"*3/4")	OH07-01-WB-3000-44	10
45	Flat Washer (5/16"*OD23*2t)	OH07-01-WB-3000-45	10
46	Hex Screw (3/8"*1")	OH07-01-WB-3000-46	10
47	Flat Washer (3/8"*OD23*2t)	OH07-01-WB-3000-47	10
48	Top Hood for Right Booth	OH07-01-WB-3000-48	1
49	Curtain Rod Support	OH07-01-WB-3000-49	4
50	Curtain Rod - 1	OH07-01-WB-3000-50	2
51	Curtain Rod - 2	OH07-01-WB-3000-51	2
52	Working Light	OH07-01-WB-3000-52	2

AVANI Welding Station

Reference Number	Description	Part Number	Quantity
53	Flat Washer (1/4"*OD19*2t)	OH07-01-WB-3000-53	8
54	Hex Screw (1/4"*3/4")	OH07-01-WB-3000-54	8
55	Pipe Connector Panel (left booth top)	OH07-01-WB-3000-55	1
56	Phillips Head Screw (1/4"*3/4")	OH07-01-WB-3000-56	20
57	Seal Board for Left/Right Backdraft Module	OH07-01-WB-3000-57	2
58	Phillips Head Sheet Metal Screw (5/32"*1/2")	OH07-01-WB-3000-58	12
59	Back Seal Board for Pipes	OH07-01-WB-3000-59	2
60	Hex Screw (5/16"*3/4")	OH07-01-WB-3000-60	16
61	Flat Washer (5/16"*OD23*2t)	OH07-01-WB-3000-61	32
62	Lock Nut (5/16")	OH07-01-WB-3000-62	16
63	Hex Screw (5/16"*3/4")	OH07-01-WB-3000-63	12
64	Flat Washer (5/16"*OD23*2t)	OH07-01-WB-3000-64	12
65	Backdraft (Left)	OH07-01-WB-3000-65	1
66	Backdraft (Right)	OH07-01-WB-3000-66	1
67	Pipe Connector Panel (front) for left booth	OH07-01-WB-3000-67	1
68	Pipe Connector Panel (front) for right booth	OH07-01-WB-3000-68	1
69	Bushing (3/4"*1/4")	OH07-01-WB-3000-69	4
70	Bushing (3/4"*3/8")	OH07-01-WB-3000-70	4
71	Nozzle (1/4")	OH07-01-WB-3000-71	4
72	Nozzle (3/8")	OH07-01-WB-3000-72	4
73	Phillips Head Sheet Metal Screw	OH07-01-WB-3000-73	8

AVANI Welding Station

Reference Number	Description	Part Number	Quantity
	(5/32"*1/2")		
74	Nipple	OH07-01-WB-3000-74	4
75	Elbow (3/4")	OH07-01-WB-3000-75	4
76	Nipple	OH07-01-WB-3000-76	4
77	Pipe Connector Panel (right booth top)	OH07-01-WB-3000-77	1
78	Dust-tight Gasket	OH07-01-WB-3000-78	4
79	Connector (3/4")	OH07-01-WB-3000-79	4
80	Phillips Head Sheet Metal Screw (5/32"*1/2")	OH07-01-WB-3000-80	6
81	Right Side Panel	OH07-01-WB-3000-81	1
82	Half-threaded Screw (3/8"*4")	OH07-01-WB-3000-82	14
83	Flat Washer (3/8"*OD23*2t)	OH07-01-WB-3000-83	28
84	Lock Nut (3/8")	OH07-01-WB-3000-84	14
88	Adjustable Backshelf Fixing Base (Right)	OH07-01-WB-3000-88	8
89	Flat Washer (5/16"*OD23*2t)	OH07-01-WB-3000-89	8
90	Hex Screw (5/16"*3/4")	OH07-01-WB-3000-90	8
91	Adjustable Backshelf Fixing Base (front)	OH07-01-WB-3000-91	16
92	Flat Washer (5/16"*OD23*2t)	OH07-01-WB-3000-92	16
93	Hex Screw (5/16"*3/4")	OH07-01-WB-3000-93	16
94	Adjustable Feet	OH07-01-WB-3000-94	10
95	Corner Gusset	OH07-01-WB-3000-95	2
96	Corner Gusset	OH07-01-WB-3000-96	2
97	Hex Screw (5/16"*3/4")	OH07-01-WB-3000-97	16

AVANI Welding Station

Reference Number	Description	Part Number	Quantity
98	Flat Washer (5/16"*OD23*2t)	OH07-01-WB-3000-98	16
99	Flat Washer (5/16"*OD23*2t)	OH07-01-WB-3000-99	16
100	Hex Screw (5/16"*3/4")	OH07-01-WB-3000-100	16
101	Control Box Base	OH07-01-WB-3000-101	1
102	Phillips Head Sheet Metal Screw (5/32"*1/2")	OH07-01-WB-3000-102	1
103	Middle Panel	OH07-01-WB-3000-103	1
104	Drawer Lock	OH07-01-WB-3000-104	6
105	Round Phillips Head Screw (3/16"*12")	OH07-01-WB-3000-105	24
106	Hinge	OH07-01-WB-3000-106	6
107	Backdraft Drawer	OH07-01-WB-3000-107	2
108	Aluminum Mesh	SV-FT-A-07-E0036	4
109	Phillips Head Screw (1/4"*3/4")	OH07-01-WB-3000-109	32
110	Filter Frame	OH07-01-WB-3000-110	2
111	Lock Nut (3/8")	OH07-01-WB-3000-111	7
112	Flat Washer (3/8"*OD23*2t)	OH07-01-WB-3000-112	14
113	Half-threaded Screw (3/8"*5-1/2")	OH07-01-WB-3000-113	7
115	Left Side Panel	OH07-01-WB-3000-115	1
116	Adjustable Backshelf Fixing Base (Left)	OH07-01-WB-3000-116	8
117	Flat Washer (5/16"*OD23*2t)	OH07-01-WB-3000-117	8
118	Hex Screw (5/16"*3/4")	OH07-01-WB-3000-118	8
119	Adjustable Backshelf (Left)	OH07-01-WB-3000-119	1
120	Knob (5/16"*3/4")	OH07-01-WB-3000-120	2
121	Light Switch	OH07-01-WB-3000-121	2

AVANI Welding Station

Reference Number	Description	Part Number	Quantity
122	Phillips Head Sheet Metal Screw (5/32"*1/2")	OH07-01-WB-3000-122	4
123	VFD	OH07-01-WB-3000-123	1
124	Cap Screw	OH07-01-WB-3000-124	4
125	Hex Nut	OH07-01-WB-3000-125	4
126	Adjustable Backshelf (Right)	OH07-01-WB-3000-126	1
127	C clamp – 1	OH07-01-WB-3000-127	2
128	C clamp – 2	OH07-01-WB-3000-128	2
129	Knob (5/16"*1-1/2")	OH07-01-WB-3000-129	4
130	C clamp – 3	OH07-01-WB-3000-130	2
131	Hex Screw (3/8"*2-2/1")	OH07-01-WB-3000-131	2
132	C clamp Base	OH07-01-WB-3000-132	2
133	Flat Washer (5/16"*OD23*2t)	OH07-01-WB-3000-133	8
134	Hex Screw (5/16"*3/4")	OH07-01-WB-3000-134	8

AVANI Welding Station

Control Panel Explanation

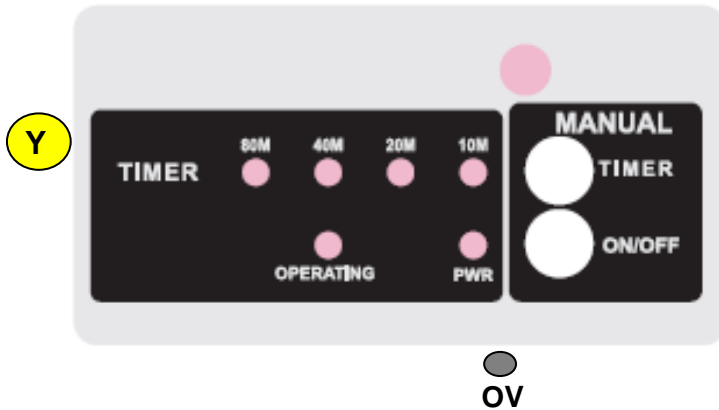

8M/4M/2M/1M: Time setting indicating light (accumulated function)

TIMER: Time adjusting button

ON/OFF: ON / OFF button

PWR: Power indicating light

OPERATING: Operation indicating light

Y : Manual air pulse jet cleaning button

OV : Overload 25A

OV

Accumulated Function:

1. When operating, timer will automatically set to release air in every 1 minute.
2. Press TIMER once, the time setting light will be switched to 2M. Press it one more time, both 1M and 2M lights will be on, so the time is accumulated to clean in every 3 minutes.
3. Press TIMER again, the time setting light will be switched to 4M.
4. Press it one more time, both 1M and 4M lights will be on and the time is

accumulated to clean in every 5 minutes. Press it again, both 2M and 4M lights will be on and the time is accumulated to clean in every 6 minutes. Press it again, the 1M, 2M and 4M lights will be on and the time is accumulated to clean in every 7 mins.

5. Following this cycle, the time setting may be adjusted manually to 1, 2, 3, 4, 5, 6, 7, 8, 9, 10, 12 and 15 mins. The maximum allowance time setting would be 15 mins.

AVANI Type I Dust Collector

Pulse Cleaning Setting:

Timer Operation (Accumulated Function)				
Pulse Frequency	8M	4M	2M	1M
ON				●
1			●	
2			●	●
3		●		
4		●		●
5		●	●	
6		●	●	●
7	●			
8	●			●
9	●		●	
10	●	●		
11	●	●	●	●

AVANI Type I Dust Collector

Appendix 1 - Electrical Circuit Diagram

WB-3000



AVANI Welding Station

Control box for WB-3000

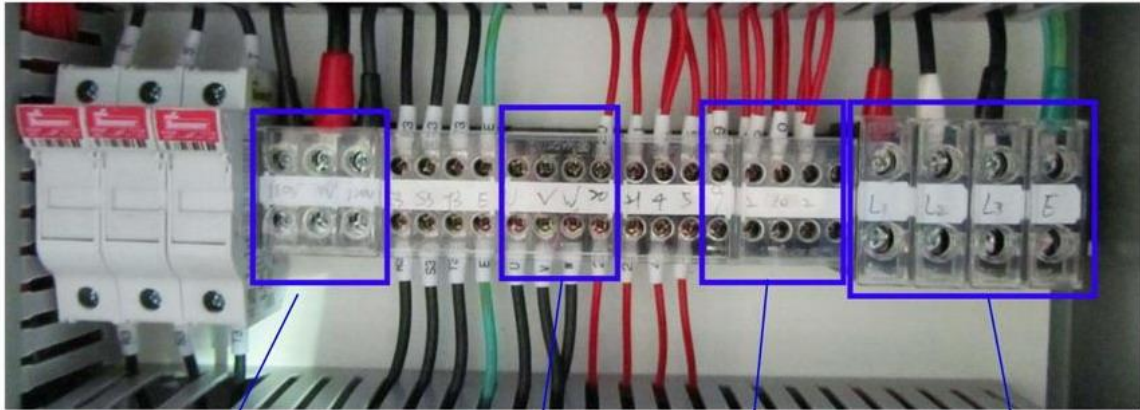

➤ Connect to light power supply for WB-3000.

➤ Magnetic valve wirings for WB-3000.

➤ Connect to motor power supply for WB-3000.

➤ Connect to main power supply for WB-3000.

AVANI Welding Station

The wiring of right light switch

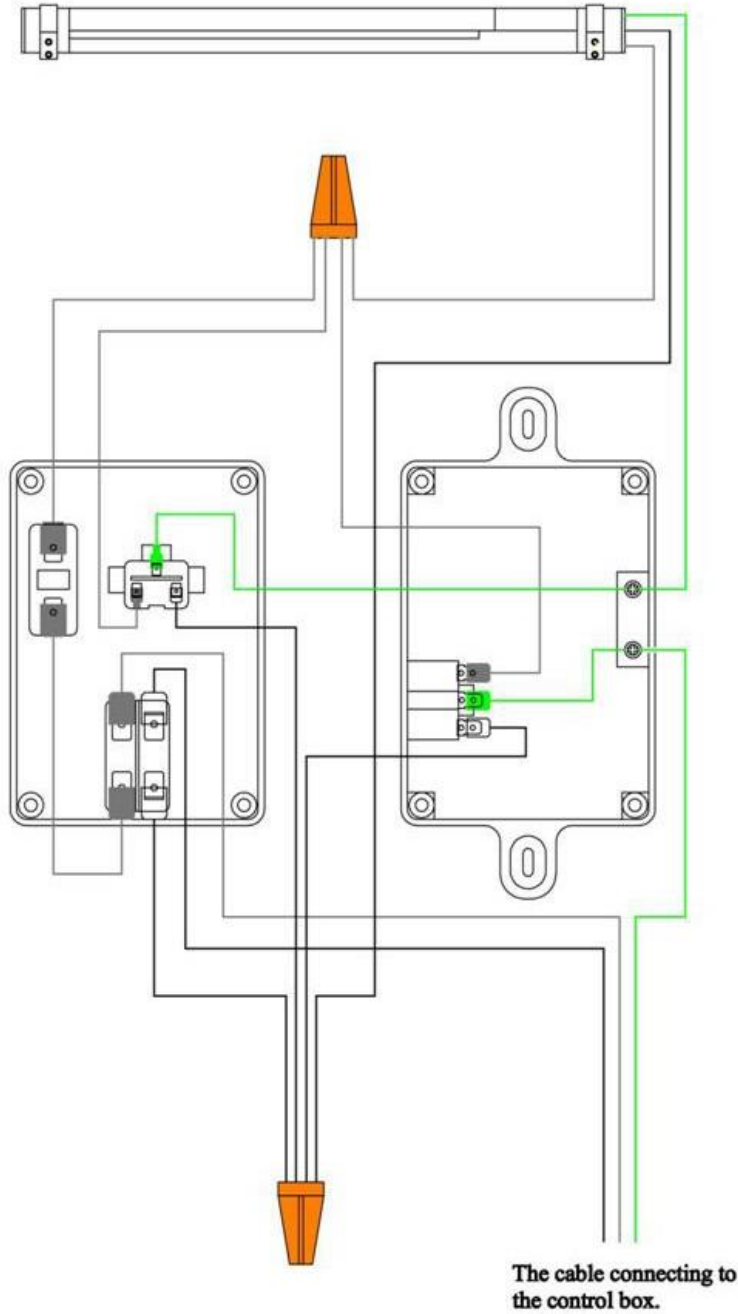

AVANI Welding Station

The wiring of left light switch

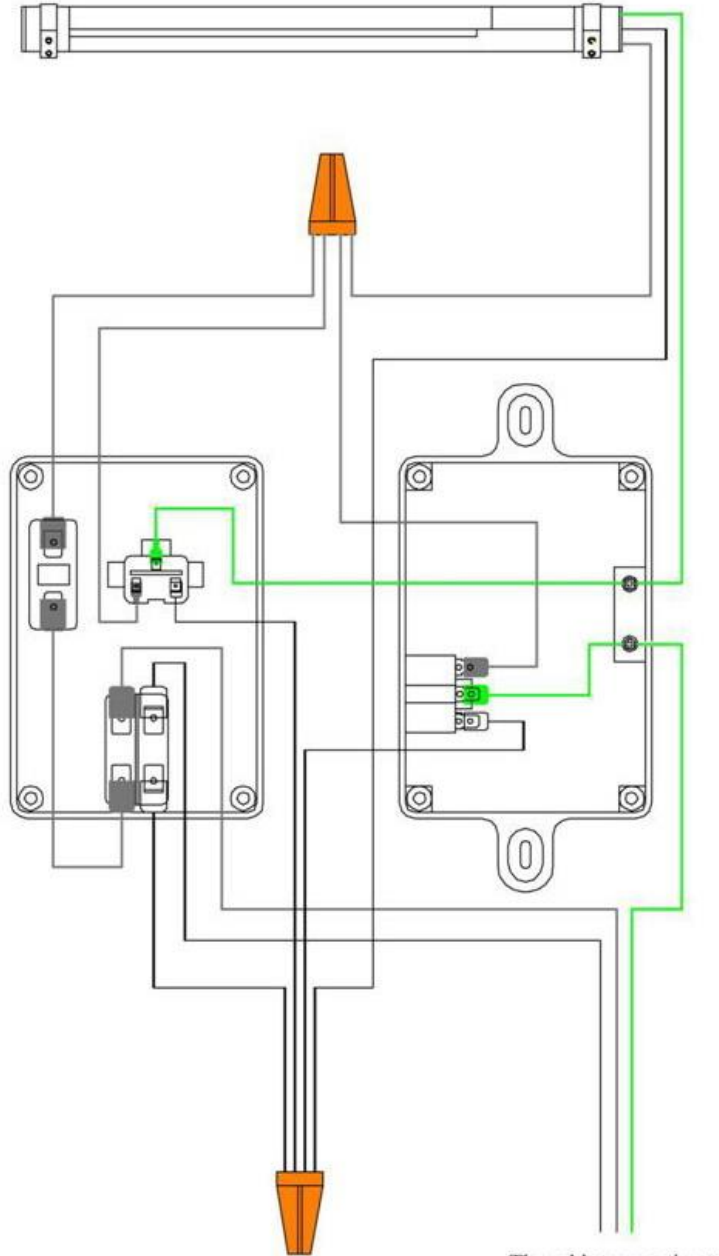

The cable connecting to the control box.

AVANI Welding Station

Main Electrical Box Wiring For WB-3000 (460V)

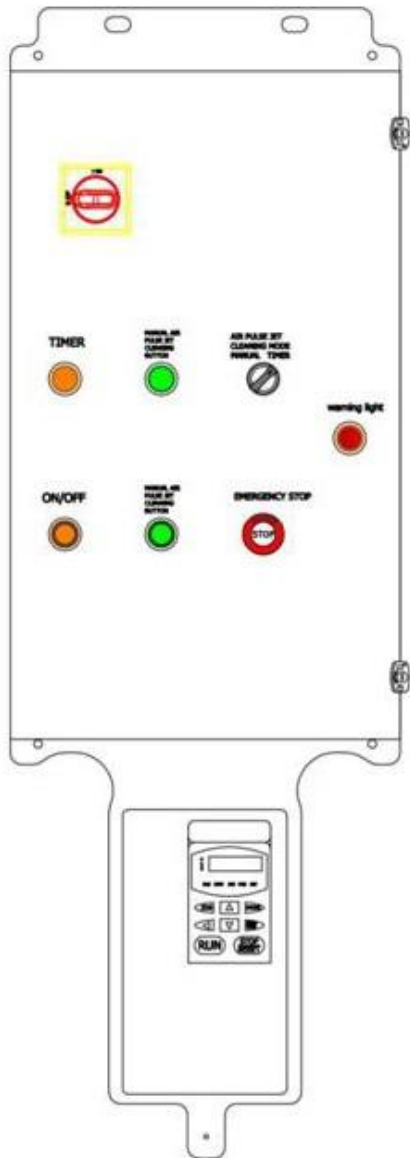

AVANI Welding Station

Main Electrical Box Wiring For WB-3000 (460V)

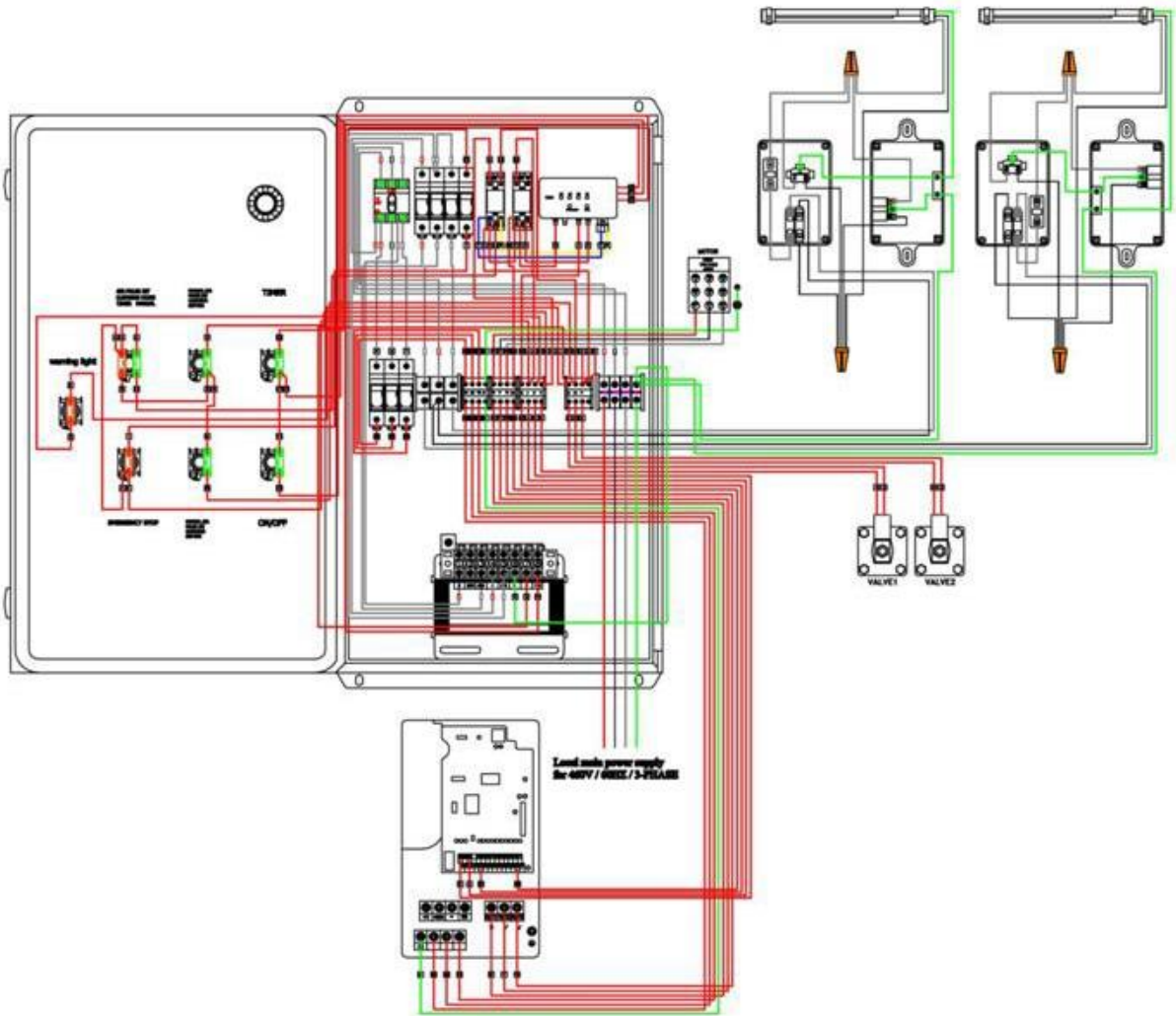

AVANI Welding Station

Main Electrical Box Wiring For WB-3000 (460V)

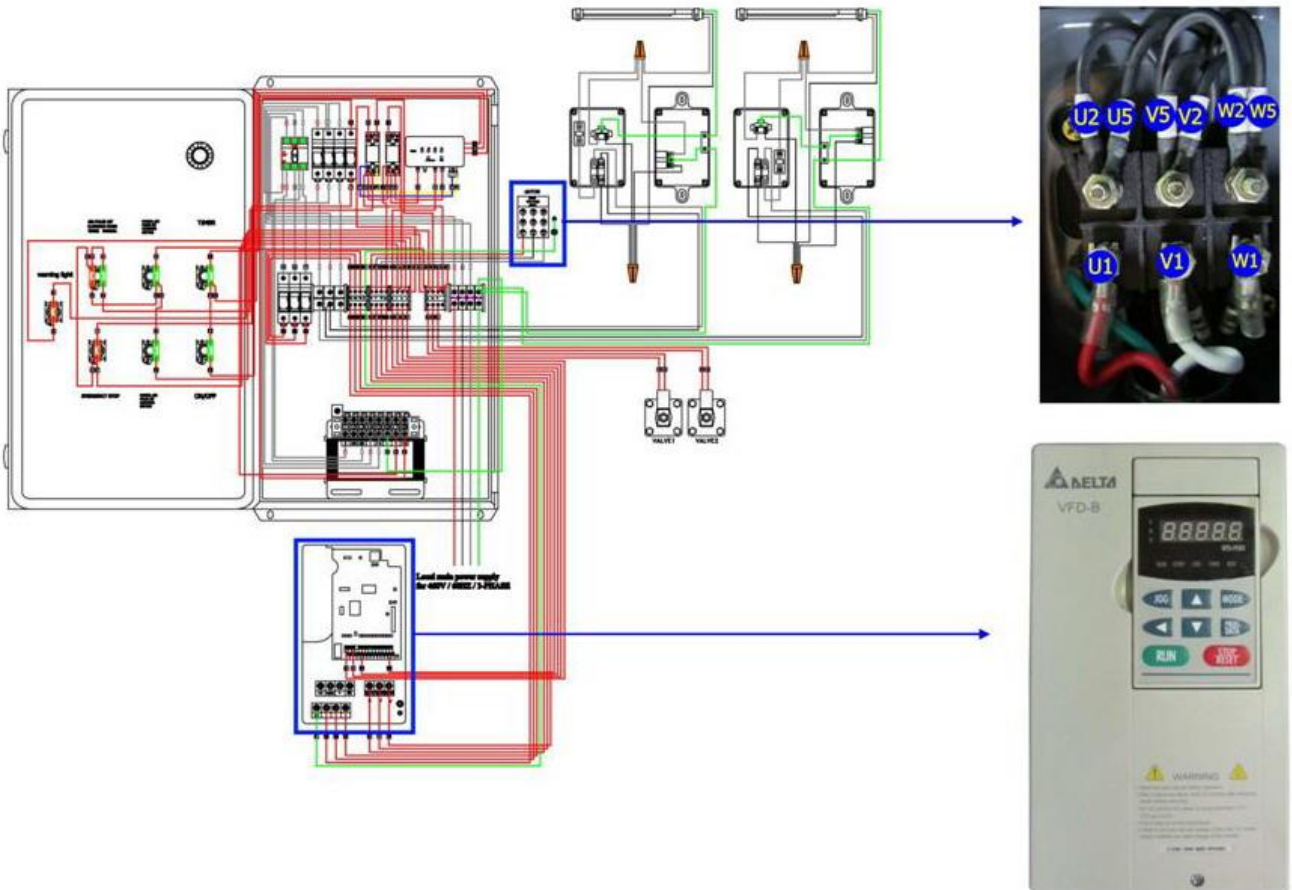

AVANI Welding Station

Main Electrical Box Components for WB-3000 (460V)



◆ IC Board (Front)



◆ IC Board (Back)

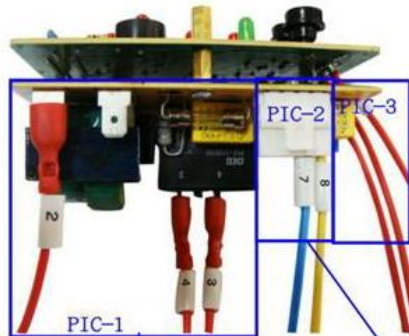

PIC-3

◆ 12 : TIMER.

◆ 13: ON/OFF.

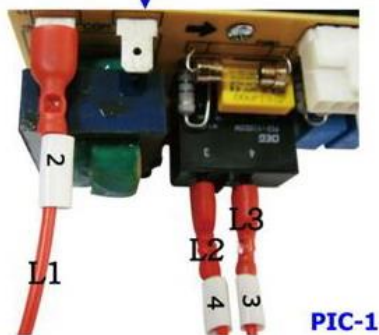

PIC-1

◆ L1/L2 : The main power.

◆ L3 : The blower.

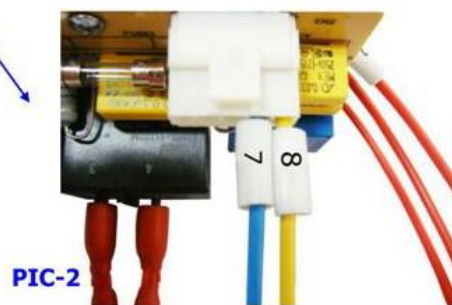

PIC-2

◆ Air pulse jet system.

AVANI Welding Station

Main Electrical Box Components for WB-3000 (460V)

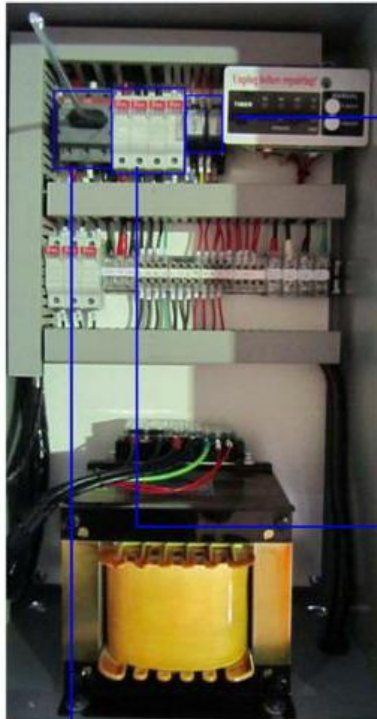

◆ Relay.



◆ Fuse bus.

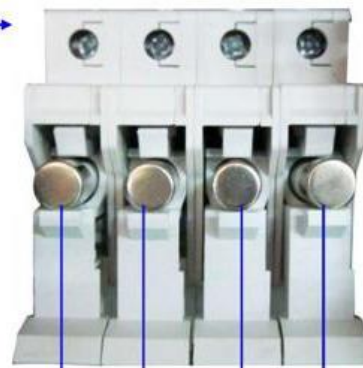

◆ Panel disconnect switch.



KTK-15 KTK-15 KTK-15 KTK-4

AVANI Welding Station

Main Electrical Box Components for WB-3000 (460V)

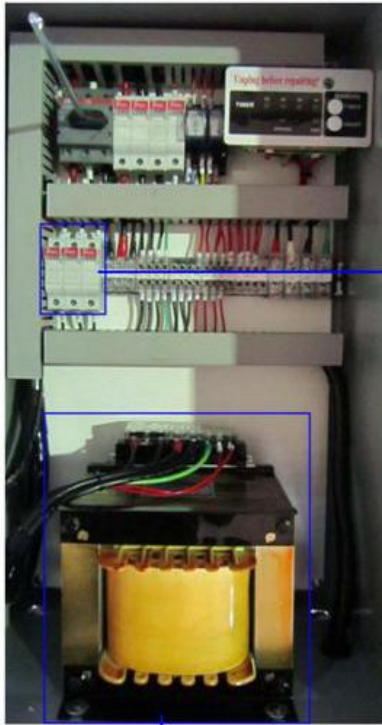

◆ Fuse bus for VDF.



◆ Transformer for 460V



FNQ-R-15 FNQ-R-15 FNQ-R-15

AVANI Welding Station

Main Electrical Box Components for WB-3000 (460V)

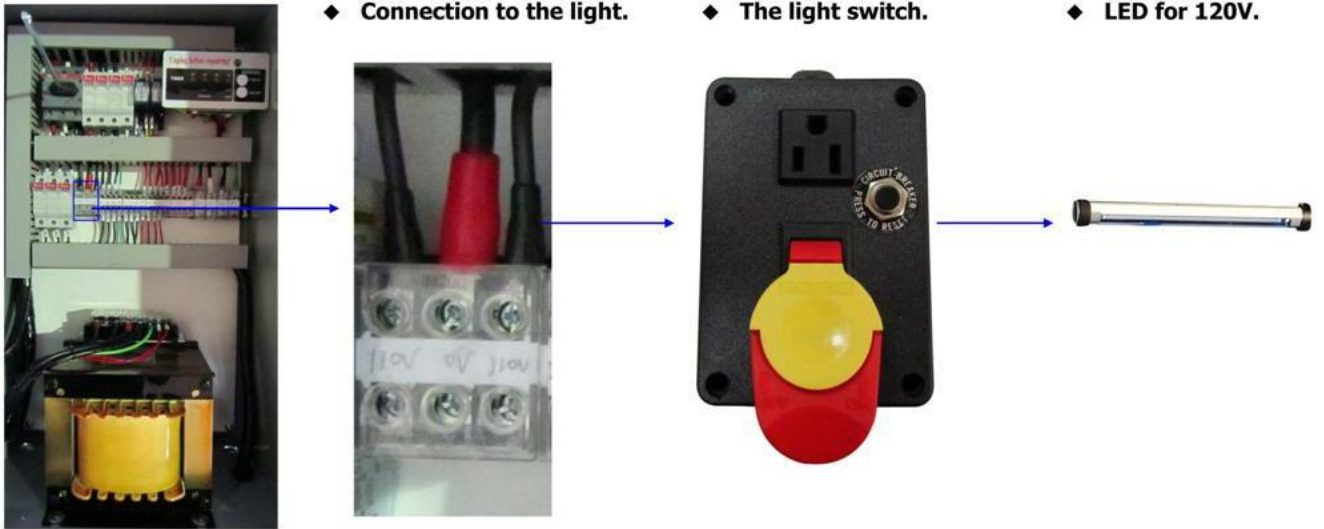

AVANI Welding Station

The Wiring of right light switch for WB-3000 (460V)

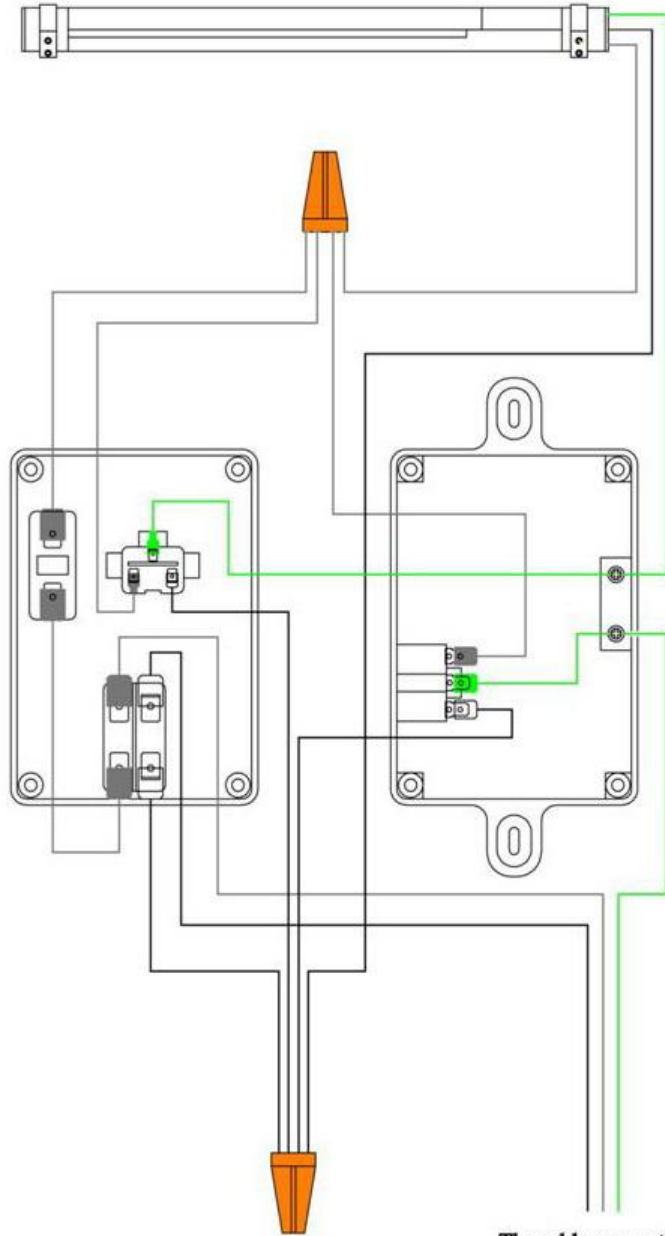

The cable connecting to the control box.

AVANI Welding Station

The Wiring of left light switch for WB-3000 (460V)

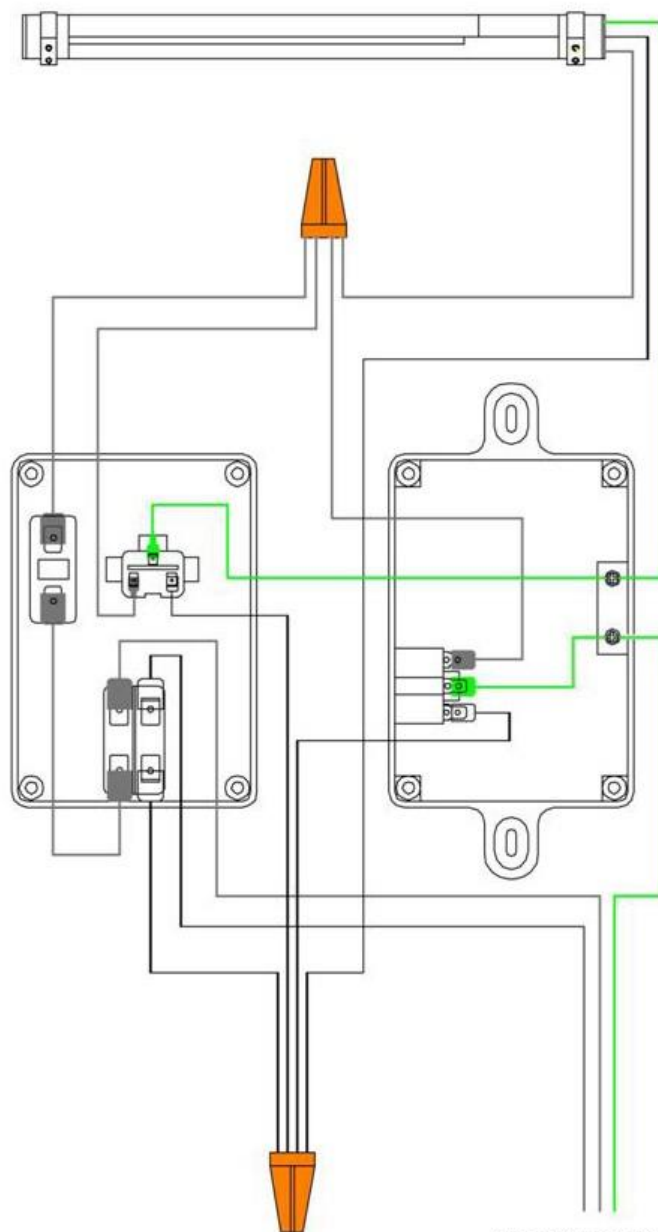

The cable connecting to
the control box.

AVANI Type I Dust Collector

Main Electrical Box Components for WB-3000 (460V)

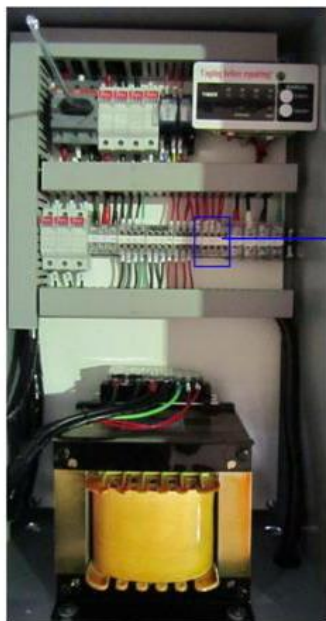

◆ Air pulse jet system.



◆ Valve.



AVANI Type I Dust Collector

Contact Information

Avani Environmental Intl. Inc.

95 Cypress Drive,

Youngsville, NC 27596

Email: info@avanienvironmental.com

www.avanienvironmental.com

Customer Service: info@avanienvironmental.com

Tel: 919-570-2862 ext. 5167

Engineering Service: engineering@avanienvironmental.com

Tel: 919-570-2862 ext. 5162