

AVANI Top Mounted Dust Collector



Customer:	
Customer PO#:	
AVANI SO#:	Tested By:
Serial #:	142401
Ship Date / Install Date:	

Please read and save these instructions. Read carefully before attempting to assemble, install, operate or maintain the product described. Protect yourself and others by observing all safety information. Failure to comply with instructions could result in personal injury and/or property damage! Retain instructions for future reference.



AVANI Top Mounted Dust Collector

General Safety Information

MACHINE WARNING SIGNS

DANGER

Indicates an imminently hazardous situation which, if not avoided, will result in death or serious injury.

WARNING

Indicates a potentially hazardous situation which, if not avoided, could result in death or serious injury.

CAUTION

Indicates a potentially hazardous situation which, if not avoided, may result in minor or moderate injury.

Used without the safety alert symbol () indicates potentially hazardous situation which, if not avoided, may result in property damage.



Warning of electric shock



Do not expose the equipment to rain or use in damp locations.



Figure 1



Do not use the equipment around flammable products, if not avoided, sparks can ignite vapors from flammable products.

Read and understand all warnings and operating instructions before using this equipment. Failure to follow all instructions may result in electric shock, fire, and/or serious personal injury or property damage.



Please read and save these instructions. Read carefully before attempting to assemble, install, operate or maintain the product described. Protect yourself and others by observing all safety information. Failure to comply with instructions could result in personal injury and/or property damage! Retain instructions for future reference.

avani
environmental®



AVANI Top Mounted Dust Collector

TABLE OF CONTENT

MACHINE WARNING SIGNS	2
Specifications.....	3
ADDITIONAL WELDING FUME EXTRACTOR SAFETY RULES	5
Assembly.....	6
Installation	6
ELECTRICAL INSTALLATION.....	6
Operation	7
Filters.....	11
Filter Assembly	11
Repair Parts Illustration and Repair Parts List.....	16
Repair Parts List.....	17
Appendix 1 - Electrical Circuit Diagram	23
Contact Information	26

Specifications

Motor	1.5 HP
.....	120V / 60Hz / 1Ph
Air Volume (C.F.M.)	850 Ft ³ /Min (24 M ³ /Min)
Filtration Stages	1st – aluminum mesh x 1 pc
.....	Spec: 485 x 485 x 22 mm [19.1" x 19.1" x 0.87"]
.....	2nd – STAINLESS NET x 1 pc
.....	Spec: 600 x 600 x 50 mm [23.6" x 23.6" x 2.04"]
.....	3rd – 95% ASHRAE FILTER x 1 pc
.....	Spec: 595 x 595 x 300 mm [24.3" x 24.3" x 11.91"]
Dimension	245 x 167 x 95 cm (96.5" x 65.8" x 37.4")
.....	163 x 104 x 124 cm(64.2" x 41" x 48.9")

Please read and save these instructions. Read carefully before attempting to assemble, install, operate or maintain the product described. Protect yourself and others by observing all safety information. Failure to comply with instructions could result in personal injury and/or property damage! Retain instructions for future reference.



AVANI Top Mounted Dust Collector

General Safety Information

(Continued)

▲ WARNING

*Use this product
carefully to*

*effectively avoid any possible danger.
Observe the following safety
regulations to avoid bodily injury due
to electrocution during use.*

Read this Manual carefully before operating the product and preserve the Operation Manual properly.

1. Keep work area clean and organized.
 - A disorderly working environment will cause inconvenience and danger during operation.
2. Check if the working environment is suitable for using the product.
 - Do not use the product in a humid environment.
 - Use the product in a good working environment to reduce risks.
 - Do not use the product in a flammable gas or liquid environment to avoid danger.
3. Keep other persons away from the product, except for the operator, to avoid danger.
 - Do not let children get close to the product. All wires used by the product shall be in a safe location to prevent children from touching them.
4. All tools shall be safely stored.
 - When the tools are not used, please store them in a dry place safely beyond the reach and access of children.
5. If the machine breaks down, contact a service technician. Do not attempt to repair and possibly damage the machine.
6. When using the product, be sure to put on a welding suit and mask.
7. Use the electrical wires correctly.
 - During use, do not drag the electrical wires forcefully. Do not use these wires if fraying or current leakage occurs to avoid injury to the operator.
8. Before replacing parts, shut off power to the machine.
 - Check that the switch is in "on" or "off" position. Do not attempt the replacement when the machine is running. To replace parts or filter material, make certain that the switch

Please read and save these instructions. Read carefully before attempting to assemble, install, operate or maintain the product described. Protect yourself and others by observing all safety information. Failure to comply with instructions could result in personal injury and/or property damage! Retain instructions for future reference.

avani
environmental®



AVANI Top Mounted Dust Collector

is "off".

9. Use the power cord correctly. The total length of power cord shall not exceed 10 feet to avoid low power due to a drop in voltage and to prevent a possible hazard.

▲ WARNING

When connecting the product, always follow the instructions in the Operation Manual to avoid injuries.

10. Care and Maintenance:

- Confirm that the parts/accessories have been fully assembled and will not adversely affect the machine operation.
 - Check if the machine is operated properly.
 - Replace damaged parts or accessories according to the instructions of the Manual. If the said instructions are not specified in the Manual, have a professional technician carry out the maintenance or replacement.
 - Check that the electrical specifications of this machine meet safety requirements, and that the maintenance is carried out by a professional technician. Use original manufacturer's parts and accessories to avoid injury.
- If a problem occurs, contact your dealer immediately.

ADDITIONAL WELDING FUME EXTRACTOR SAFETY RULES

The Welding Fume Extractor can be dangerous if it is operated incorrectly. Therefore, the product must be used cautiously to avoid causing a hazard or damage. Unnecessary injuries may occur by failing to follow the instructions of the Safety Rules Manual. Be sure to put on protection equipment or suit that can protect your body, such as helmet and eye mask to avoid injuries from occurring. If any doubts or any unfitness occurs during use, be sure to stop the operation immediately. Keep in mind that the user shall be liable for using according to the specified safety rules and for operating the machine correctly.

1. Read this Manual carefully before operating the product.
2. Be sure to follow local electrical and safety regulations and observe the electrical safety standards practiced in the relevant area. All electrical wire connections and installation shall be carried out by a professional technician.
3. Do not operate the product near flammable materials, as sparks may

AVANI Top Mounted Dust Collector

ignite these materials and cause an explosion. Please confirm there aren't any flammables near the working site to avoid hazard.

4. This product is suitable for collecting smoke and welding oil gas. Do not use it in collecting iron chips and dust at the same time to avoid producing sparks.
5. Before replacement of parts or filter materials, be certain that the switch is disconnected.
6. Do not kink the power cord and keep it away from oil, chemicals or flammables.
7. Check that the voltage, phase count and grounding wire match the machine requirements.
8. When the fan blades are operated at high speed, do not reach hand near these blades to prevent finger from breaking or clothes/necktie from getting caught. Do not put the hand or foreign matter into the air inlet to avoid getting caught in the high-speed rotation of fan blades.
9. When not in use, all air inlets of Welding Smoke Treatment Machine shall be covered.

Assembly

▲WARNING

Do not connect the Welding Smoke

Treatment Machine before the assembly is finished and you have read and understood all of the precautions stated in the Manual.

NOTE: For correct assembly, refer to the Illustrations and Parts List on pages 15-21.

Installation

MOVING AND TRANSPORTATION

The net weight of this machine is about 1256.6 lbs. It CANNOT be handled and transported without the help of lifting tools. For your safety, read all instructions

carefully.

▲WARNING

Do not move

without the help of others to avoid causing danger.

ELECTRICAL INSTALLATION

POWER CONNECTION

1. Confirm that the power is properly connected under normal power supply condition. It is recommended to provide manual shutdown device before connecting power.
2. It is recommended to protect the control equipment with suitable grade of fuse, and the length of fuse and power cord

AVANI Top Mounted Dust Collector

shall not be over 10 feet.

SHUTDOWN

1. Disconnect power by manual method.
2. When stopping operation, check if the switch is under off status.

EARTHING WIRE

Connect yellow/green wires to the earthing wire power jack. Confirm that the earthing wire has been properly connected before connecting main power cord to the machine at all times.



WARNING

***Do not disconnect
the wiring jack***

before cutting off power!

POWER INSTALLATION AND STORAGE

The electrical power is configured as following. If conditions are beyond the scope stated below, then it is required to ensure that the power is well arranged and safe.

- Ambient temperature: Between 41°F and 131°F. If the time is over 24 hours, then the ambient average temperature shall not be over 122°F.
- Humidity: Between 30% and 95%
- Altitude: 3,280 feet
- Moving and Storing: -13°F to 131°F. For short-time storage (less than 24 hours), the storage temperature can be up to 158°F.

Operation

PRIOR TO START UP

Purpose: The Welding Fume Extractor is specially suitable for treating the smoke generated during ordinary welding processing work, which can effectively collect and screen the smoke resulting from the welding work in maintaining the air quality of the working environment.

- Before starting the machine, be sure to read this Manual carefully.
- Before starting the machine, check if relevant safety protection measures have been taken according to the Manual.
- Before starting the machine, watch the motor turning direction according to the instruction of arrow direction.

START UP

1. To ensure satisfactory performance for the Welding Smoke Treatment Machine, please confirm the air volume, power and the matching table of the Welding Smoke Treatment Machine.
2. Connect power according to electrical installation procedure after installing the Welding Smoke Treatment Machine and the table. Disconnect power according to

AVANI Top Mounted Dust Collector

electrical installation procedure when the machine is not used.

3. The Welding Smoke Treatment Machine shall be turned on and off by pushing I/O button. Under normal operation status, use such I/O button.

Unpacking

The machine should be unpacked carefully. Check if the machine and components are consistent with those indicated in the Parts List. If any doubt arises or when the components are incomplete, contact your dealer.

OPERATION – Filter Cleaning

1. Attached compressed air to the unit for cleaning purposes, at a source pressure of 90 PSI. The connection point is accessed by removing the panel on the side of the unit where the PSI label is in place and requires a 1/4" NPT fitting. A regulator must be incorporated in line to set pressure. Do not exceed 90 PSI pressure.



2. Refer to control panel for initiating power to the motor and subsequent vacuum from the unit.
3. The vacuum hood should be placed an approximate distance of 12" from the smoke source for efficient operation.
4. During operation, the pressure gauge should maintain a reading of 2" WIC pressure or less.
5. If pressure exceeds 2" WIC, or you experience a reduction in vacuum, proceed with the following action(s)
 - The unit should be powered off and the button pushed one to two times.
 - Cleaning as noted above should be daily or as any decrease in vacuum

AVANI Top Mounted Dust Collector

is observed.

6. If pressure continues to exceed **?**”
WIC and operating vacuum is weak
after manual pulse cleaning, remove
the metal filter, clean with
compressed air and re-install.
7. If vacuum remains weak after
cleaning the metal filter, contact
AVANI for filter replacement. (See
contact list in this manual).

AVANI Top Mounted Dust Collector

Dimensions (in mm/inches)

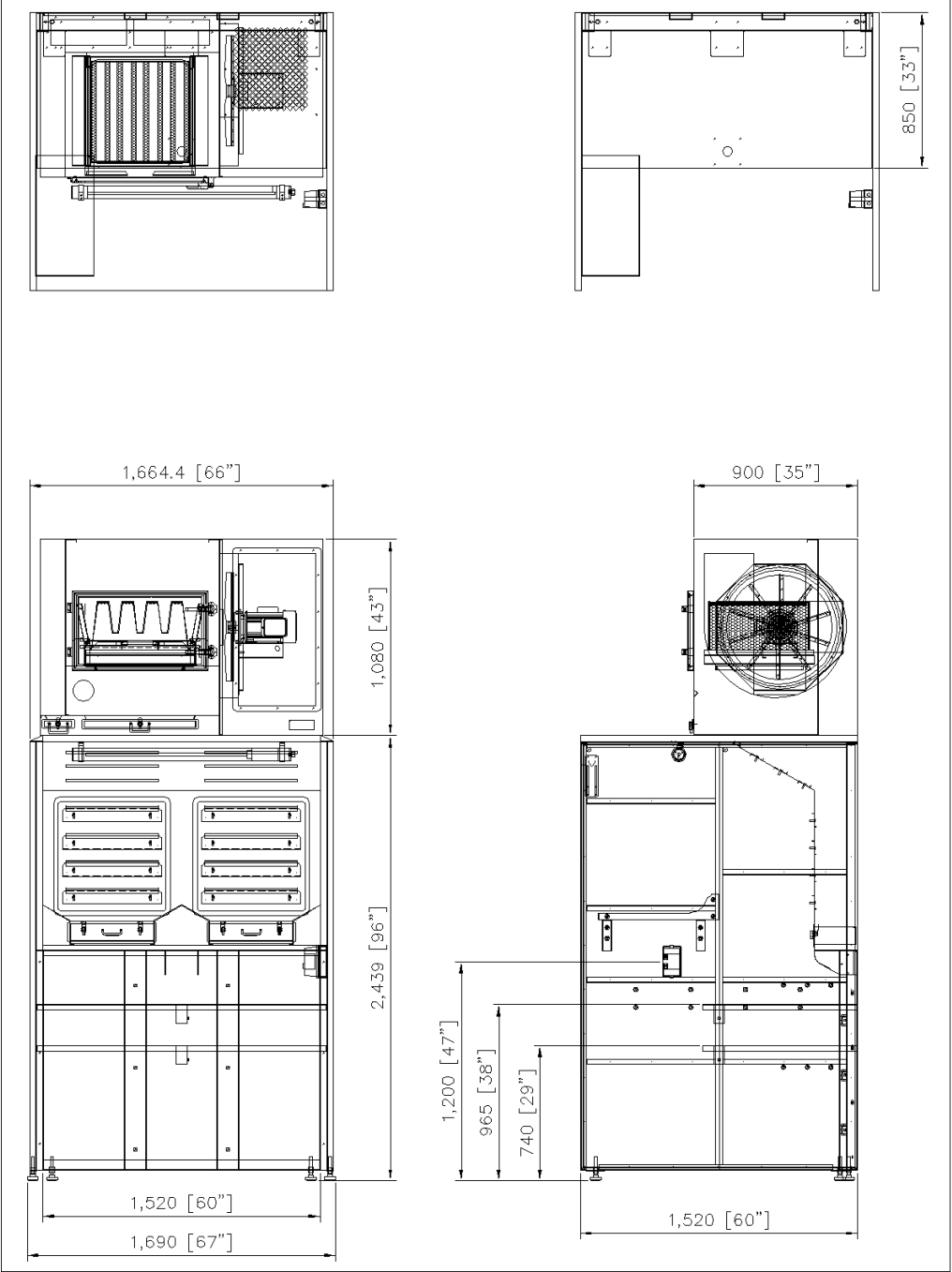

AVANI Top Mounted Dust Collector

Filters

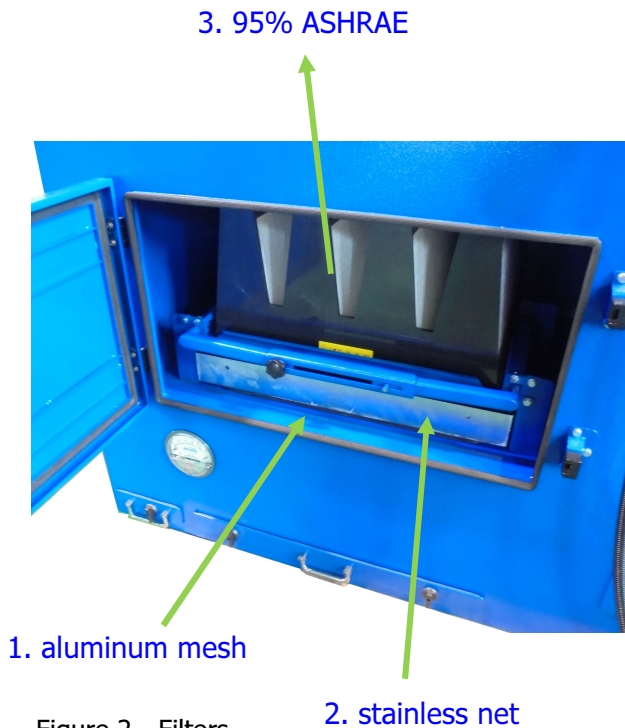

1. **ALUMINUM MESH** captures sparks and steel chips.

(1) specification: 485 x 485 x 22 mm
[19.1" x 19.1" x 0.87"]

(2) required quantity: 1 pcs

(3) filter efficiency: 25 ~ 30%

2. **STAINLESS NET** captures up to 95% of the sparks and steel chips down to 1 – 2 micron.

(1) specification: 600 x 600 x 50 mm
[23.6 x 23.6 x 2.04 inch]

(2) quantity: 1 pc

(3) filter efficiency: 5%

3. **95% ASHRAE FILTER** cleans noxious fumes to provide a better working environment.

(1) specification: 595 x 595 x 300 mm
[24.3" x 24.3" x 11.91"]

(2) quantity: 1 set

filter efficiency: 95%

Filter Assembly

• Aluminum mesh:

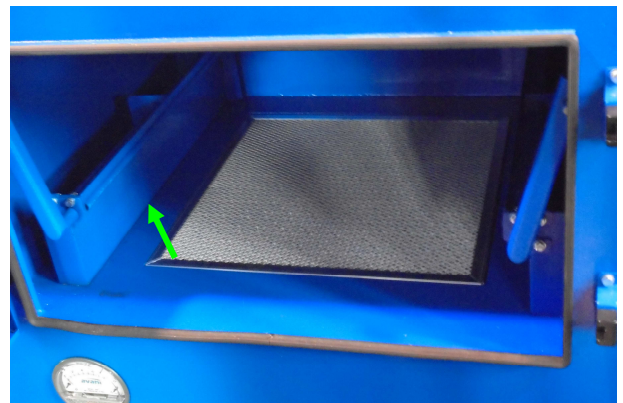

1. Pull out the aluminum mesh and dispose it away. Install with a new one.

• Cartridge filter installation procedure:

AVANI Top Mounted Dust Collector



1. Open the front maintenance door of the top mounted dust collector.

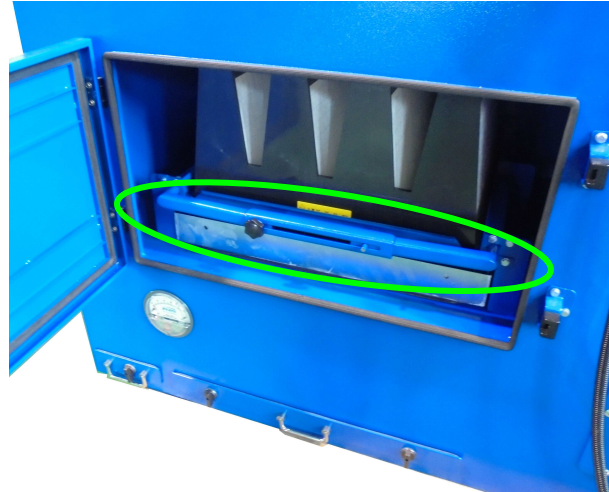

2. Loosen the knobs (circled in green). Release the filter handle fixing plates. Slide the filter handle fixing plates.

AVANI Top Mounted Dust Collector

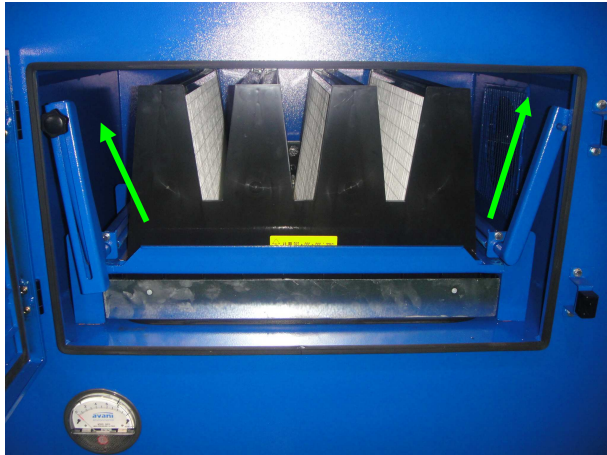

3. Pull up the left and right filter handles.

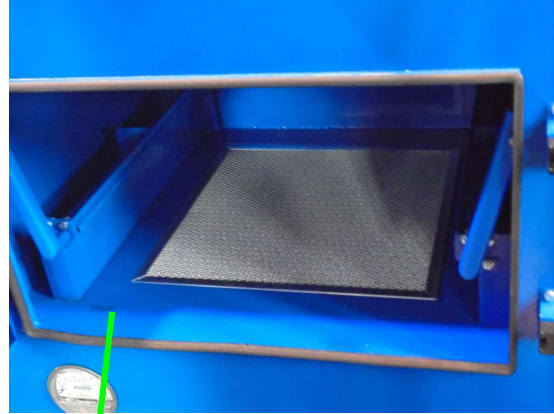

5. Pull out the filter.



4. Pull out the filter set

6. Take out the filter set and install with a new filter.

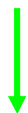

AVANI Top Mounted Dust Collector

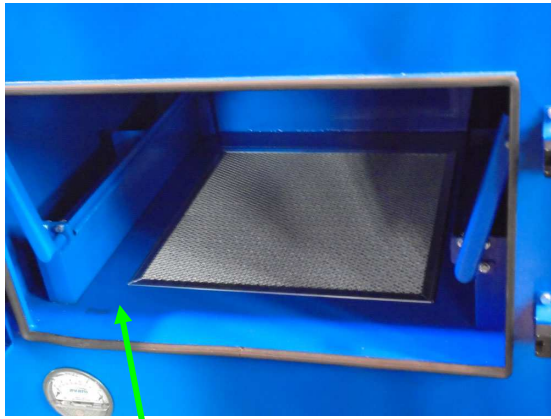

7. Slide the new filter into the track and push it to the end.

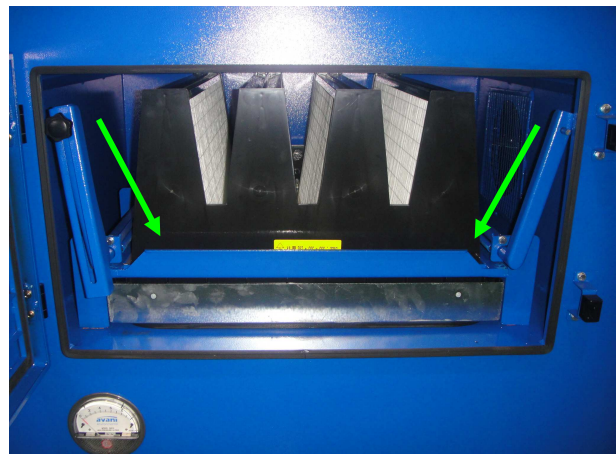
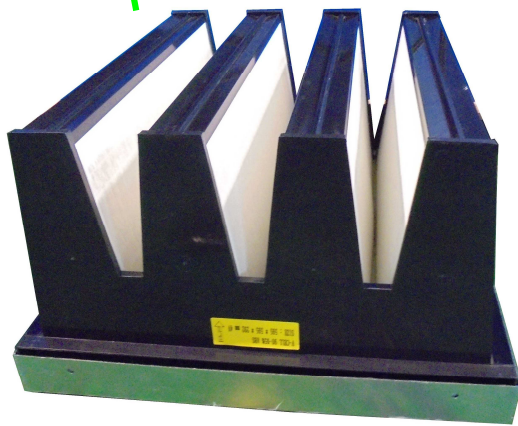

8. Pull down the left and right filter handles.

AVANI Top Mounted Dust Collector

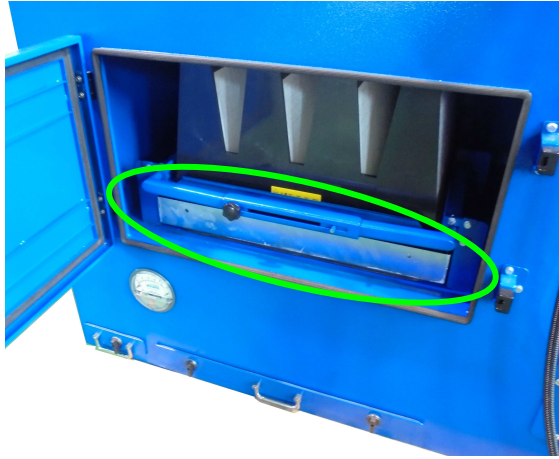

9. Attach the filter handle fixing plate upon the left and right filter handles. Slide and secure them in position. Fasten the plates and handles with knobs (circled in green).



10. Close the front maintenance door of the top mounted dust collector. Assembly completed.

AVANI Top Mounted Dust Collector

Repair Parts Illustration and Repair Parts List
For Repair Parts, call +1-919-570-2862
24 hours a day – 365 days a year

Please provide following information:

- Model number
- Serial number (if any)
- Part description and number as shown in parts list

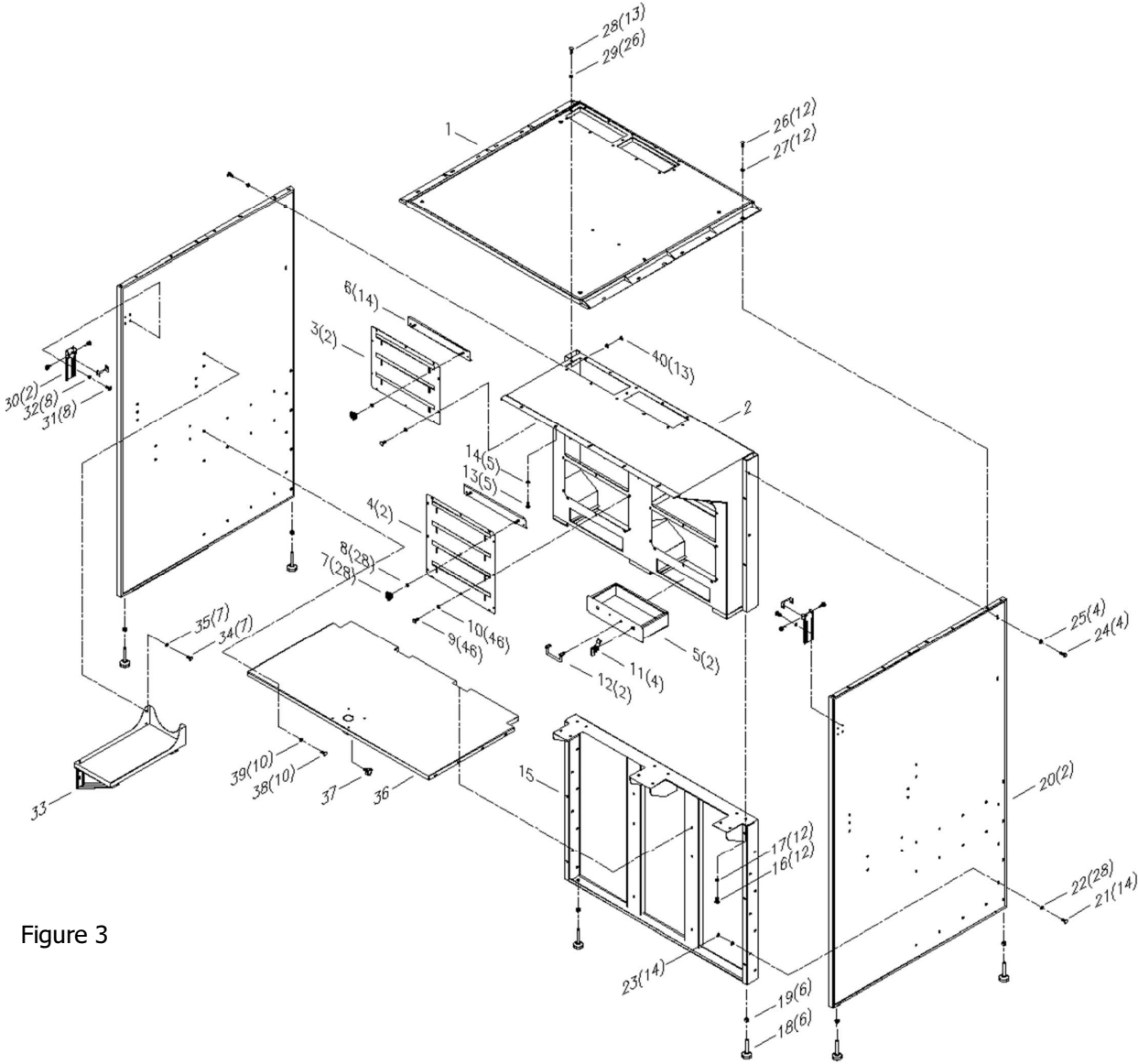

Figure 3



AVANI Top Mounted Dust Collector

Repair Parts List

Reference Number	Description	Part Number	Quantity
1	Top Hood Draft	A02-01-WB-55S-1	1
2	Backdraft Module - Top	A02-01-WB-55S-2	1
3	Slot Cover - small	A02-01-WB-55S-3	2
4	Slot Cover	A02-01-WB-55S-4	2
5	Clean Out Drawer	A02-01-WB-55S-5	2
6	Backdraft Module - Slot Cover	A02-01-WB-55S-6	14
7	Knob Screw 3/8"	A02-01-WB-55S-7	28
8	Flat Washer (3/8"/OD23*2t)	A02-01-WB-55S-8	28
9	Hex Screw (5/16"*3/4")	A02-01-WB-55S-9	46
10	Flat Washer (5/16"/OD23*2t)	A02-01-WB-55S-10	46
11	Drawer Lock	A02-01-WB-55S-11	2
12	Drawer Handle	A02-01-WB-55S-12	2
13	Hex Screw (5/16"*3/4")	A02-01-WB-55S-13	5
14	Flat Washer (3/8"/OD23*2t)	A02-01-WB-55S-14	5
15	Backdraft Module - Down	A02-01-WB-55S-15	1
16	Hex Screw (5/16"*3/4")	A02-01-WB-55S-16	12
17	Flat Washer (5/16"/OD23*2t)	A02-01-WB-55S-17	12
18	Adjustable Feet	A02-01-WB-55S-18	6
19	Hex Nut M16	A02-01-WB-55S-19	6
20	Side Panel	A02-01-WB-55S-20	2
21	Half-threaded Screw 3/8"*4"	A02-01-WB-55S-21	14
22	Flat Washer (3/8"/OD23*2t)	A02-01-WB-55S-22	28
23	Nylon Hex Nut 3/8"	A02-01-WB-55S-23	14
24	Hex Screw (5/16"*2-1/2")	A02-01-WB-55S-24	4

AVANI Top Mounted Dust Collector

Reference Number	Description	Part Number	Quantity
25	Flat Washer (5/16"/OD23*2t)	A02-01-WB-55S-25	4
26	Hex Screw (5/16"*3/4")	A02-01-WB-55S-26	12
27	Flat Washer (5/16"/OD23*2t)	A02-01-WB-55S-27	12
28	Half-threaded Screw 3/8"*3"	A02-01-WB-55S-28	13
29	Flat Washer (3/8"/OD23*2t)	A02-01-WB-55S-29	26
30	Adjustable Curtain Rods	A02-01-WB-55S-30	2
31	Hex Screw (1/4"*3/4")	A02-01-WB-55S-31	8
32	Flat Washer (1/4"/OD19*2t)	A02-01-WB-55S-32	8
33	Co2 Bracket (left)	A02-01-WB-55S-33	1
34	Hex Screw (5/16"*3/4")	A02-01-WB-55S-34	7
35	Flat Washer (5/16"/OD23*2t)	A02-01-WB-55S-35	7
36	Table	A02-01-WB-55S-36	1
37	Knob Screw 5/16"*3/4"	A02-01-WB-55S-37	1
38	Hex Screw (5/16"*3/4")	A02-01-WB-55S-38	10
39	Flat Washer (5/16"/OD23*2t)	A02-01-WB-55S-39	10
40	Nylon Hex Nut 5/16"	A02-01-WB-55S-40	13

AVANI Top Mounted Dust Collector

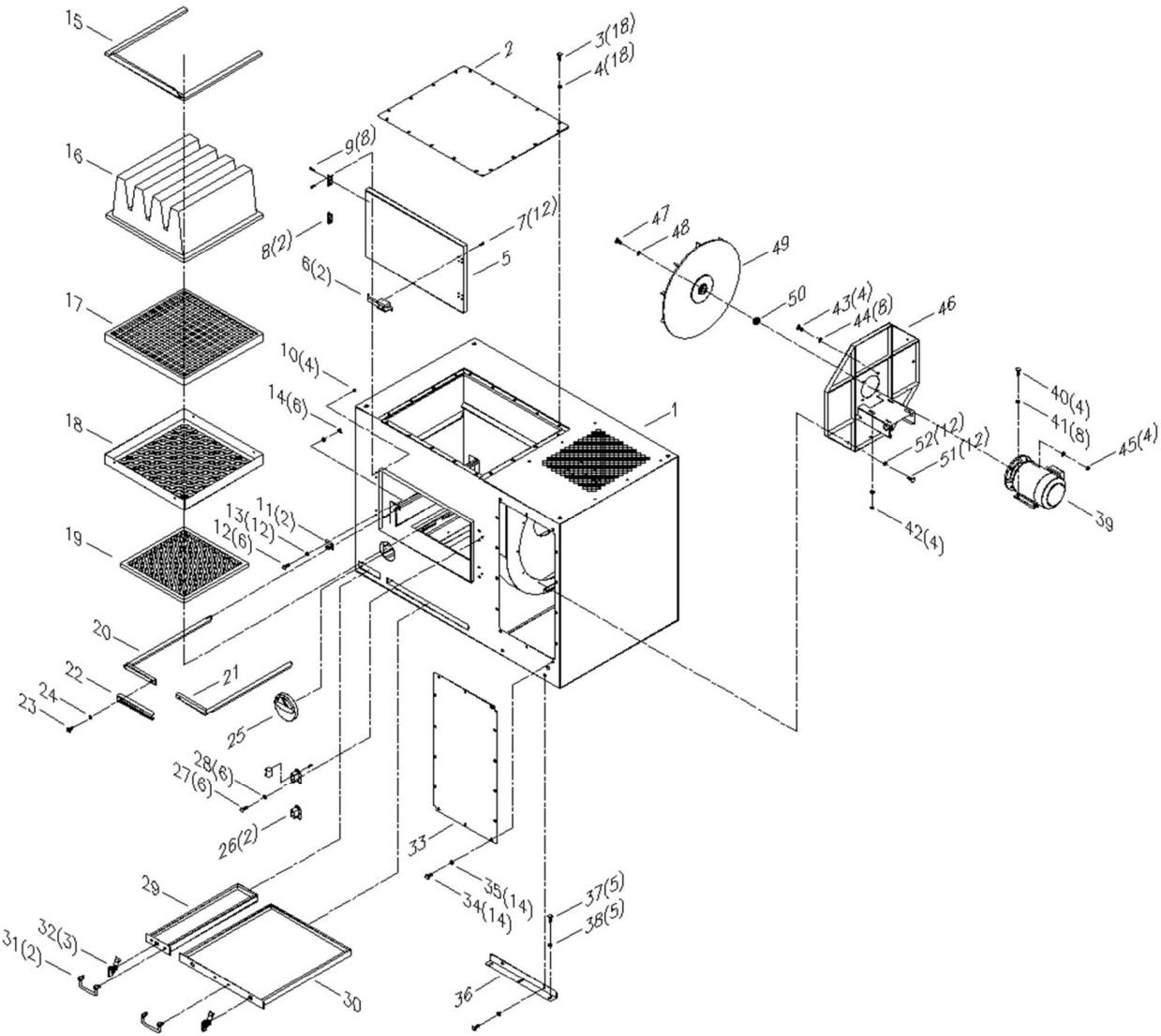

AVANI Top Mounted Dust Collector

Repair Parts List for Top Mount Dust Collector

Reference Number	Description	Part Number	Quantity
1	Main Body	A02-01-SDC-B-HEPA-1	1
2	Seal Cover (upper)	A02-01-SDC-B-HEPA-2	1
3	Hex Screw 5/16"*3/4"	A02-01-SDC-B-HEPA-3	18
4	Flat Washer 5/16"/OD23*2t	A02-01-SDC-B-HEPA-4	18
5	Door	A02-01-SDC-B-HEPA-5	1
6	Compression Latch	A02-01-SDC-B-HEPA-6	2
7	Countersunk Inner Hex Screw M5*14	A02-01-SDC-B-HEPA-7	12
8	Hinge	A02-01-SDC-B-HEPA-8	2
9	Countersunk Inner Hex Screw M5*14	A02-01-SDC-B-HEPA-9	8
10	Flange Nut M5	A02-01-SDC-B-HEPA-10	4
11	Gusset	A02-01-SDC-B-HEPA-11	2
12	Hex Screw 1/4"/3/4"	A02-01-SDC-B-HEPA-12	6
13	Flat Washer 1/4"*OD19*2t	A02-01-SDC-B-HEPA-13	12
14	Hex Nut 1/4"	A02-01-SDC-B-HEPA-14	6
15	Filter a frame	A02-01-SDC-B-HEPA-15	1
16	HEPA filter	A02-01-SDC-B-HEPA-16	1
17	STAINLESS NET	A02-01-SDC-B-HEPA-17	1
18	Filter Cover	A02-01-SDC-B-HEPA-18	1
19	Aluminum Mesh	A02-01-SDC-B-HEPA-19	1
20	Filter Handle(left)	A02-01-SDC-B-HEPA-20	1
21	Filter Handle(right)	A02-01-SDC-B-HEPA-21	1
22	Filter Handle Fixing Plate	A02-01-SDC-B-HEPA-22	1
23	Knob 5/16"x3/4"	A02-01-SDC-B-HEPA-23	1

AVANI Top Mounted Dust Collector

Reference Number	Description	Part Number	Quantity
24	Flat Washer 5/16"xOD18x2t	A02-01-SDC-B-HEPA-24	1
25	Pressure Gauge	A02-01-SDC-B-HEPA-25	1
26	Compression Latch Base	A02-01-SDC-B-HEPA-26	2
27	Hex Screw 5/16"*3/4"	A02-01-SDC-B-HEPA-27	6
28	Flat Washer 5/16"/OD23*2t	A02-01-SDC-B-HEPA-28	6
29	Drawer (small)	A02-01-SDC-B-HEPA-29	1
30	Drawer (large)	A02-01-SDC-B-HEPA-30	1
31	Handle	A02-01-SDC-B-HEPA-31	2
32	Drawer Lock	A02-01-SDC-B-HEPA-32	3
33	Seal Board	A02-01-SDC-B-HEPA-33	1
34	Hex Screw 5/16"*3/4"	A02-01-SDC-B-HEPA-34	14
35	Flat Washer 5/16"/OD23*2t	A02-01-SDC-B-HEPA-35	14
36	Fixing Base	A02-01-SDC-B-HEPA-36	1
37	Hex Screw 5/16"*3/4"	A02-01-SDC-B-HEPA-37	5
38	Flat Washer 5/16"/OD23*2t	A02-01-SDC-B-HEPA-38	5
39	MOTOR	A02-01-SDC-B-HEPA-39	1
40	Hex Screw 5/16"*1"	A02-01-SDC-B-HEPA-40	4
41	Flat Washer 5/16"/OD23*2t	A02-01-SDC-B-HEPA-41	8
42	Nylon Hex Nut 5/16"	A02-01-SDC-B-HEPA-42	4
43	Hex Screw 3/8"x1-1/2"	A02-01-SDC-B-HEPA-43	4
44	Flat Washer 3/8"xOD28x2.5t	A02-01-SDC-B-HEPA-44	8
45	Nylon Hex Nut 3/8"	A02-01-SDC-B-HEPA-45	4
46	MOTOR Base	A02-01-SDC-B-HEPA-46	1
47	Hex Screw M8*20L	A02-01-SDC-B-HEPA-47	1
48	Flat Washer 5/16"/OD23*2t	A02-01-SDC-B-HEPA-48	1
49	Impeller	A02-01-SDC-B-HEPA-49	1

AVANI Top Mounted Dust Collector

Reference Number	Description	Part Number	Quantity
50	Impeller Washer	A02-01-SDC-B-HEPA-50	1
51	Hex Screw 5/16"*3/4"	A02-01-SDC-B-HEPA-51	12
52	Flat Washer 5/16"/OD23*2t	A02-01-SDC-B-HEPA-52	12

AVANI Top Mounted Dust Collector

Appendix 1 - Electrical Circuit Diagram

1.5HP/120V/60HZ/1PH

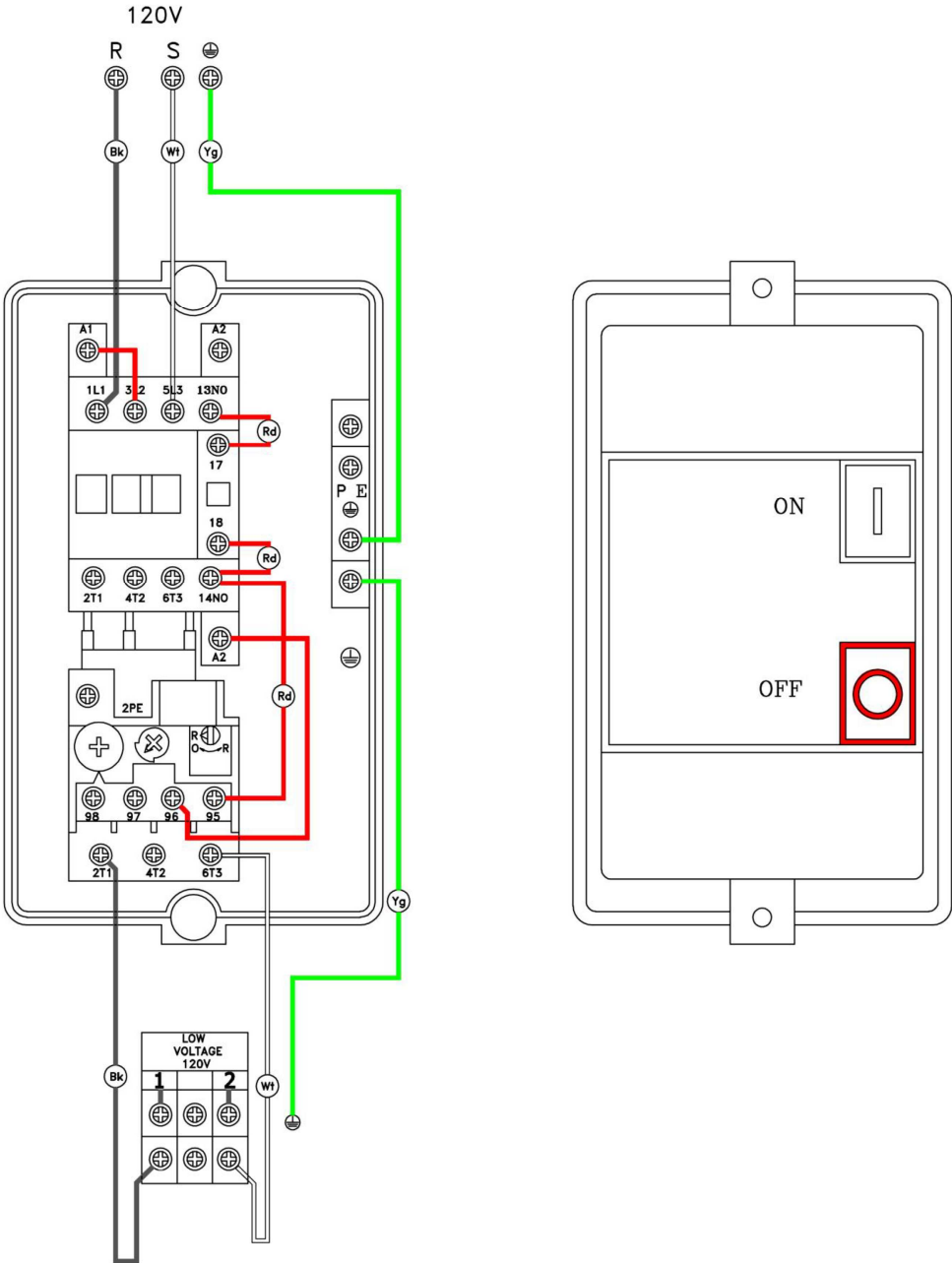

AVANI Top Mounted Dust Collector

1.5HP/120V/60HZ/1PH

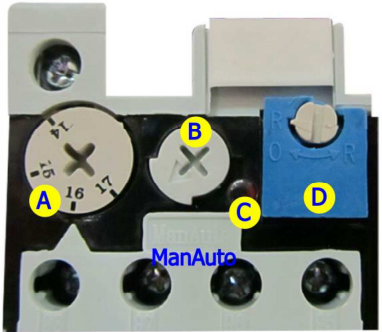
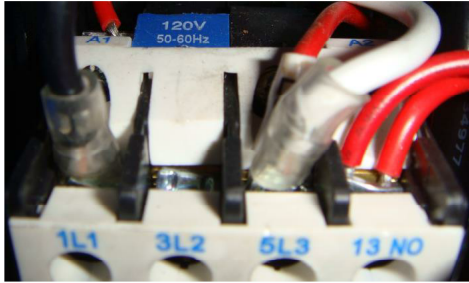
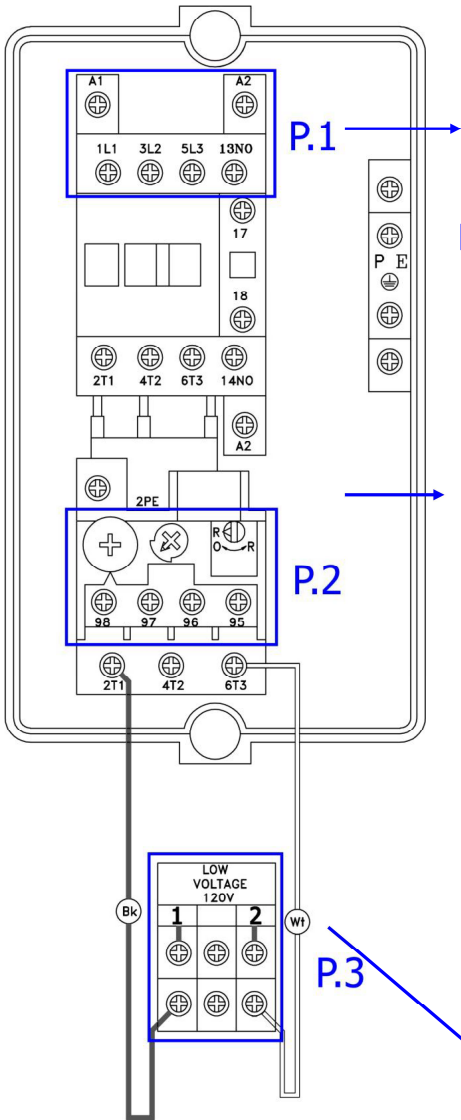

- ◆ A: Setting current button.
- ◆ B: Setting lever Man & Auto button.
- ◆ C: Switching position indication
- ◆ D: Button for reset and disconnection-setting: O/RorR; O/R=reset and disconnection R=reset only



AVANI Top Mounted Dust Collector

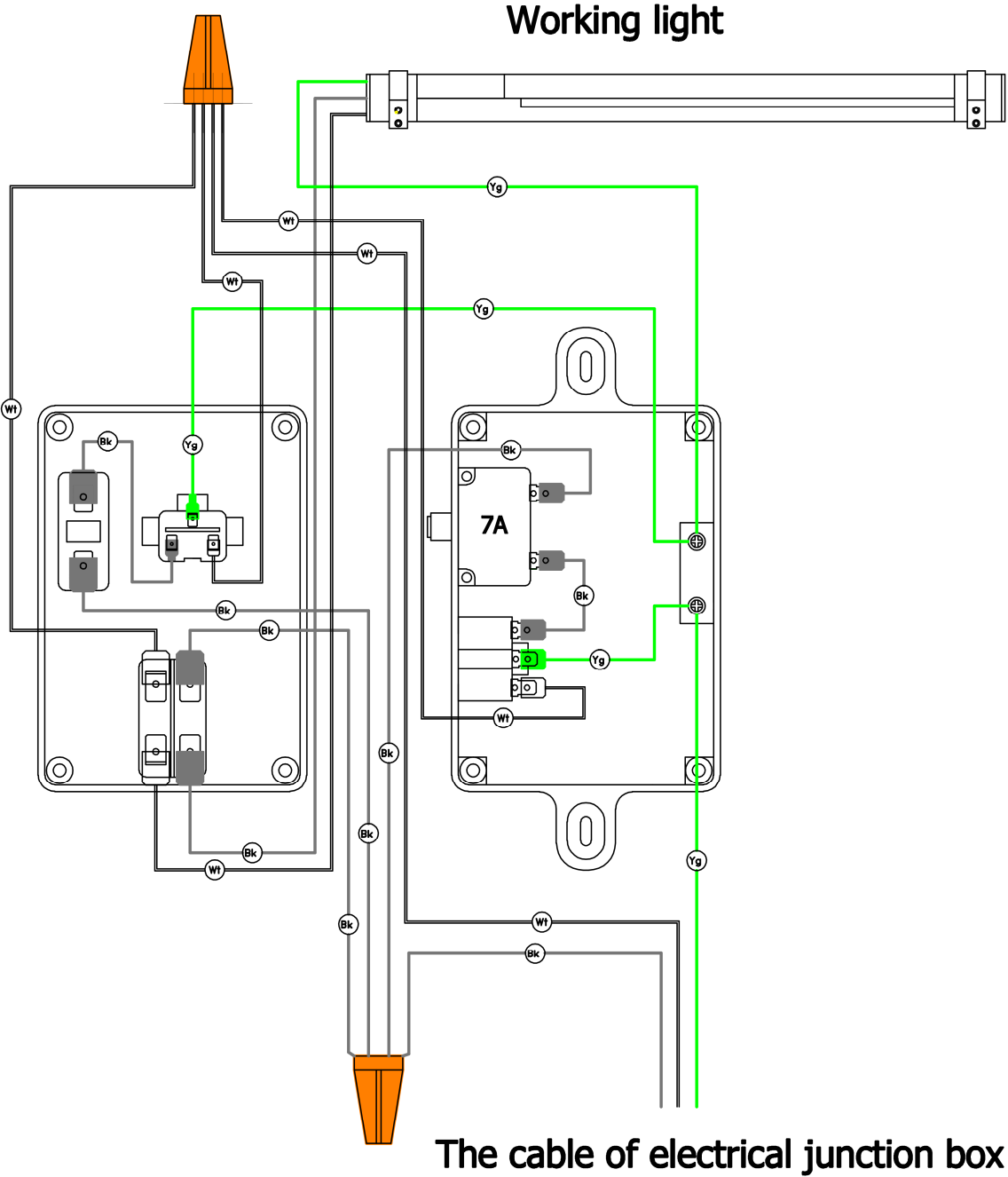

AVANI Top Mounted Dust Collector

Contact Information

Avani Environmental International Inc.

95 Cypress Drive,

Youngsville, NC 27596

Email: info@avanienvironmental.com

www.avanienvironmental.com

Customer Service: info@avanienvironmental.com

Tel: 919-570-2862 ext.5167

Engineering Service: engineering@avanienvironmental.com

Tel: 919-570-2862 ext.5162