

Great Lakes Machinery SO21478

Duct Layout

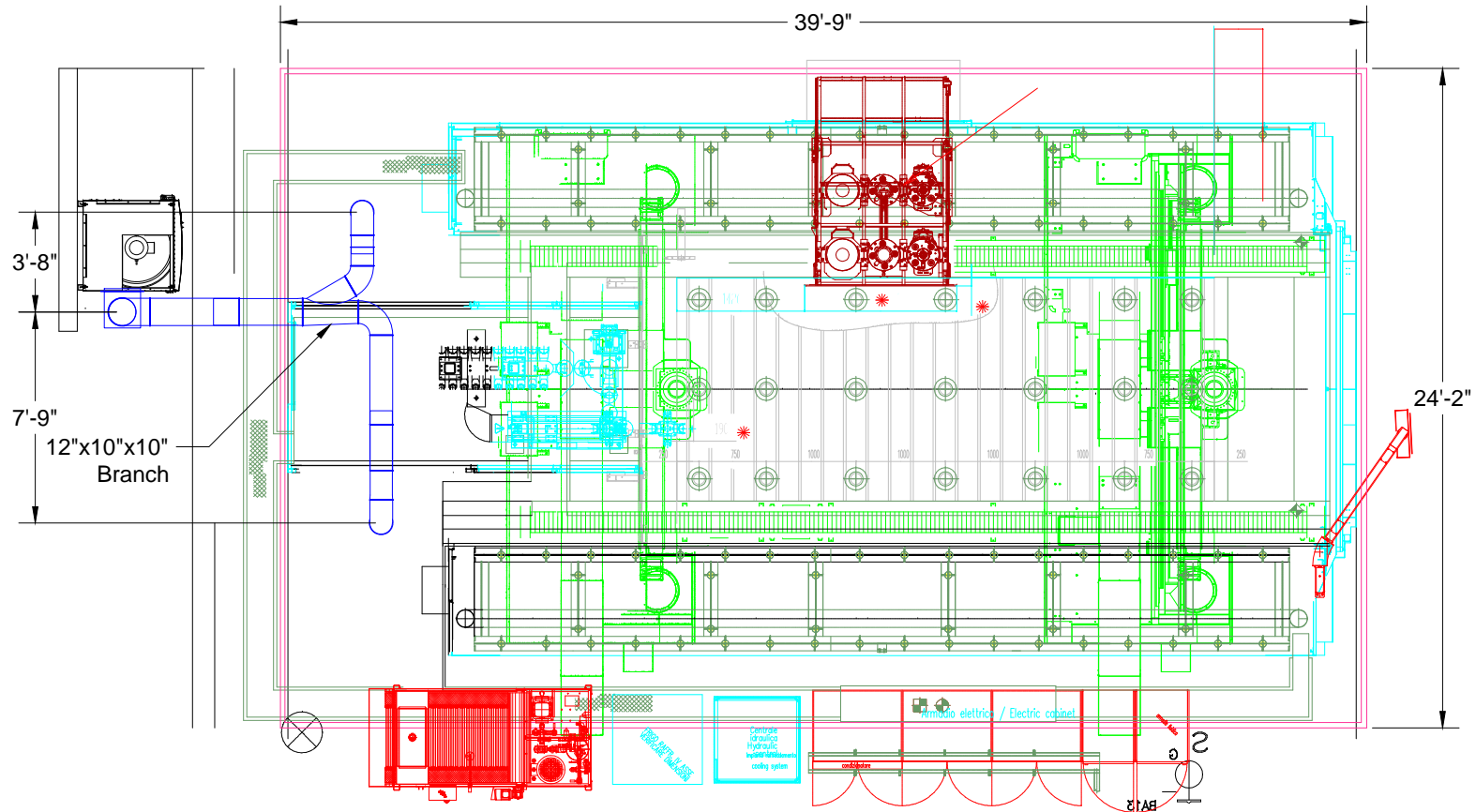

Plan View

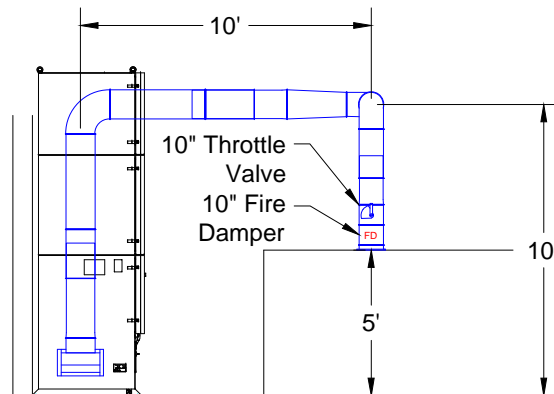

Elevation View

Notes:

1. Duct to connect to CNC Machine
2. Avani Environmental standard installation crew is quoted out per day based on the above drawings and approvals. Any changes, modifications, downtime, or inability to perform our work above and beyond the control of Avani Environmental will charge an additional \$1,000 per work day (5 or more hours) per crew above what was initially quoted.

Avani Environmental Intl. Inc.
 95 Cypress Drive
 Youngsville, NC 27596
 P# 919-488-2862 F# 919-488-2863

Avani

Project: Great Lakes Machinery SO21478

Drawing: Approval Drawing

Date: 6/6/14

Drawn by: MDT

Sheet No: 1 OF 1

Rev: 0