

DO NOT SCALE

IF IN DOUBT ASK

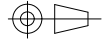

Revisions

Rev	Description	Date	Approved
-----	-------------	------	----------

Hanging Arm 8"x10'

Diameter: 8"

Length: 10'

Weight: 46.3 lbs (net)

Arm Construction: Two galvanized steel tubes, three pieces of flex hose at joints, aluminum hood, heavy gauge steel swivel base, and support spring.

Arm Adjustment: Externally supported, adjustments are quickly done at the joints.

Hood: 14" diameter round aluminum hood.

Damper: Internal with external adjustment.

Finish: Powder coated.

Hose: Rated at 200 F

Accessories: Mounting bracket and light kit.

Mounting Bracket:

Warranty: Limited two years from date of purchase.

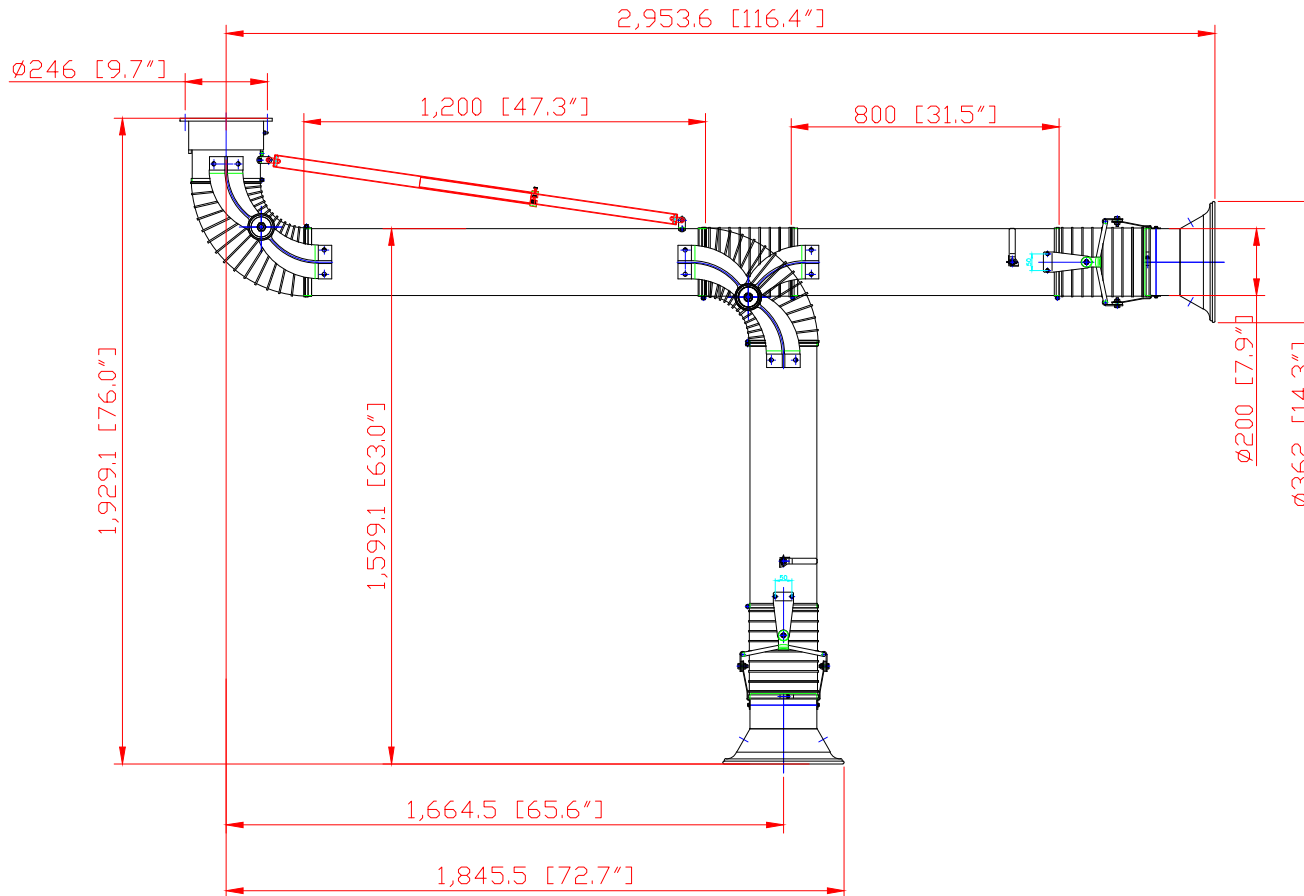

Packing Size:	165 x 101.5 x 39 cm 65 x 40 x 15.4 inch
N.W. / G.W.:	21 / 34 kgs 46.3 / 75 lbs

Drawing Number 22087.8

Avani Environmental Intl. Inc.
95 Cypress Drive
Youngsville, NC 27596
sales@avanienvironmental.com

Sales Department
(919) 570-2862

	Date	Name	Part Number:
Drawn by:	2012-03-01	DOJ	PART NO.
Checked by:			

This drawing is confidential and is the exclusive property of Avani Environmental Intl. Inc. No unauthorized use/copy or disclosure is to be made and it is returned whenever required.

Title:		
Arm 2030		
Size	Scale	Drawing Number:
A	1 = xx	2009.12.08