

DO NOT SCALE

IF IN DOUBT ASK



Revisions

Rev	Description	Date	Approved
-----	-------------	------	----------

top view

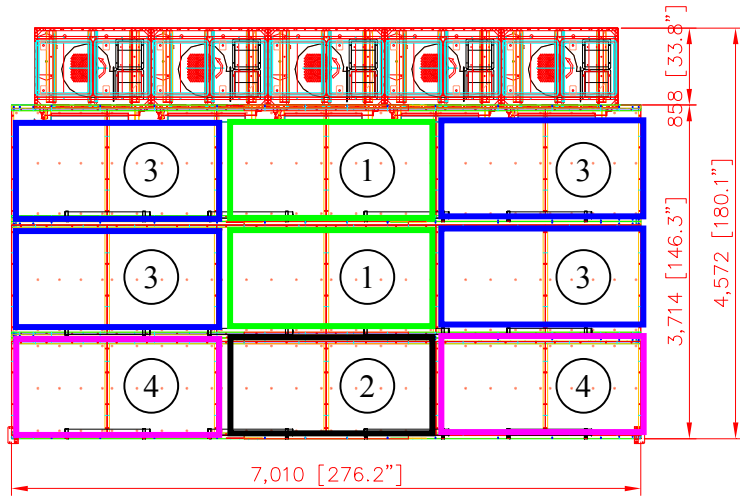

2010.06.30

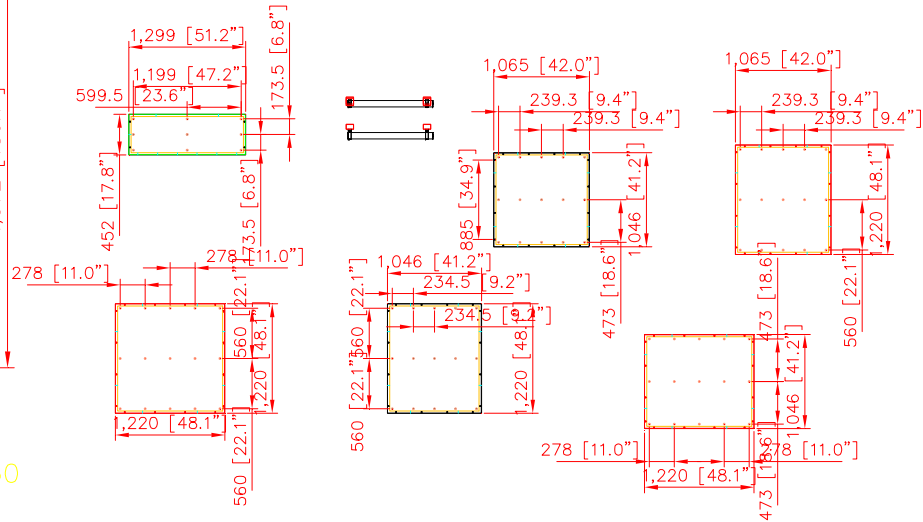

front view

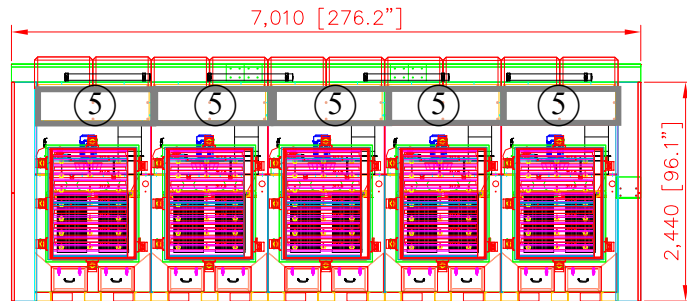

side view

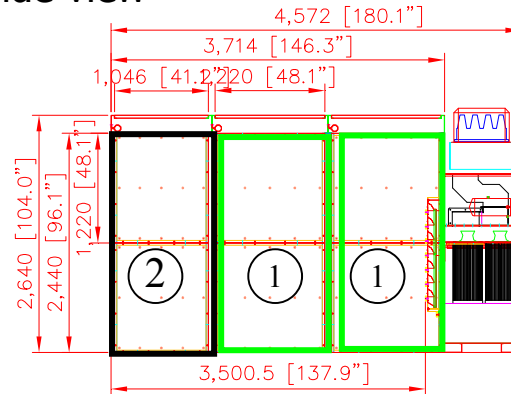

OSKAR ENVIRONMENTAL, INC.
 95 Cypress Drive
 Youngsville, NC 27596

Sales Department
 (919) 570-2862
 sales@oskarsales.com

Drawn by:	Date	Name	Part Number:	Title:
Checked by:	2010-06-30	XXXXX	Fleet Readiness Center East Cherry Point	Environmental Booth

This drawing is confidential and is the exclusive property of Oskar Environmental. No unauthorized use/copy or disclosure is to be made and it is returned whenever required.

Size	Scale	Drawing Number:
B	1 = 35	***

sound insulation panels= 24 pcs

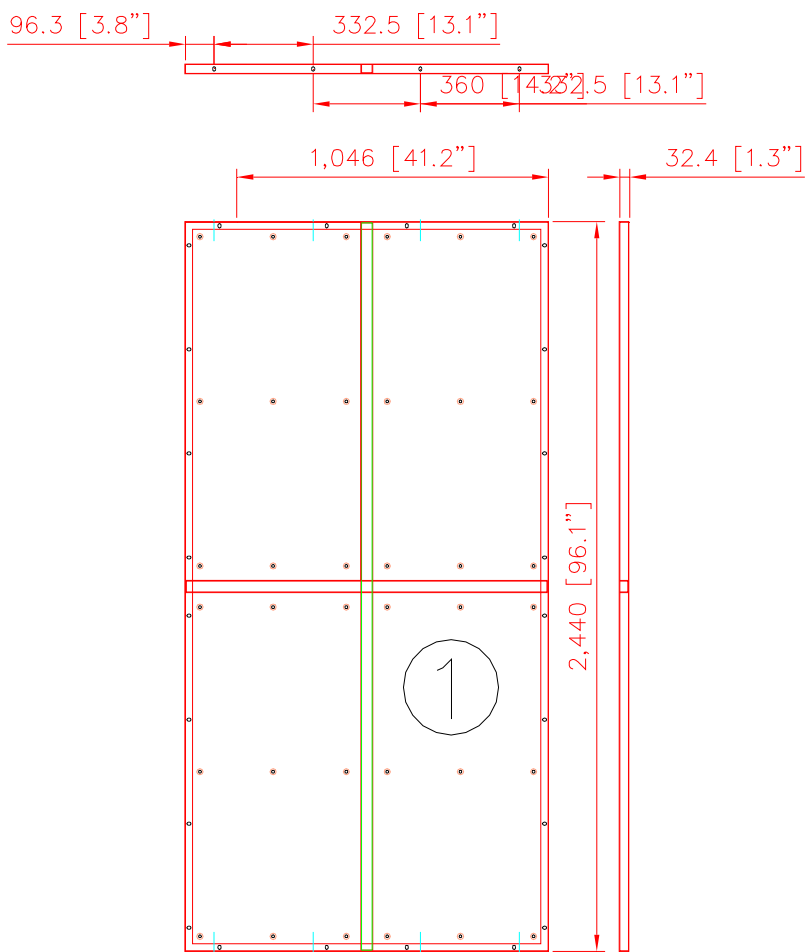
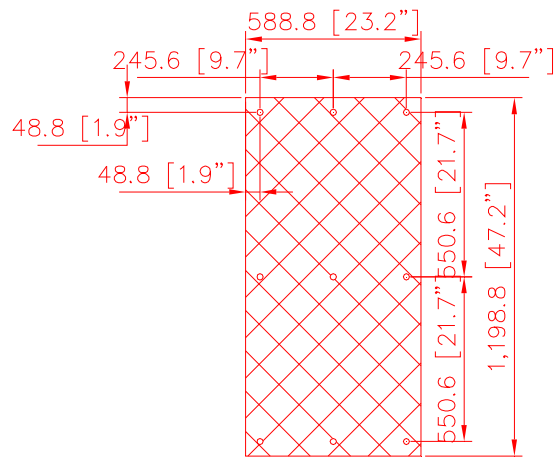

① : 6 pcs

sound insulation panels=12 pcs

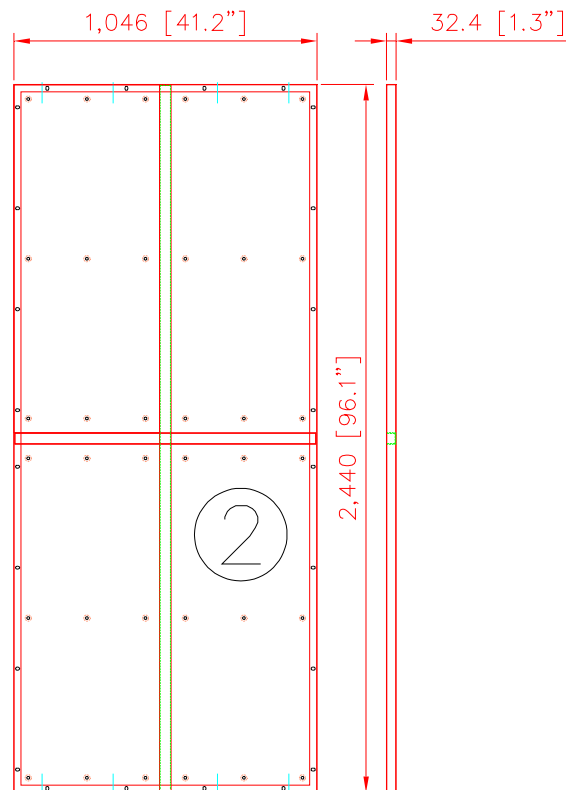
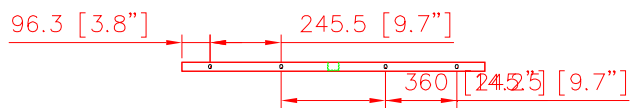
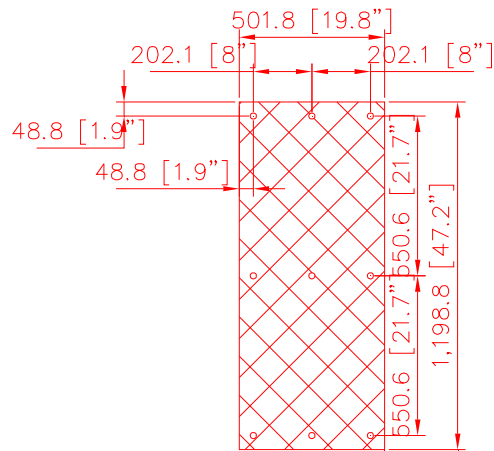

② : 3 pcs

sound insulation panels=16 pcs

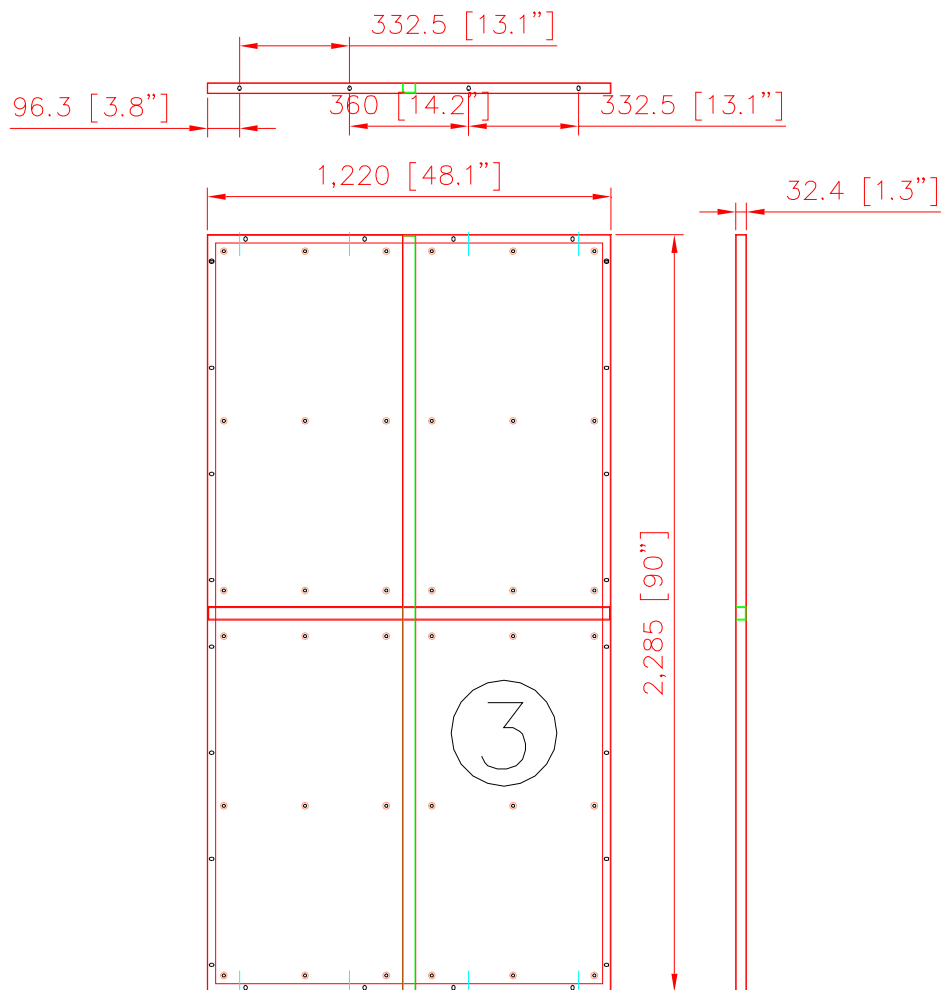
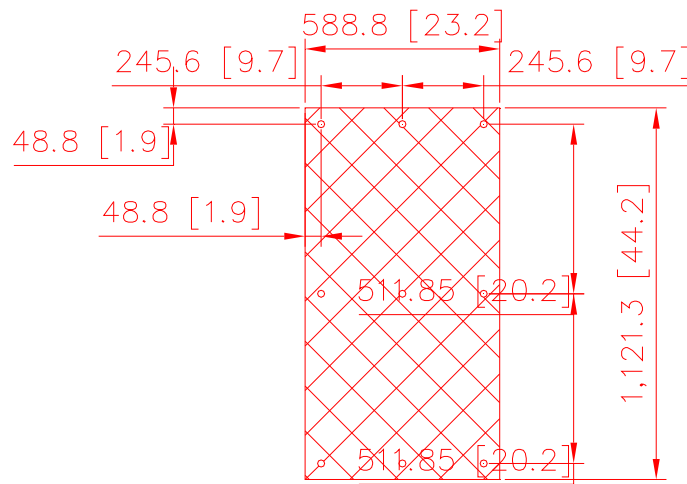

③ : 4 pcs

sound insulation panels=8 pcs

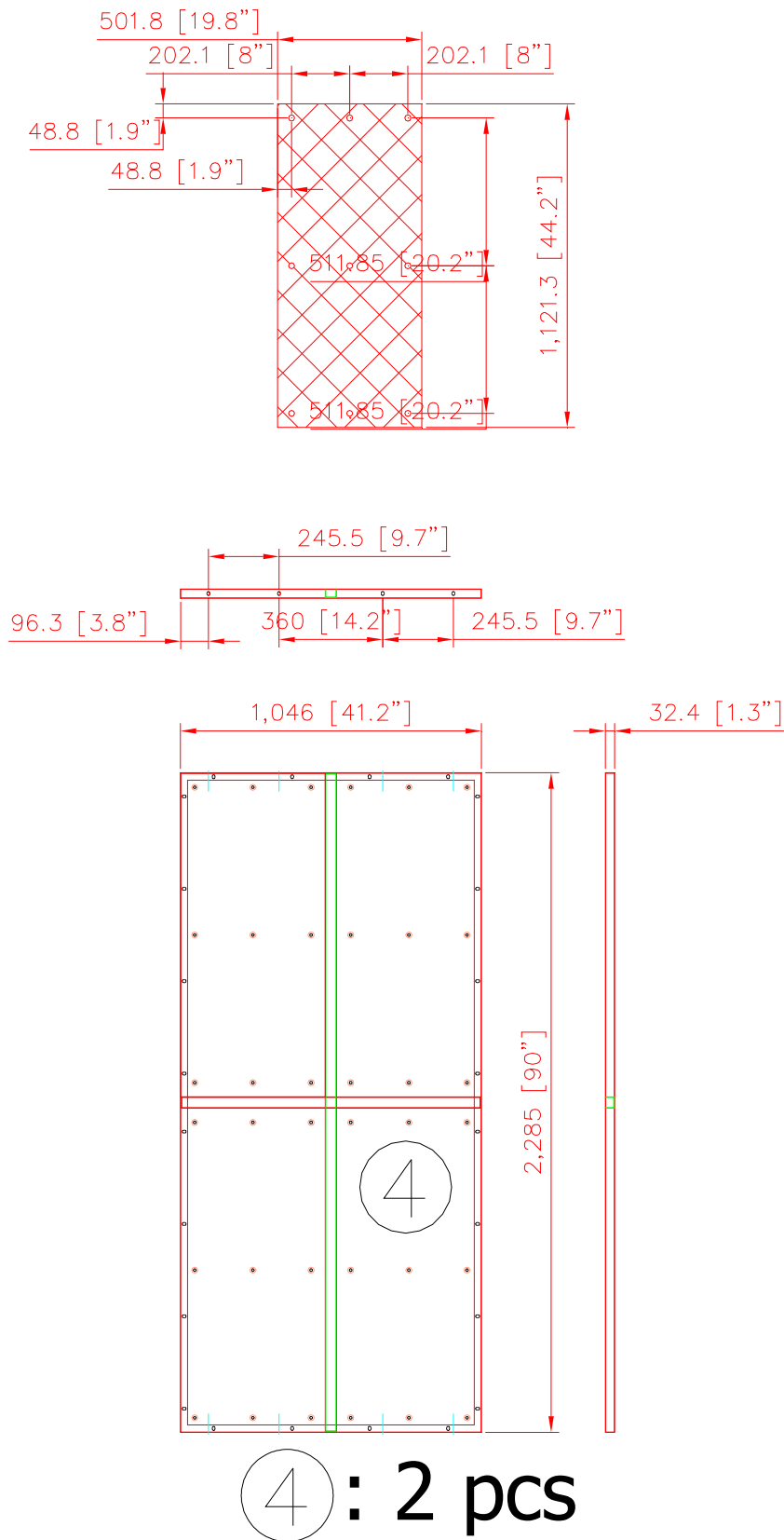

sound insulation panels=5 pcs

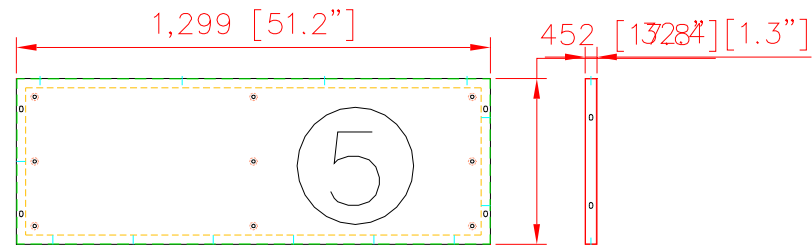
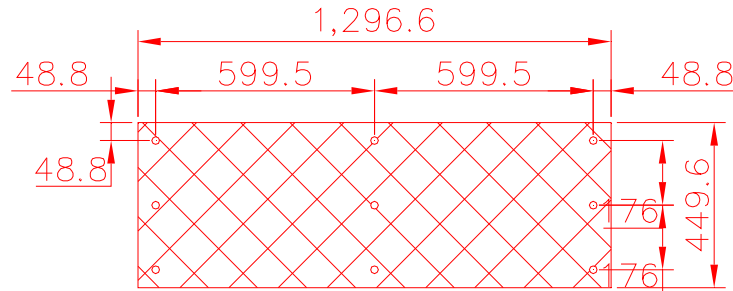

⑤ : 5 pcs

