

DO NOT SCALE

IF IN DOUBT ASK



Revisions

Rev	Description	Date	Approved

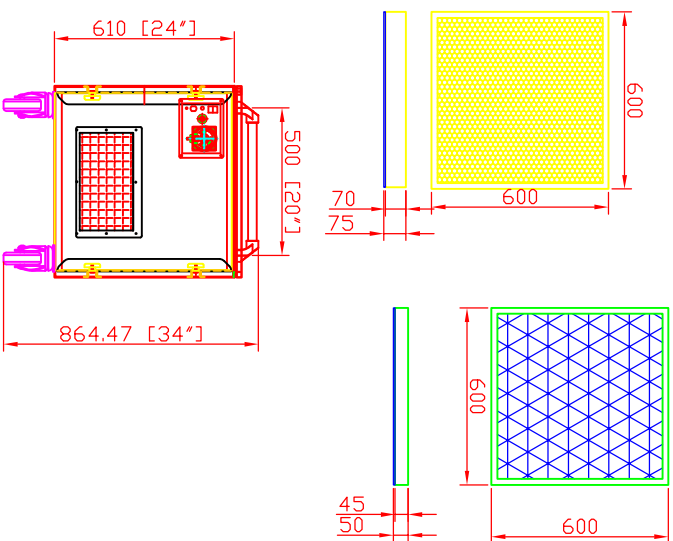
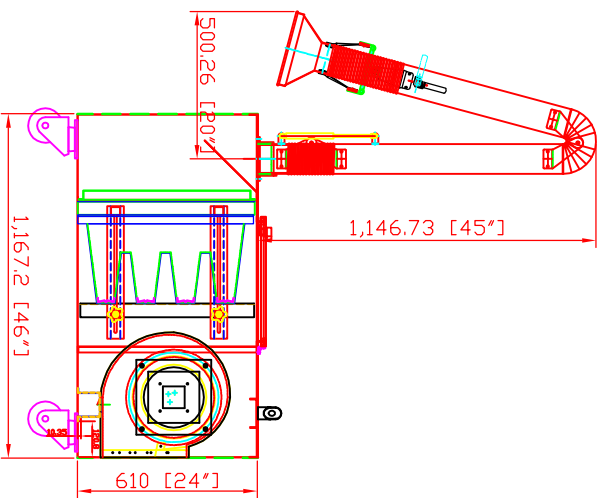
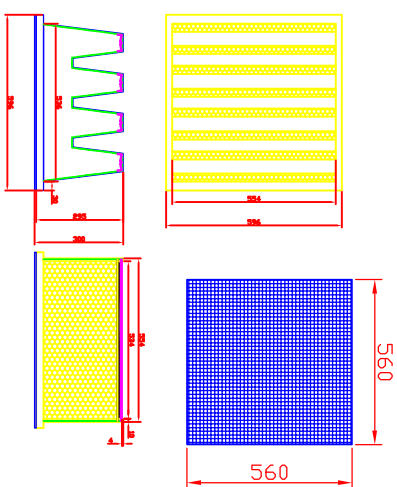
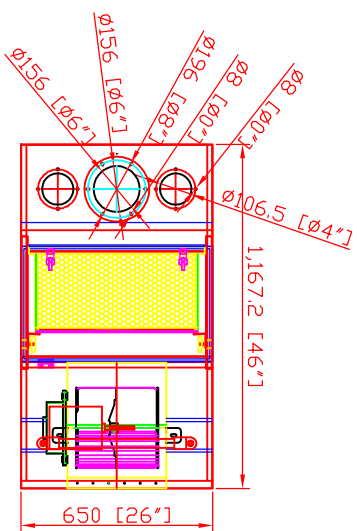

PORTABLE HEPA COLLECTOR SPECIFICATIONS

Motor: 860W

Voltage: 120V / 60Hz / 1Ph

Air Volume (C.F.M.) : 800 Ft³/Min (23 M³/Min)

Inlet Size: Ø 6" (150 mm) or Ø 4" x 2 (101.6 mm)

Packing Size (L x W x H): 50" x 29.2" x 40.6" (127 x 74 x 103 cm)

Net Weight: 220.5lbs (100 kgs)

Gross Weight: 308.6 lbs (140 kgs)-

Filtration Stages:

1. stainless net
 - spec: 600 x 600 mm (23.6" x 23.6")
 - required quantity: 1 pc
2. pre-pleated filter
 - spec: 595 x 595 x 45mm (23.4" x 23.4" x 1.8")
 - filter efficiency: 35%
 - required quantity: 1 pc
3. HEPA filter
 - spec: 600 x 600 x 305 mm (24" x 24" x 11.5")
 - filter efficiency: 95%
 - required quantity: 1 pc

***casters underneath the machine

***ARM 1020P shown in this drawing

AVANI ENVIRONMENTAL INTL. INC. Sales Department
95 Cypress Drive
Youngsville, NC 27596

(919) 570-2862

info@avanienvironmental.com

Drawn by:	Date	Name
2014-10-24		***

Checked by:	Date	Name

Part Number:
REVISION II

Title:

SPC-800 w/ ARM 1020P

Size Scale

A 1 = 20

Drawing Number:

The drawings, AutoCAD, 3-D Models, and specifications are the property of Avani Environmental Intl. Inc. (AE) and may not be reproduced, distributed, modified, or otherwise used, except provided herein, without the express written permission of AE.