

REV.	DESCRIPTION	DATE	APPROVED

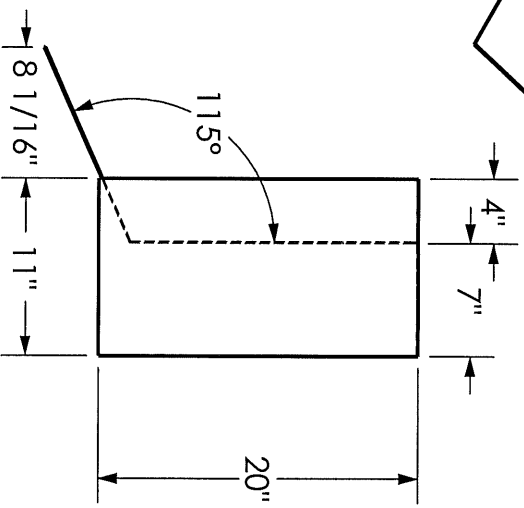
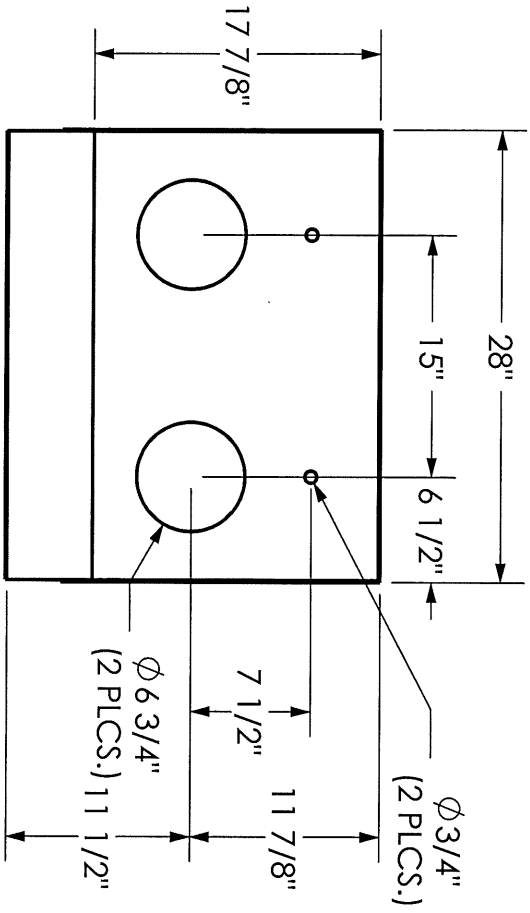
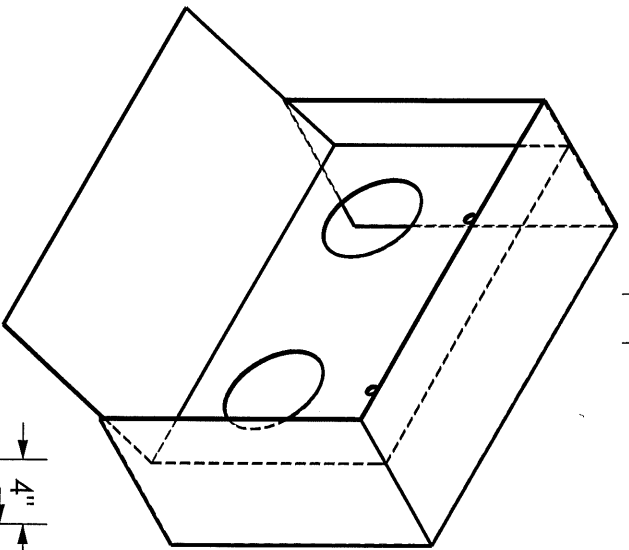
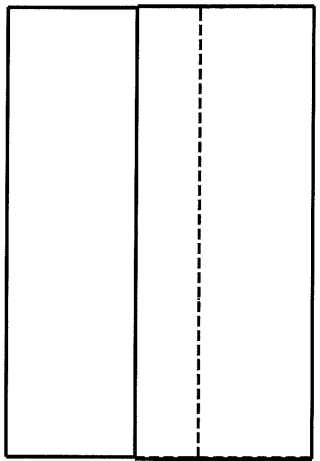

QTY. 3

**PROPRIETARY AND CONFIDENTIAL**  
 THE INFORMATION CONTAINED IN THIS DRAWING IS THE SOLE PROPERTY OF BONNEY FORGE. ANY REPRODUCTION IN PART OR AS A WHOLE WITHOUT THE WRITTEN PERMISSION OF BONNEY FORGE IS PROHIBITED.

DIMENSIONS ARE IN INCHES		NAME	DATE	<b>BONNEY FORGE</b> STATION 2, 3, & 6 SPINDLE COVERS FOR MEDIUM KINGSBURY
TOLERANCES:		DRAWN	D.D.	
FRACTIONAL: ± 1/64"		CHECKED	5/10/2010	
ANGULAR: MACH ± 1° BEND ±		ENG APPR.		
TWO PLACE DECIMAL ± .010		MFG APPR.		SIZE DWG. NO. XXXXXXXXXXXXXXXX
THREE PLACE DECIMAL ± .005		Q.A.		SCALE: 1/2" = 1"
MATERIAL 12 GAUGE		COMMENTS:		WEIGHT:      SHEET 1 OF 1
FINISH				REV.
DO NOT SCALE DRAWING				

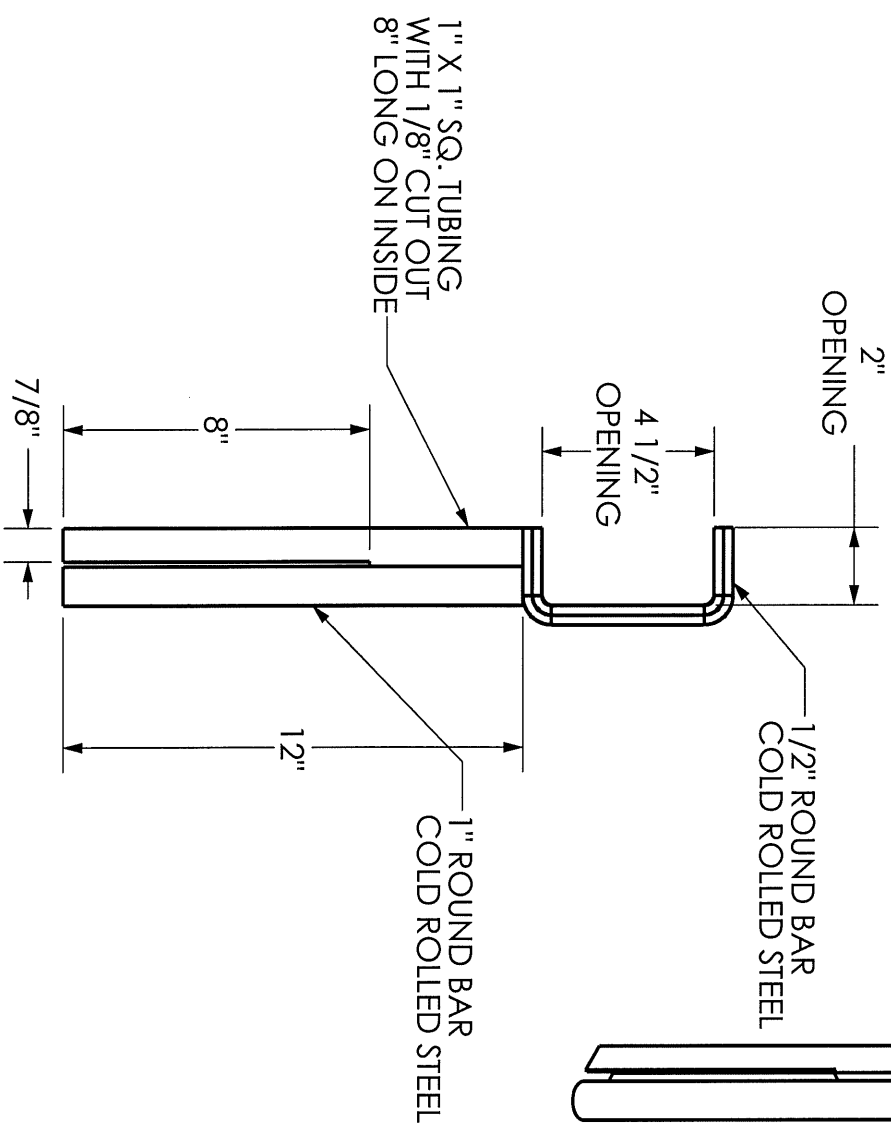
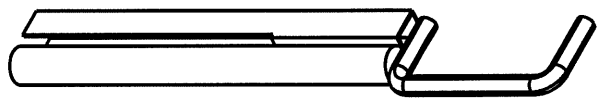

REVISIONS		
REV.	DESCRIPTION	DATE

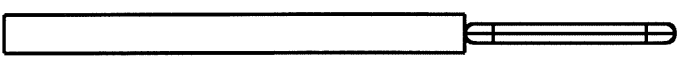

QTY. 12

**PROPRIETARY AND CONFIDENTIAL**  
 THE INFORMATION CONTAINED IN THIS DRAWING IS THE SOLE PROPERTY OF BONNEY FORGE. ANY REPRODUCTION IN PART OR AS A WHOLE WITHOUT THE WRITTEN PERMISSION OF BONNEY FORGE IS PROHIBITED.

DIMENSIONS ARE IN INCHES		NAME	DATE
TOLERANCES:		D.D.	5/10/2010
FRACTIONAL: ± 1/64"		CHECKED	
ANGULAR: MACH ± 1° BEND ±		ENG APPR.	
TWO PLACE DECIMAL ± .010		MFG APPR.	
THREE PLACE DECIMAL ± .005		Q.A.	
MATERIAL (SEE NOTES)		COMMENTS:	
FINISH			
DO NOT SCALE DRAWING			

<b>BONNEY FORGE</b>			
SIDE WELD ON PCS. WELDMENTS ON MEDIUM KINGSBURY			
SIZE	DWG. NO.	WEIGHT	REV.
A	XXXXXXXXXXXXXXXXXX		
SCALE: 1:4	SHEET 1 OF 1		

REV. NO.		DESCRIPTION	DATE	APPROVED

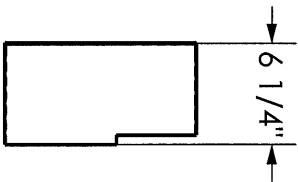
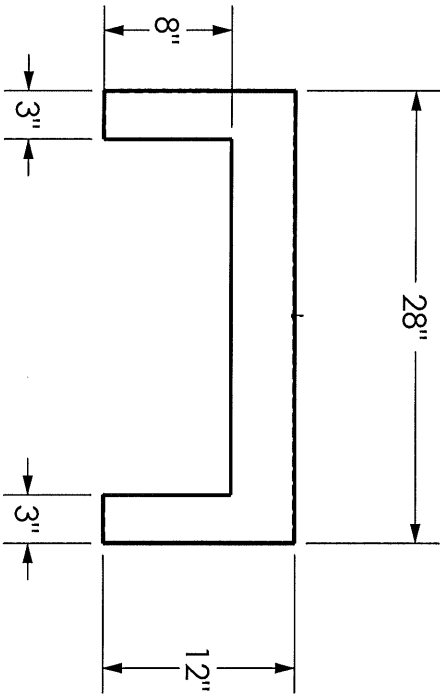
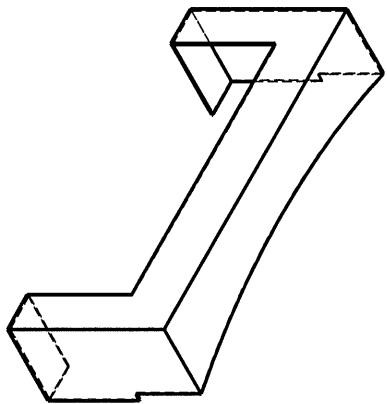
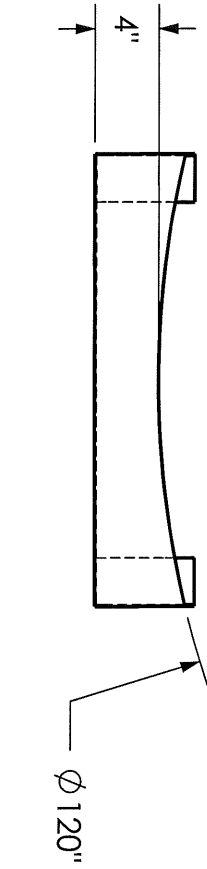

QTY: 3

**PROPRIETARY AND CONFIDENTIAL**  
 THE INFORMATION CONTAINED IN THIS DRAWING IS THE SOLE PROPERTY OF BONNEY FORGE. ANY REPRODUCTION IN PART OR AS A WHOLE WITHOUT THE WRITTEN PERMISSION OF BONNEY FORGE IS PROHIBITED.

DIMENSIONS ARE IN INCHES		DRAWN	NAME	DATE
TOLERANCES:		D.D.		5/10/2010
FRACTIONAL ± 1/64"		CHECKED		
ANGULAR: MACH ± 1° BEND ±		ENG APPR.		
TWO PLACE DECIMAL ± .010		MFG APPR.		
THREE PLACE DECIMAL ± .005		Q.A.		
MATERIAL		COMMENTS:		
12 GAUGE				
FINISH				
DO NOT SCALE DRAWING				
<b>BONNEY FORGE</b> WELDMENT FOR TOP OF MACHINE( 28" P.C.) MEDIUM KINGSBURY				
SIZE	DWG. NO.	REVISIONS		REV.
A	XXXXXXXXXXXXXXXXXX			
SCALE: 1/2	WEIGHT:	SHEET 1 OF 1		

REVISIONS		
REV.	DESCRIPTION	DATE

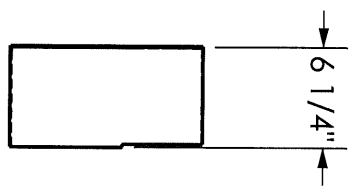
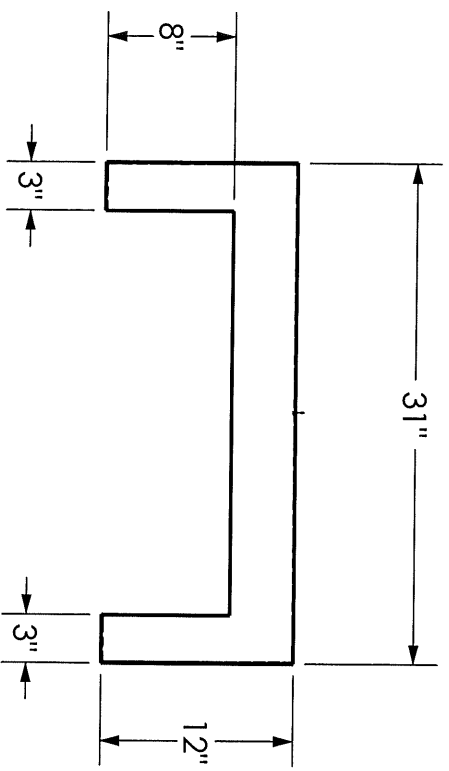
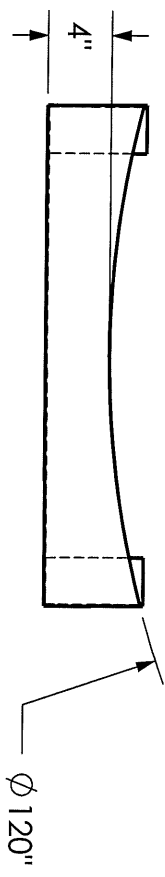
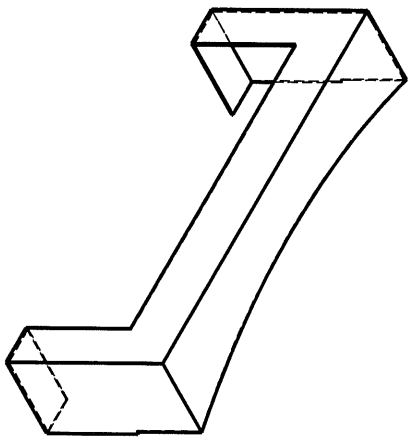

QTY: 2

**PROPRIETARY AND CONFIDENTIAL**  
 THE INFORMATION CONTAINED IN THIS DRAWING IS THE SOLE PROPERTY OF BONNEY FORGE. ANY REPRODUCTION IN PART OR AS A WHOLE WITHOUT THE WRITTEN PERMISSION OF BONNEY FORGE IS PROHIBITED.

DIMENSIONS ARE IN INCHES TOLERANCES: 1/64"		NAME		DATE	
FRACTIONAL: ± 1/64"		D.D.		5/10/2010	
ANGULAR: MACH ± 1° BEND ±		CHECKED			
TWO PLACE DECIMAL ± .010		ENG APPR.			
THREE PLACE DECIMAL ± .005		MFG APPR.			
MATERIAL		Q.A.			
12 GAUGE		COMMENTS:			
FINISH					
DO NOT SCALE DRAWING					
<b>BONNEY FORGE</b>					
WELDMENT FOR TOP OF MACHINE (31" PC.) MEDIUM KINGSBURY					
SIZE	DWG. NO.	REV.			
A	XXXXXXXXXXXXXXXXXX				
SCALE: 1:12	WEIGHT:	SHEET 1 OF 1			

REVISIONS			
REV.	DESCRIPTION	DATE	APPROVED

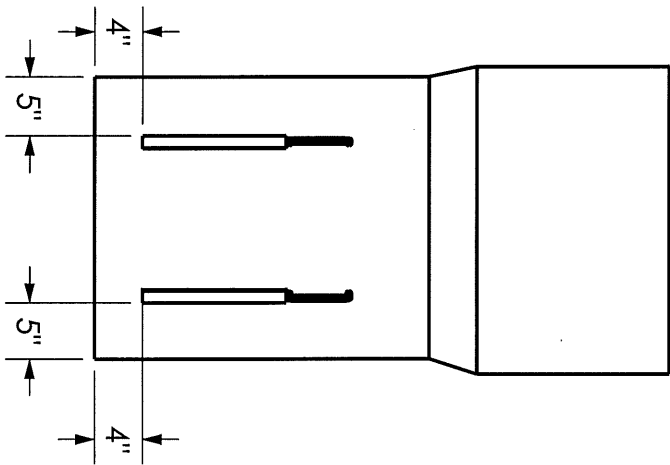
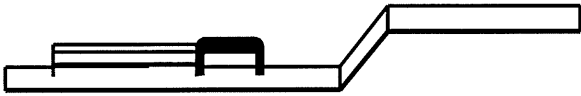
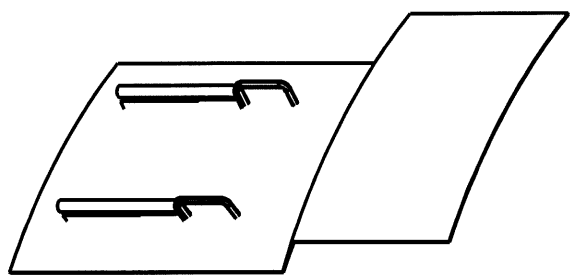

**PROPRIETARY AND CONFIDENTIAL**  
 THE INFORMATION CONTAINED IN THIS DRAWING IS THE SOLE PROPERTY OF BONNEY FORGE. ANY REPRODUCTION IN PART OR AS A WHOLE WITHOUT THE WRITTEN PERMISSION OF BONNEY FORGE IS PROHIBITED.

DIMENSIONS ARE IN INCHES	
TOLERANCES:	
FRACTIONAL: $\pm 1/64"$	
ANGULAR: MACH $\pm 1^\circ$ BEND $\pm$	
TWO PLACE DECIMAL $\pm .010$	
THREE PLACE DECIMAL $\pm .005$	
MATERIAL	XXXX
FINISH	
DO NOT SCALE DRAWING	

DRAWN	NAME	DATE
D.D.		5/10/2010
CHECKED		
ENG APPR.		
MFG APPR.		
Q.A.		
COMMENTS:		
<b>BONNEY FORGE</b> SIDES WITH HANDLE LOCATION DRAWING MEDIUM KINGSBURY		
SIZE	DWG. NO.	REV.
A	XXXXXXXXXXXXXXXXXX	
SCALE: 1:16	WEIGHT:	SHEET 1 OF 1

Ø 120"  
(TO THE INSIDE OF THE SHEET METAL)

Ø 110"  
(TO THE INSIDE OF THE SHEET METAL)

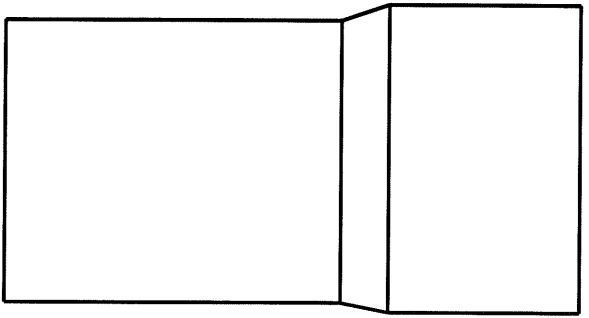
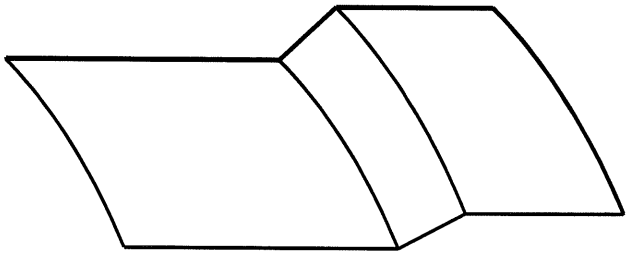
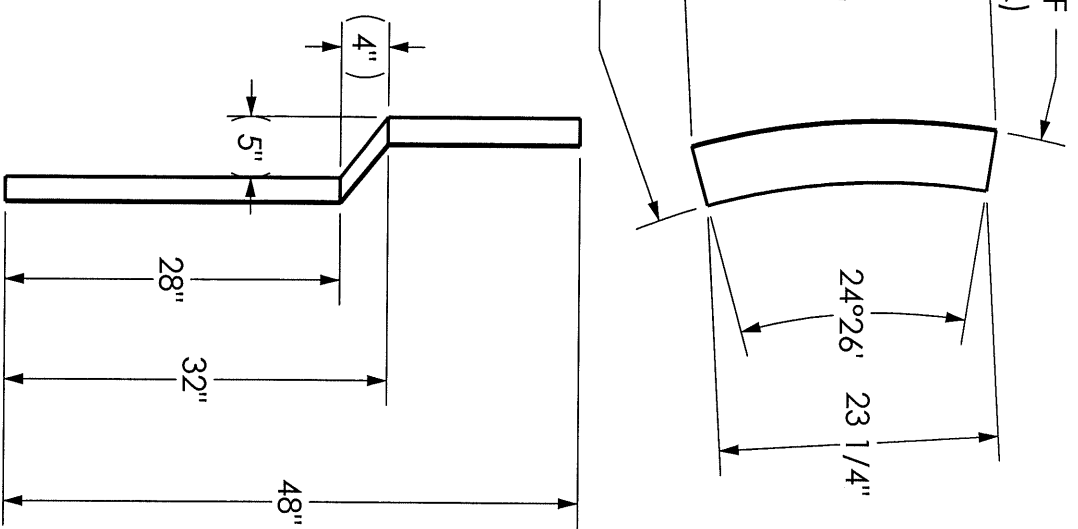

REVISIONS		DATE	APPROVED
REV.	DESCRIPTION		

QTY. 6

**PROPRIETARY AND CONFIDENTIAL**  
THE INFORMATION CONTAINED IN THIS DRAWING IS THE SOLE PROPERTY OF BONNEY FORGE. ANY REPRODUCTION IN PART OR AS A WHOLE WITHOUT THE WRITTEN PERMISSION OF BONNEY FORGE IS PROHIBITED.

DIMENSIONS ARE IN INCHES  
TOLERANCES:  
FRACTIONAL: 1/64"  
ANGULAR: MACH ± 1° BEND ±  
TWO PLACE DECIMAL ± .010  
THREE PLACE DECIMAL ± .005

MATERIAL  
**12 GAUGE**

FINISH  
DO NOT SCALE DRAWING

DRAWN	NAME	DATE
CHECKED		
ENG APPR.		
MFG APPR.		
Q.A.		

**BONNEY FORGE**  
SIDES OF GUARDING  
MEDIUM KINGSBURY

SIZE **A** DWG. NO. XXXXXXXXXXXXXXXX REV.  
SCALE: 1/4" = 1" WEIGHT: SHEET 1 OF 1

REVISIONS		DATE	APPROVED
REV.	DESCRIPTION		

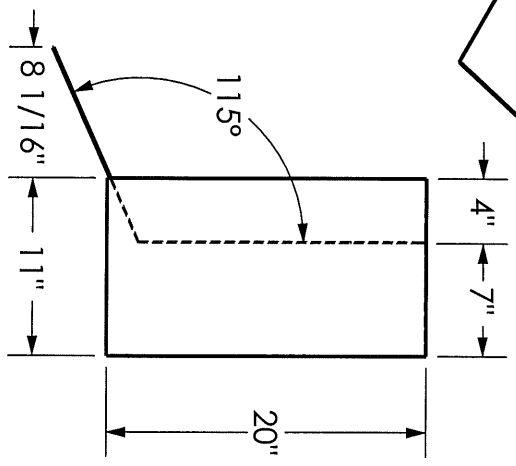
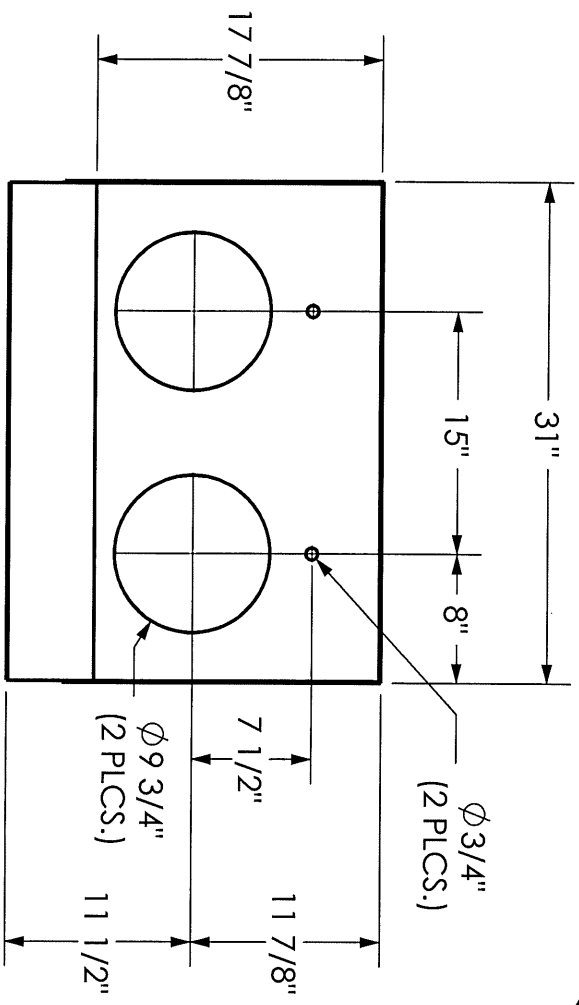
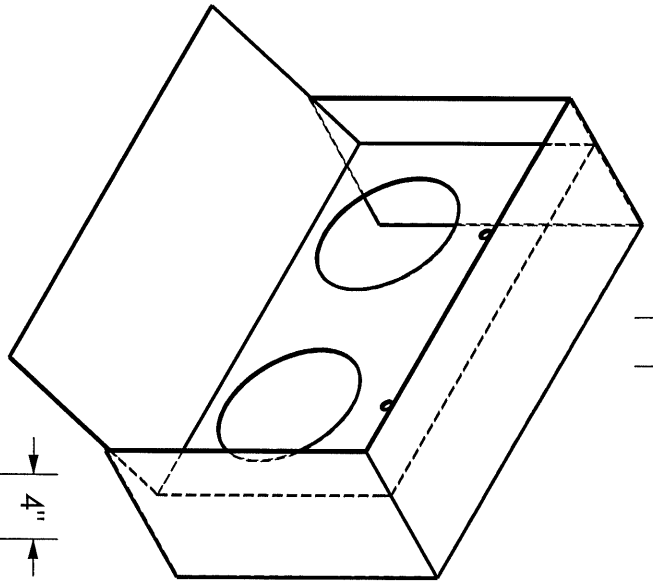
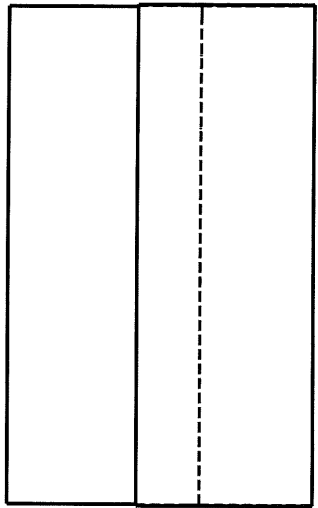

QTY: 2

**PROPRIETARY AND CONFIDENTIAL**  
 THE INFORMATION CONTAINED IN THIS DRAWING IS THE SOLE PROPERTY OF BONNEY FORGE. ANY REPRODUCTION IN PART OR AS A WHOLE WITHOUT THE WRITTEN PERMISSION OF BONNEY FORGE IS PROHIBITED.

DIMENSIONS ARE IN INCHES		NAME	DATE	<b>BONNEY FORGE</b> STATION 4 & 5 SPINDLE COVERS FOR MEDIUM KINGSBURY
TOLERANCES: FRACTIONAL ± 1/64"		DRAWN	D.D.	
ANGULAR: MACH ± 1° BEND ±		CHECKED	5/10/2010	
TWO PLACE DECIMAL ± .010		ENG APPR.		
THREE PLACE DECIMAL ± .005		MFG APPR.		
MATERIAL		COMMENTS:		
FINISH				
DO NOT SCALE DRAWING				
12 GAUGE				
SIZE DWG. NO. XXXXXXXXXXXXXXXX		SCALE: 1:12		WEIGHT: SHEET 1 OF 1
REV.				

REVISIONS		DATE	APPROVED
REV.	DESCRIPTION		

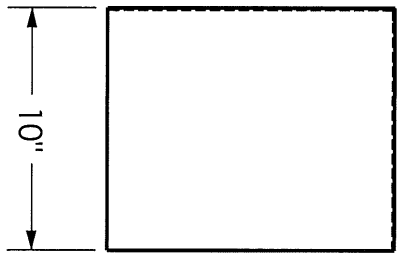
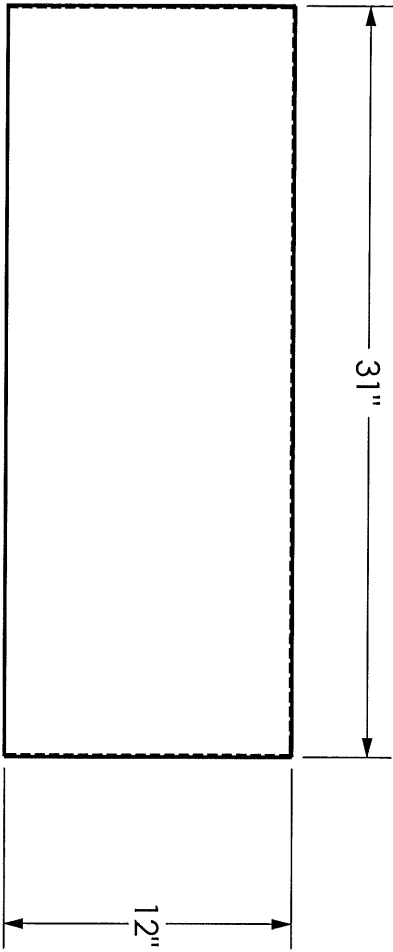
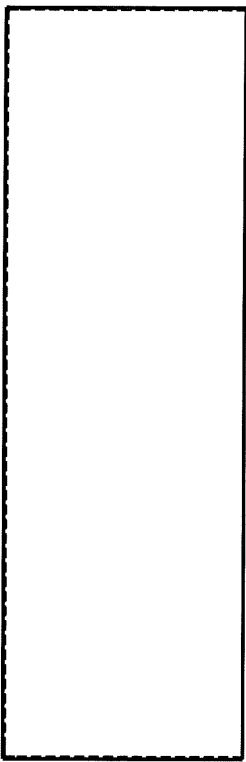
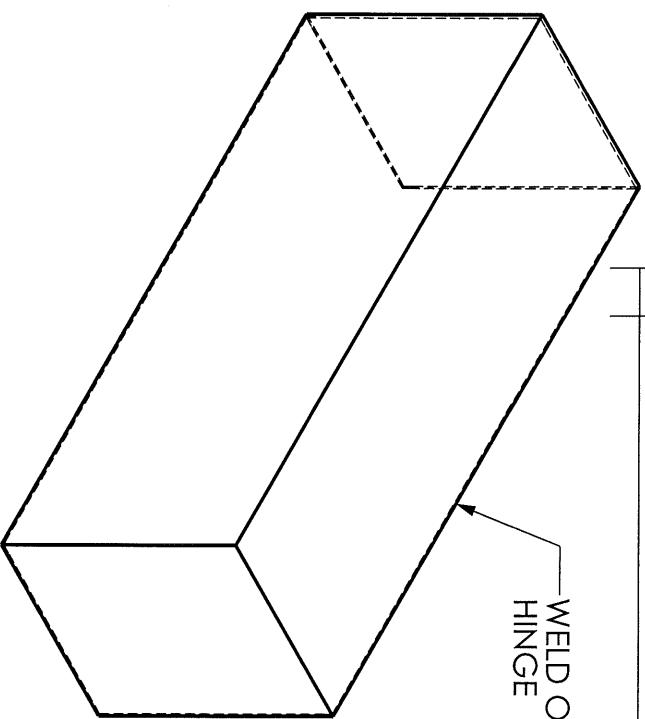

QTY: 2

**PROPRIETARY AND CONFIDENTIAL**  
 THE INFORMATION CONTAINED IN THIS DRAWING IS THE SOLE PROPERTY OF BONNEY FORGE. ANY REPRODUCTION IN PART OR AS A WHOLE WITHOUT THE WRITTEN PERMISSION OF BONNEY FORGE IS PROHIBITED.

DIMENSIONS ARE IN INCHES		NAME	DATE	<b>BONNEY FORGE</b>
TOLERANCES:		D.D.	5/10/2010	
FRACTIONAL: ± 1/64"		DRAWN		TOOL CHANGE LID (31" P.C.) MEDIUM KINGSBURY
ANGULAR: MACH ± 1° BEND ±		CHECKED		
TWO PLACE DECIMAL ± .010		ENG APPR.		
THREE PLACE DECIMAL ± .005		MFG APPR.		
MATERIAL	12 GAUGE	Q.A.		SIZE <b>A</b>
FINISH		COMMENTS:		DWG. NO. XXXXXXXXXXXXXXXX
DO NOT SCALE DRAWING				SCALE: 1:8
				WEIGHT:
				SHEET 1 OF 1



REV.	DESCRIPTION	DATE	APPROVED

WELD A HINGE ON

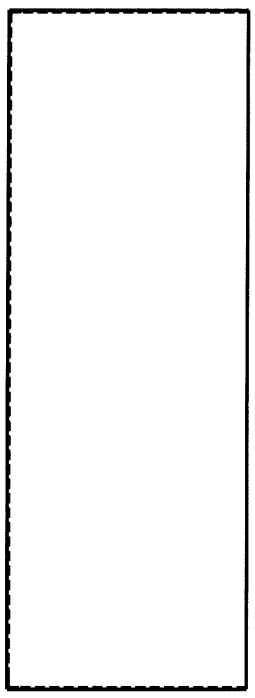
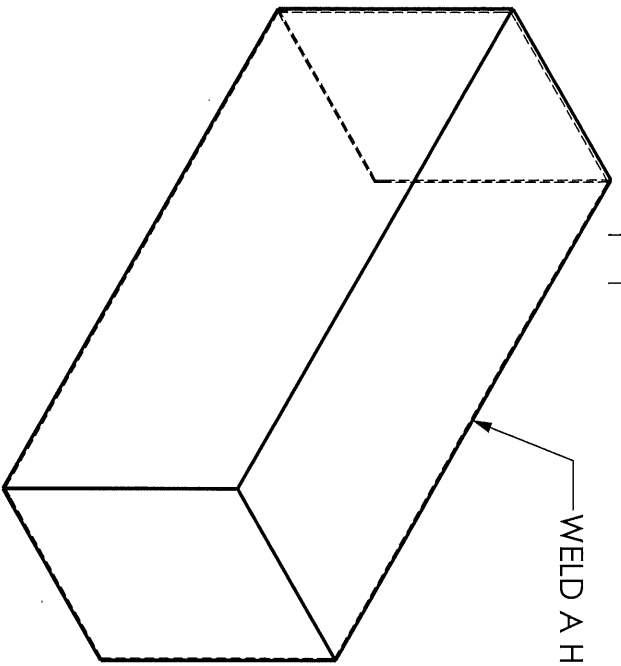

28"

12"

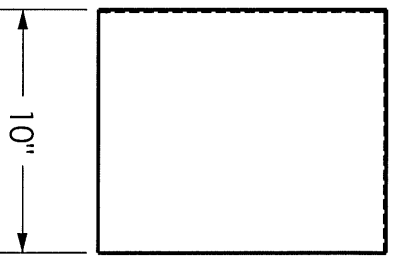
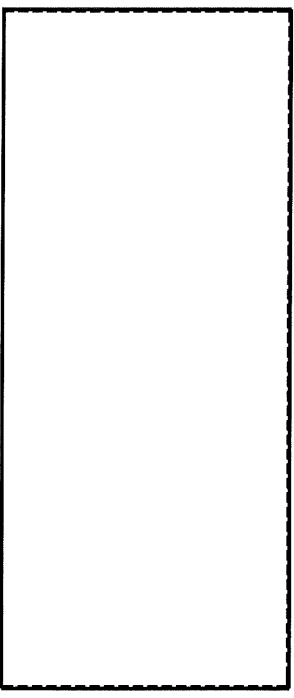

10"

QTY: 3

**PROPRIETARY AND CONFIDENTIAL**  
 THE INFORMATION CONTAINED IN THIS DRAWING IS THE SOLE PROPERTY OF BONNEY FORGE. ANY REPRODUCTION IN PART OR AS A WHOLE WITHOUT THE WRITTEN PERMISSION OF BONNEY FORGE IS PROHIBITED.

DIMENSIONS ARE IN INCHES TOLERANCES: FRACTIONAL: ± 1/64" ANGULAR: MACH ± 1° BEND ± TWO PLACE DECIMAL ± .010 THREE PLACE DECIMAL ± .005		NAME	DATE
MATERIAL <b>12 GAUGE</b>		DRAWN	D.D.
FINISH DO NOT SCALE DRAWING		CHECKED	5/10/2010
COMMENTS:		ENG APPR.	
		MFG APPR.	
		Q.A.	
<b>BONNEY FORGE</b> TOOL CHANGE LID (28" P.C.) MEDIUM KINGSBURY		SCALE: 1/8"	REV. 1 OF 1

REVISIONS		DATE	APPROVED
REV.	DESCRIPTION		

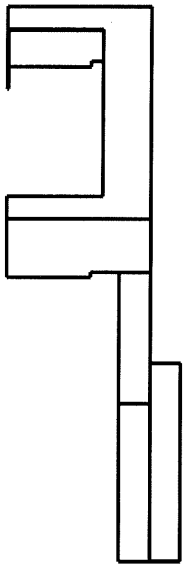
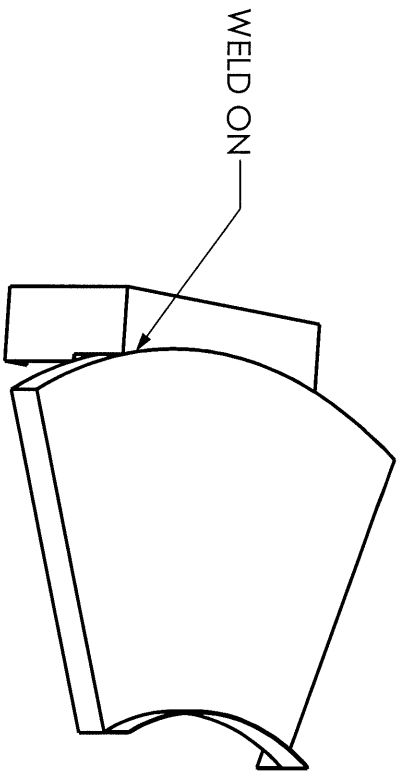
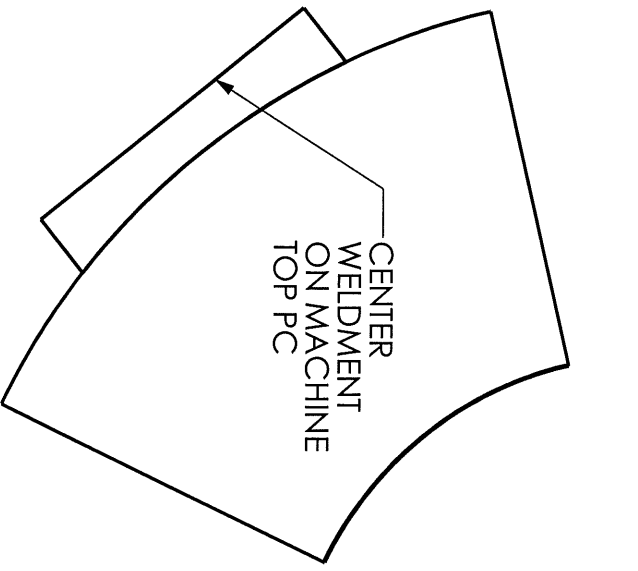

**PROPRIETARY AND CONFIDENTIAL**  
 THE INFORMATION CONTAINED IN THIS DRAWING IS THE SOLE PROPERTY OF BONNEY FORGE. ANY REPRODUCTION IN PART OR AS A WHOLE WITHOUT THE WRITTEN PERMISSION OF BONNEY FORGE IS PROHIBITED.

DIMENSIONS ARE IN INCHES		DRAWN	NAME	DATE
TOLERANCES:			D.D.	5/10/2010
FRACTIONAL: ± 1/64"		CHECKED		
ANGULAR: MACH ± 1° BEND ±		ENG APPR.		
TWO PLACE DECIMAL ± .010		MFG APPR.		
THREE PLACE DECIMAL ± .005		Q.A.		
MATERIAL		COMMENTS:		
XXXX				
FINISH				
DO NOT SCALE DRAWING				
<b>BONNEY FORGE</b>				
<b>TOP OF MACHINE PC AND WELDMENT DRAWING</b>				
SIZE	DWG. NO.	XXXXXXXXXXXXXXXXXX		REV.
A				
SCALE: 1:16	WEIGHT:			SHEET 1 OF 1

REV.	DESCRIPTION	DATE	APPROVED

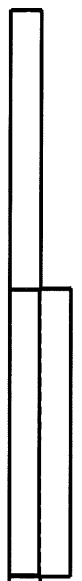
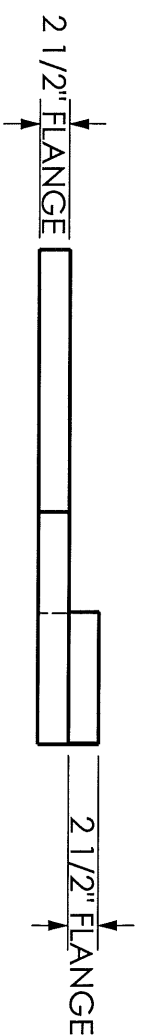
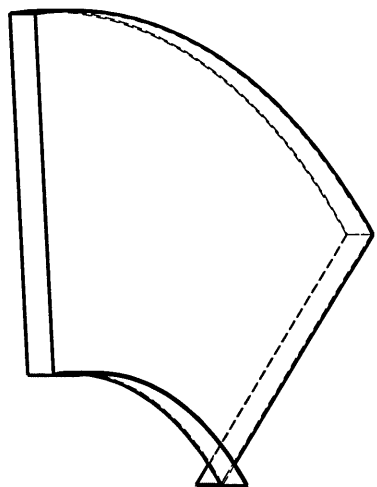
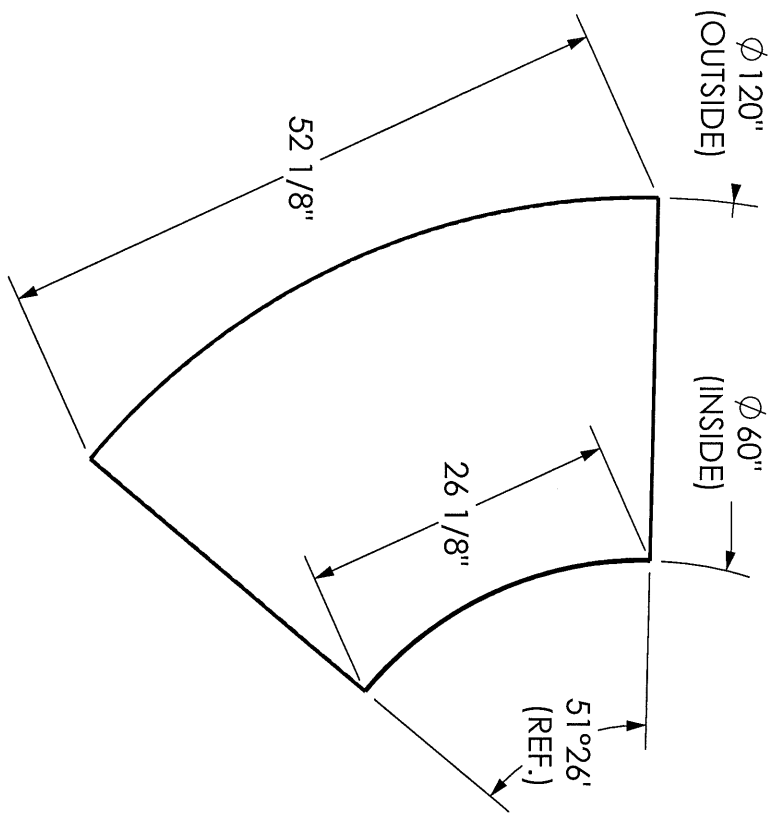

QTY: 5

**PROPRIETARY AND CONFIDENTIAL**  
 THE INFORMATION CONTAINED IN THIS DRAWING IS THE SOLE PROPERTY OF BONNEY FORGE. ANY REPRODUCTION IN PART OR AS A WHOLE WITHOUT THE WRITTEN PERMISSION OF BONNEY FORGE IS PROHIBITED.

DIMENSIONS ARE IN INCHES		DRAWN	NAME	DATE
TOLERANCES:		D.D.		5/10/2010
FRACTIONAL $\pm 1/64''$		CHECKED		
ANGULAR: MACH $\pm 1^\circ$ BEND $\pm$		ENG APPR.		
TWO PLACE DECIMAL $\pm .010$		MFG APPR.		
THREE PLACE DECIMAL $\pm .005$		Q.A.		
COMMENTS:				
MATERIAL				
12 GAUGE				
FINISH				
DO NOT SCALE DRAWING				
<b>BONNEY FORGE</b> TOP OF MACHINE PCS. MEDIUM KINGSBURY				
SIZE	DWG. NO.	XXXXXXXXXXXXXXXXXX		REV.
A				
SCALE: 1:16	WEIGHT:			SHEET 1 OF 1

REV.	REVISIONS	DESCRIPTION	DATE	APPROVED

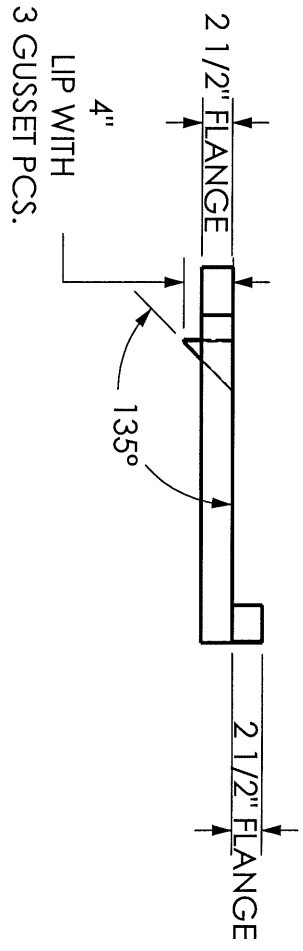
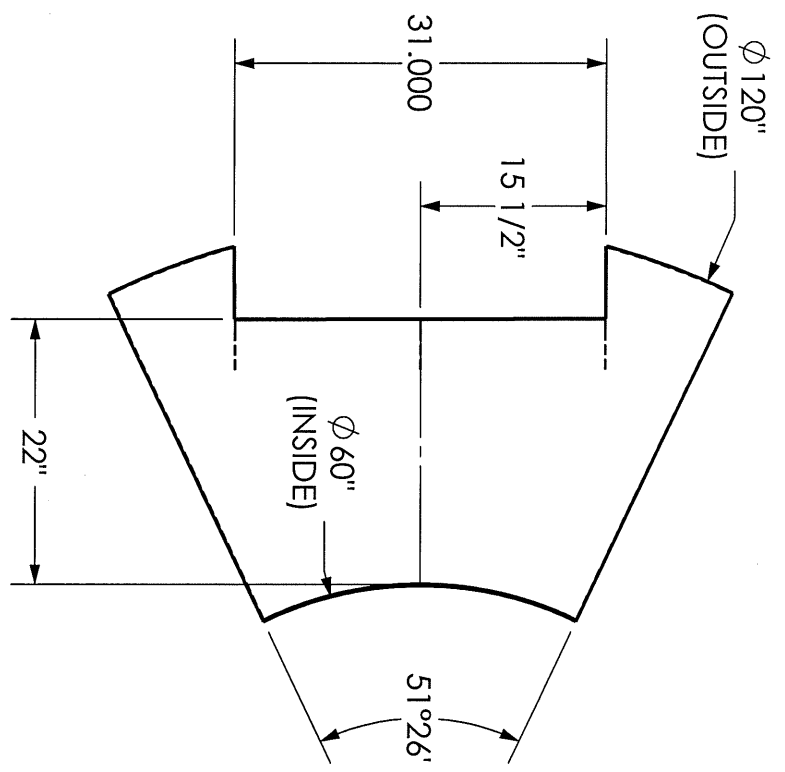

3 GUSSET PCS.

QTY. 5

PROPRIETARY AND CONFIDENTIAL  
 THE INFORMATION CONTAINED IN THIS  
 DRAWING IS THE SOLE PROPERTY OF  
 BONNEY FORGE. ANY REPRODUCTION IN  
 PART OR AS A WHOLE WITHOUT THE  
 WRITTEN PERMISSION OF BONNEY FORGE  
 IS PROHIBITED.

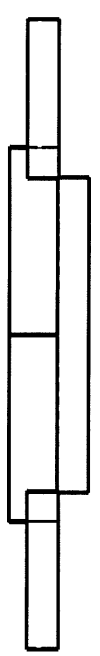
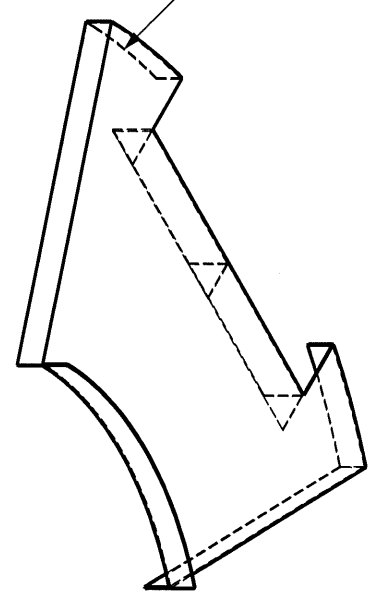

DIMENSIONS ARE IN INCHES		DRAWN	NAME	DATE	<b>BONNEY FORGE</b> TOP OF SPINDLE PCS ON MEDIUM KINGSBURY
TOLERANCES:			D.D.	5/10/2010	
FRACTIONAL: $\pm 1/64"$		CHECKED			
ANGULAR: MACH $\pm 1^\circ$ BEND $\pm$		ENG APPR			
TWO PLACE DECIMAL $\pm .010$		MFG APPR			
THREE PLACE DECIMAL $\pm .005$		Q.A.			
MATERIAL		COMMENTS:			SIZE
12 GAUGE					DWG. NO.
FINISH					XXXXXXXXXXXXXXXXXXXX
DO NOT SCALE DRAWING					SCALE: 1:16
					WEIGHT:
					SHEET OF 1

REVISIONS			
REV.	DESCRIPTION	DATE	APPROVED

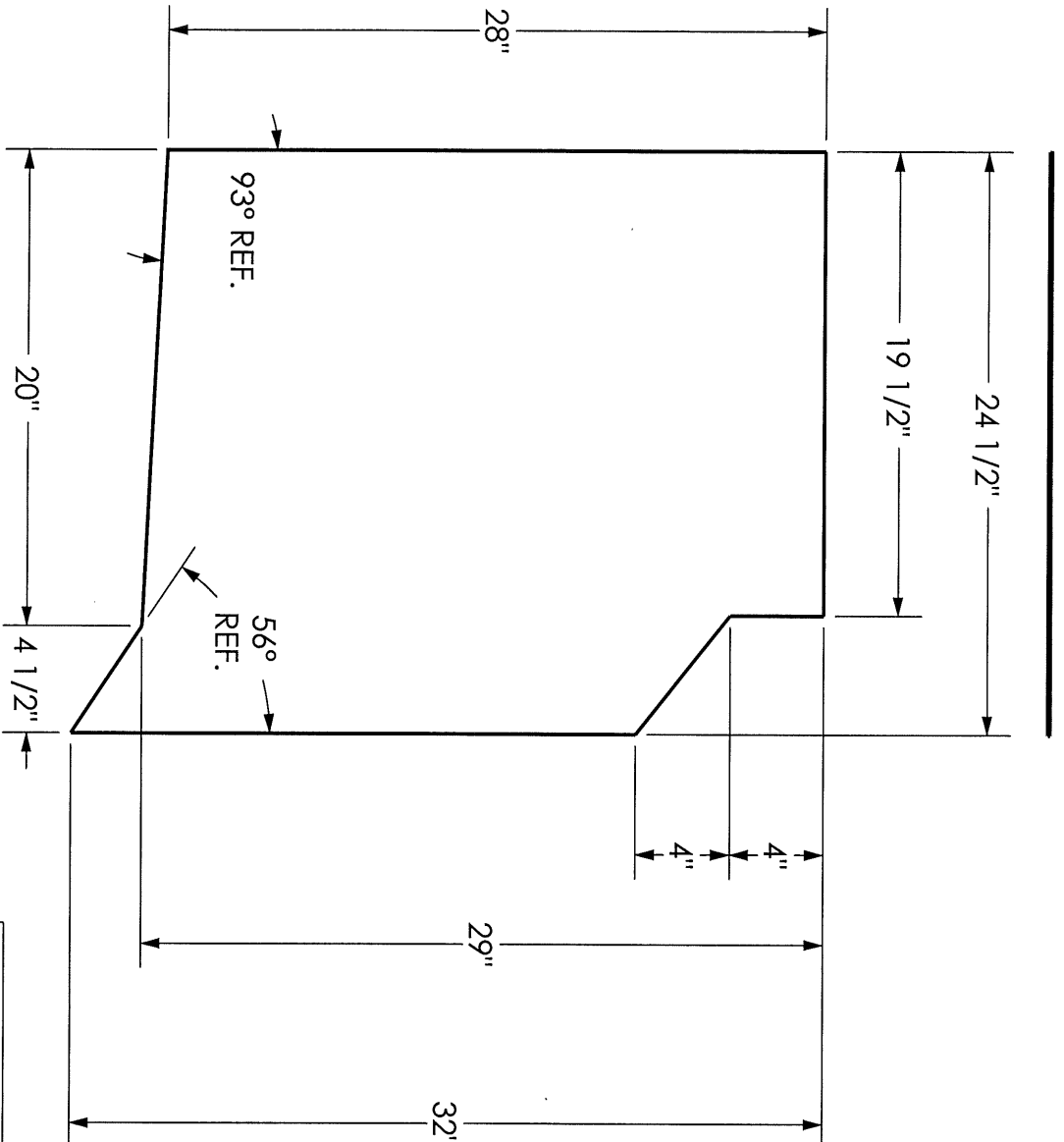

QTY: 10

**PROPRIETARY AND CONFIDENTIAL**  
 THE INFORMATION CONTAINED IN THIS DRAWING IS THE SOLE PROPERTY OF BONNEY FORGE. ANY REPRODUCTION IN PART OR AS A WHOLE WITHOUT THE WRITTEN PERMISSION OF BONNEY FORGE IS PROHIBITED.

DIMENSIONS ARE IN INCHES		DRAWN		NAME		DATE	
TOLERANCES:		D.D.		D.D.		5/10/2010	
FRACTIONAL: 1/64"		CHECKED					
ANGULAR: MACH ± 1° BEND ±		ENG APPR					
TWO PLACE DECIMAL ± .010		MFG APPR					
THREE PLACE DECIMAL ± .005		Q.A.					
MATERIAL		COMMENTS:					
12 GAUGE							
FINISH							
DO NOT SCALE DRAWING							
<b>BONNEY FORGE</b> SPINDLE SIDE COVERS MEDIUM KINGSBURY				SITE DWG. NO. XXXXXXXXXXXXXXXX SCALE: 1:8 WEIGHT: SHEET 1 OF 1			

