

DO NOT SCALE

IF IN DOUBT ASK



Revisions

Rev	Description	Date	Approved
-----	-------------	------	----------

Hanging Arm 8"*5' with 55 gallon drum

Diameter: 8"

Length: 5'

Weight: 50 lbs (net)

Arm Construction: Two galvanized steel tubes, three pieces of flex hose at joints, aluminum hood, heavy gauge steel swivel base, and support spring.

Arm Adjustment: Externally supported, adjustments are quickly done at the joints.

Hood: 1/2 shaped moon hood

Damper: Internal with external adjustment.

Finish: Powder coated.

Hose: Rated at 200

Accessories: Mounting bracket and light kit.

55 Gallon Drum: not shown

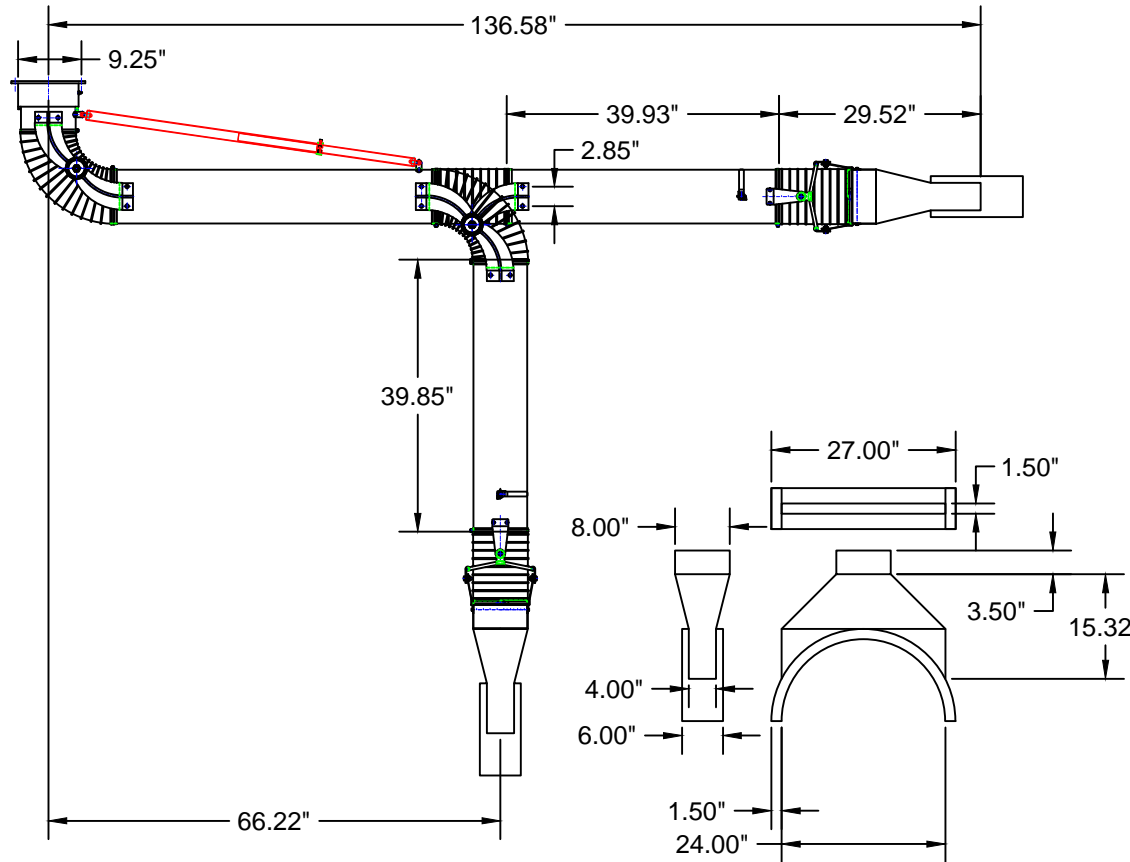

Avani Environmental Intl
95 Cypress Drive
Youngsville, NC 27596

Sales Department
(919) 570-2862

Date	Name	Part Number:	Title:
2/10/13	MDT	PART NO.	Arm 2020 with 20" Hood
This drawing is confidential and is the exclusive property of San Mao Technology. No unauthorized use/copy or disclosure is to be made and it is returned whenever required.			Size A
			Scale 1 = xx
			Drawing Number: 2011.11.22