

SEE SHEET #1 FOR CHART OF VENDOR PROVIDED PARTS

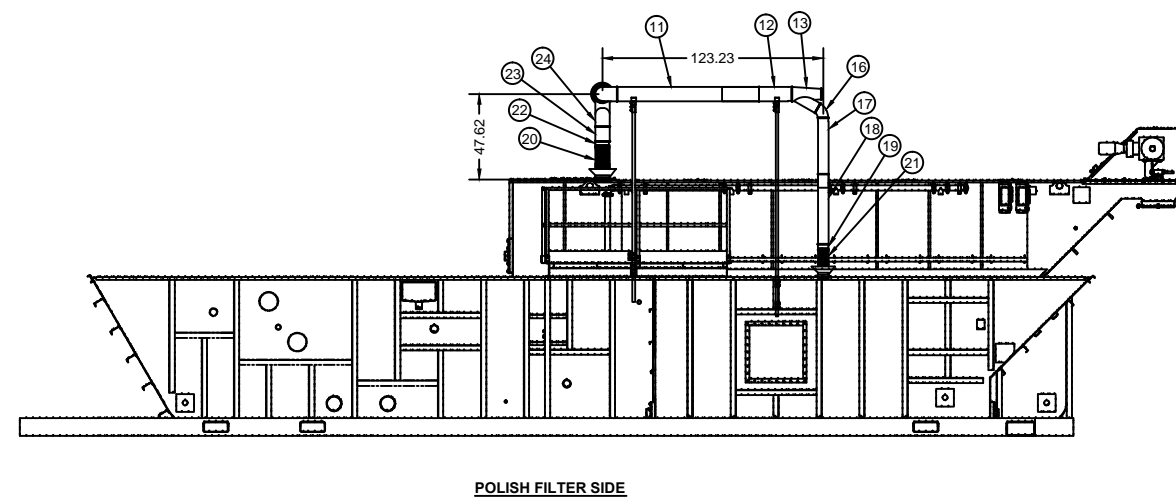
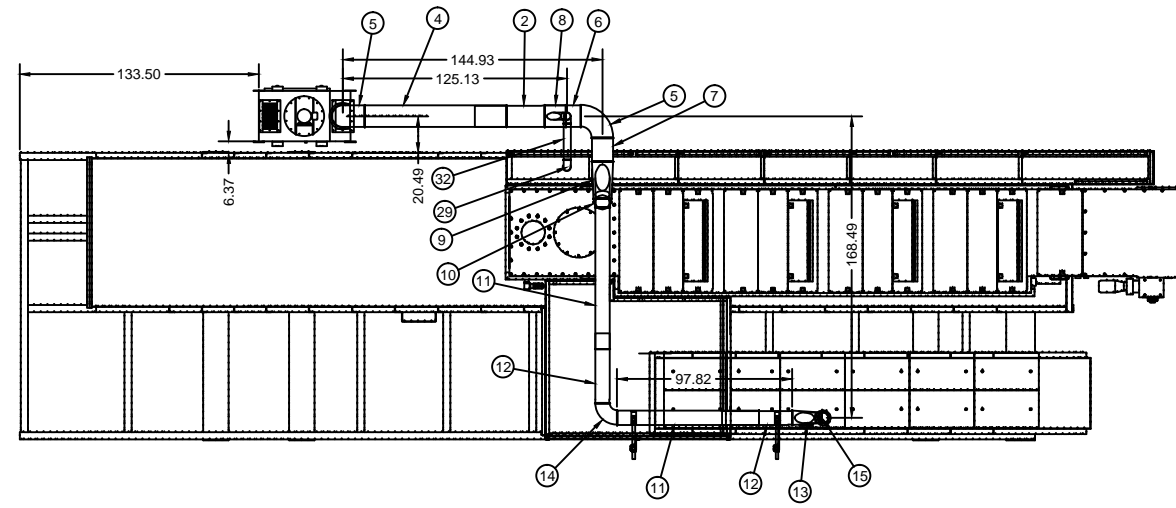
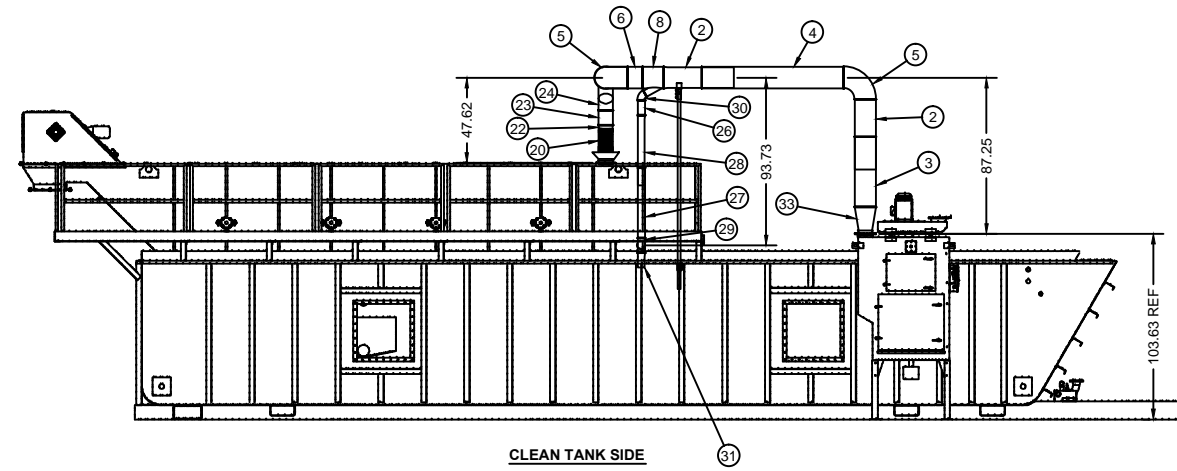

LEGEND
 ○ SEE DRAWING BILL OF MATERIAL
 ◐ SEE REFERENCE BILL OF MATERIAL
 ▲ REVISIONS

| | | | |
|-----------------------------|----------------|---|--------------|
| SCALE: 1" = 32" | | TITLE: G2000 MIST COLLECTION DUCT PARTS | |
| DESIGN: BML | DATE: 10/24/14 | ORDER NO.: 79.80095.1005 | SHEET 2 OF 2 |
| DRAWN: BML | CHECKED: MB | REVISED: - | REV: - |
| DATE: 10/24/14 | CHECKED: MB | REVISED: - | REV: - |
| REF. DRAWING: 79.80095.0047 | | | |