

Product Specifications

LENGTH 51-1/4 INCHES
 WIDTH 25 INCHES
 HEIGHT 28 INCHES
 CAPACITY .50 CUBIC YARDS
 CAPACITY 6000 LBS
 COLOR FINISH Blue
 CONSTRUCTION Steel
 FORK POCKET CENTER 11-3/4 INCHES
 MANUFACTURERS PART NUMBERH-50-HD
 WALL GAUGE 8
 WEIGHT 269 LBS

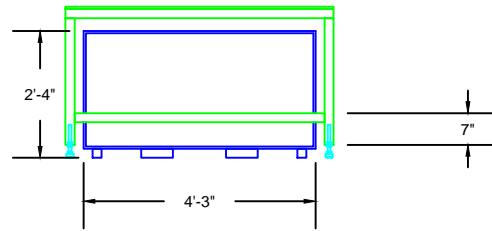

Rear View

This rugged material handling equipment attaches to your forklift. Low profile design puts hopper within easy reach. Single operator can easily dump hopper contents by pulling the 4'L steel cable while seated on the forklift; the balanced hopper tilts to an industry-optimal 90°. Rubber bumper cushions and stops tilt, and hopper automatically returns to the upright, locked position when lowered to the ground. Reinforced and braced formed galvanized steel base and precision robotic welds provide a strong, industrial grade unit (leakproof hoppers are available upon request). Durable powder coat finish. Heavy duty safety chain secures hopper to forklift. Fork pockets measure 22"L x 7"W x 2"H.

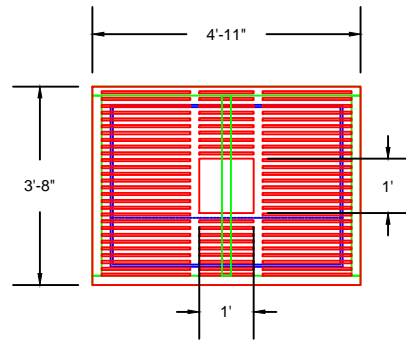
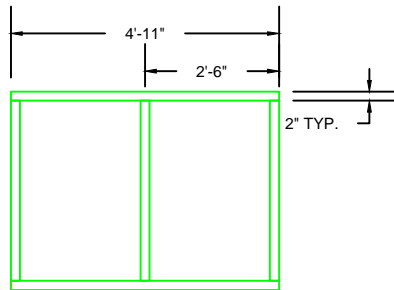

Plan View

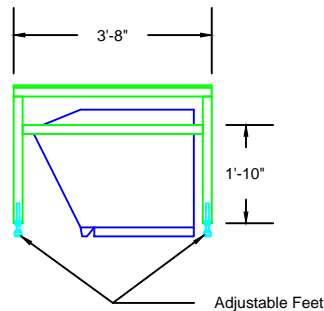
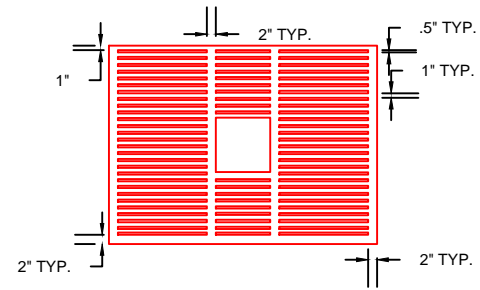

Adjustable Feet

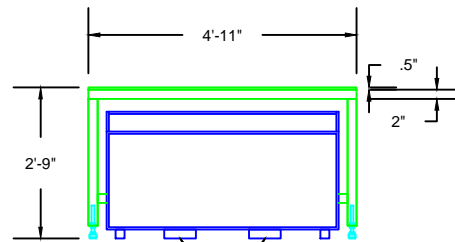

Front View

Forklift Pockets
22"L x 7"W x 2"H

PRELIMINARY

This product has not been tested for seismic calculations.

Any Customer requested, or caused changes or deviations from the approved drawing that effect T&M will require a change order.

Avani Environmental Intl. Inc.
 95 Cypress Drive
 Youngsville, NC 27596
 P# 919-570-2862 F# 919-570-2863

Avani

Project: American Casting

Drawing: Slag Box

Date: 8/26/15

Drawn by: DJT

Sheet No:

Rev A