

+ Installations for WB-606612 + SDC-10-6



✚ Installations for WB-606612 + SDC-10-6



Step 1.



✚ Installations for WB-606612 + SDC-10-6



- Take out the number: **LBBU . LBBL**
- Join **LBBU** to **LBBL** with:

Hardware K				
Part name	Description	Photos	Q'ty	Grainger Model #
Hex Screw	5/16" X 3/4"		20	1YU33
Flat Washer	5/16" x OD23 x 2T		20	*1JY31

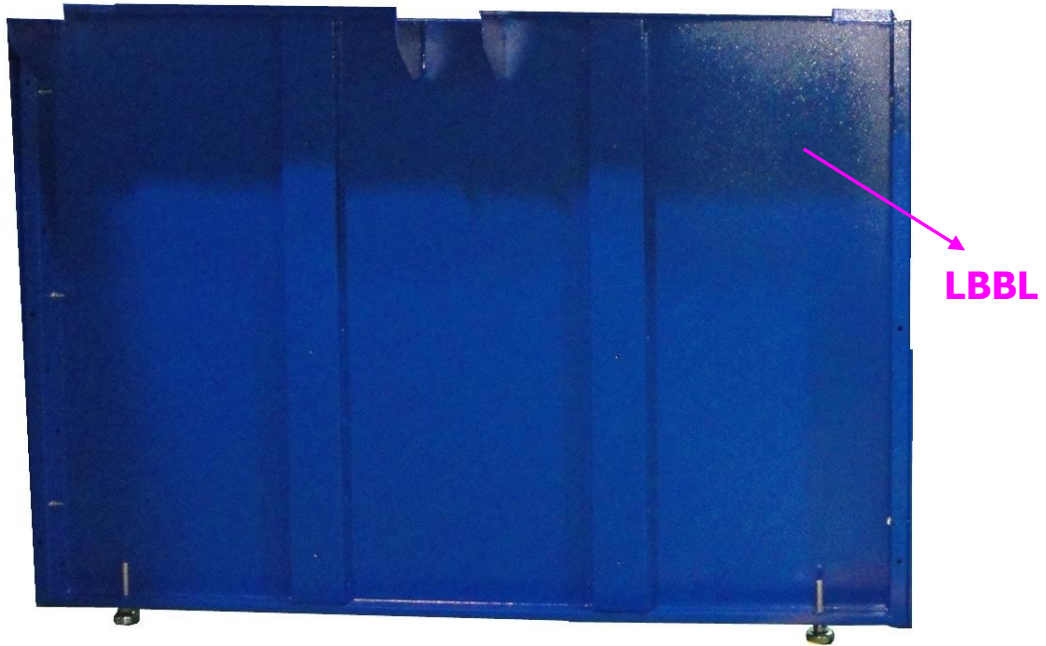
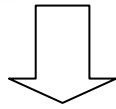

(*) Hardware item at similar spec available locally.

Installations for WB-606612 + SDC-10-6



✚ Installations for WB-606612 + SDC-10-6

- Take out the number: **LSD**
- Join **LBBU** . **LBBL** and **LSD** together with:

Hardware D				
Part name	Description	Photos	Q'ty	Grainger Model #
Half-thread Screw	3/8 x 4"		6	1KA62
Flat Washer	3/8" x OD23 x 2T		12	*1JY33
Nylon Hex Nut	3/8"		6	3HDU4

(*) Hardware item at similar spec available locally.

Installations for WB-606612 + SDC-10-6

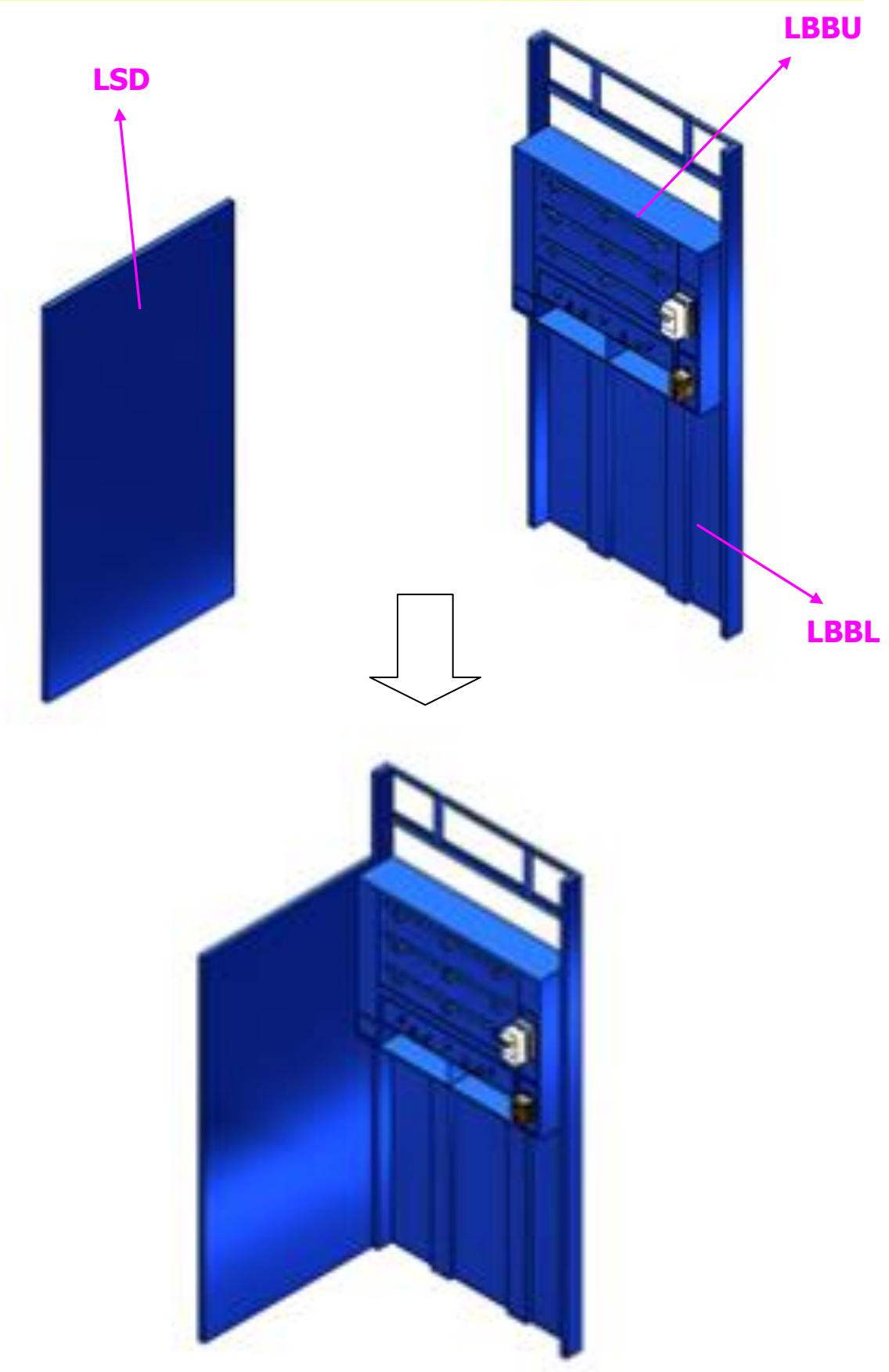

✚ Installations for WB-606612 + SDC-10-6

- Take out the number: **MSDL** and **RBBL**.
- Fasten **MSDL** to **RBBL** and **LBBL** together with:

Hardware P				
Part name	Description	Photos	Q'ty	Grainger Model #
Half-thread Screw	3/8 x 5-1/2"		8	1KA68
Flat Washer	3/8" x OD23 x 2T		16	*1JY33
Nylon Hex Nut	3/8"		8	3HDU4

(* Hardware item at similar spec available locally.

Installations for WB-606612 + SDC-10-6

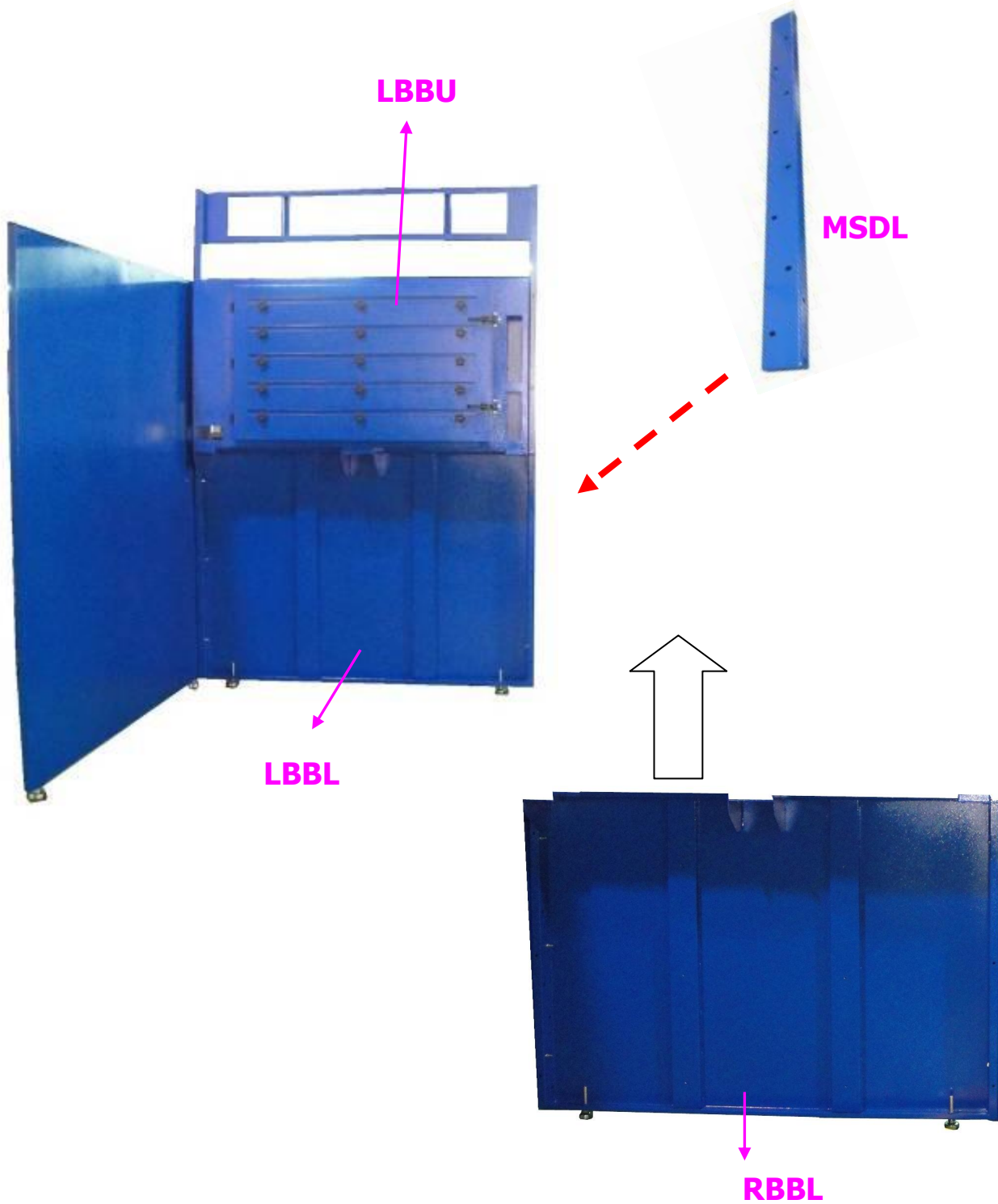

✚ Installations for WB-606612 + SDC-10-6



✚ Installations for WB-606612 + SDC-10-6



- Take out the number: **RSD**
- Join **RSD** to **RBBL** and together with:

Hardware C				
Part name	Description	Photos	Q'ty	Grainger Model #
Half-thread Screw	3/8 x 4"		6	1KA62
Flat Washer	3/8" x OD23 x 2T		12	*1JY33
Nylon Hex Nut	3/8"		6	3HDU4



(*) Hardware item at similar spec available locally.

Installations for WB-606612 + SDC-10-6



✚ Installations for WB-606612 + SDC-10-6



- Take out the number: **MSDU**
- Join **MSDU** to **LBBU** and **RBBL** together with:

Hardware P				
Part name	Description	Photos	Q'ty	Grainger Model #
Half-thread Screw	3/8 x 5-1/2"		6	1KA68
Flat Washer	3/8" x OD23 x 2T		12	*1JY33
Nylon Hex Nut	3/8"		6	3HDU4

(*) Hardware item at similar spec available locally.

✚ Installations for WB-606612 + SDC-10-6

- Join **RBBU** to **RBBL** and **RSD** together with:

Hardware K				
Part name	Description	Photos	Q'ty	Grainger Model #
Hex Screw	5/16" X 3/4"		20	1YU33
Flat Washer	5/16" x OD23 x 2T		20	*1JY31

(*) Hardware item at similar spec available locally.

Installations for WB-606612 + SDC-10-6

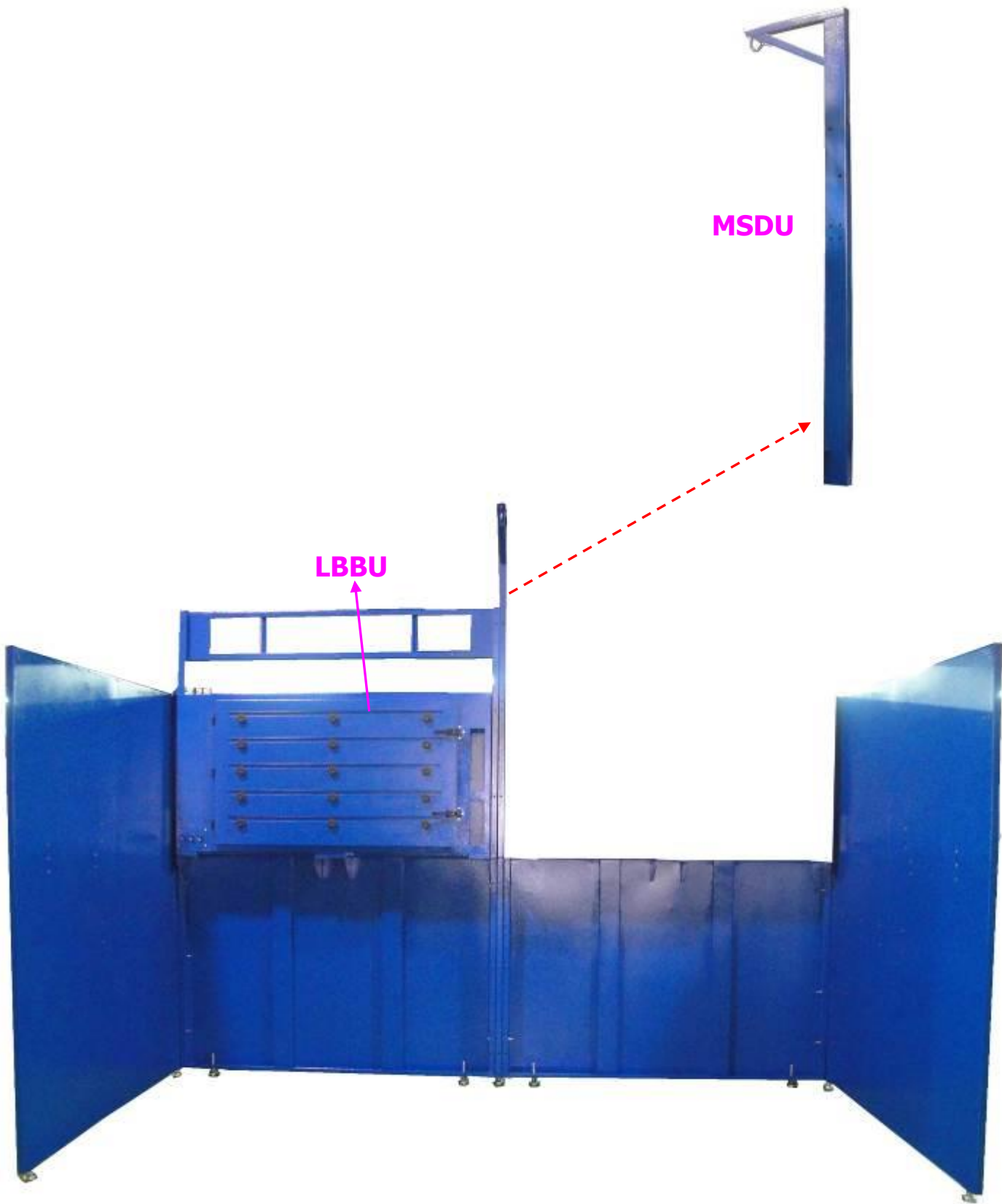

Installations for WB-606612 + SDC-10-6

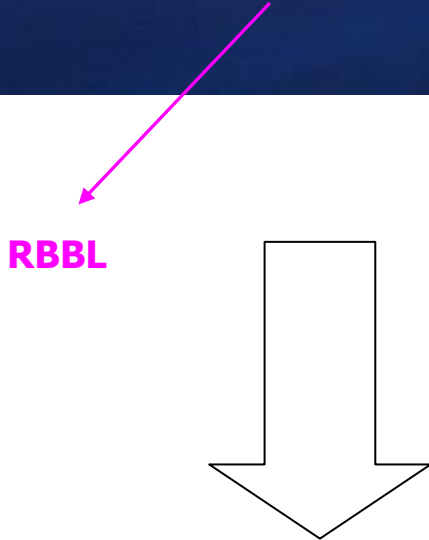
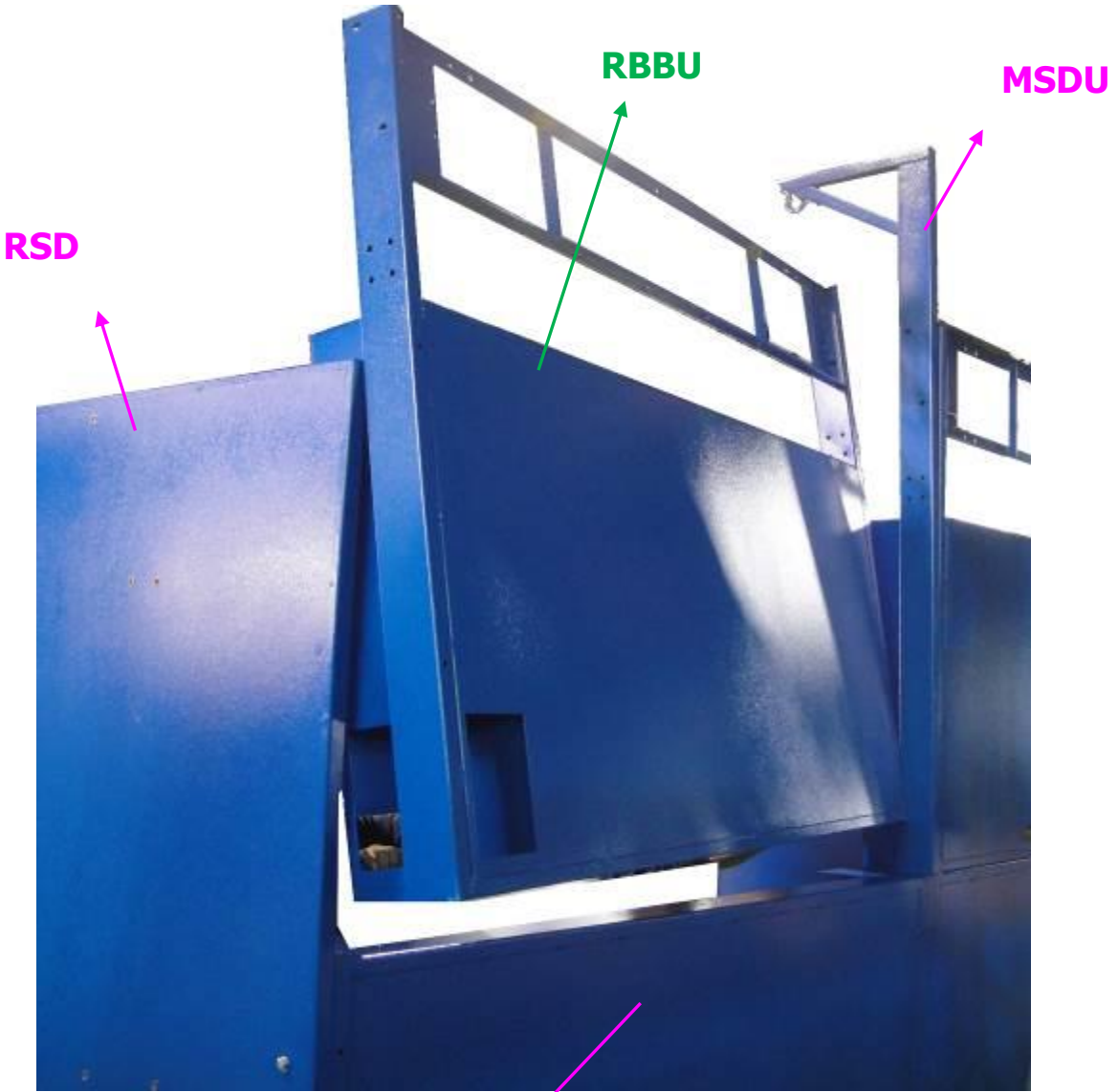

✚ Installations for WB-606612 + SDC-10-6







✚ Installations for WB-606612 + SDC-10-6

- Take out the number: **FBL**
- Fasten **FBL** to **LBBU** and **LSD** with:

Hardware A				
Part name	Description	Photos	Q'ty	Grainger Model #
Hex Screw	3/8 x 2-1/2"		2	1YU47
Nylon Hex Nut	3/8"		2	3HDU4
Flat Washer	3/8" x OD23 x 2T		4	*1JY33

(* Hardware item at similar spec available locally.

Hardware E

Part name	Description	Photos	Q'ty	Grainger Model #
Hex Screw	3/8 x 3/4"		1	1YU42
Hex Screw	5/16" X 3/4"		1	1YU33
Flat Washer	3/8" x OD23 x 2T		1	*1JY33
Flat Washer	5/16" x OD23 x 2T		1	*1JY31

✚ Installations for WB-606612 + SDC-10-6

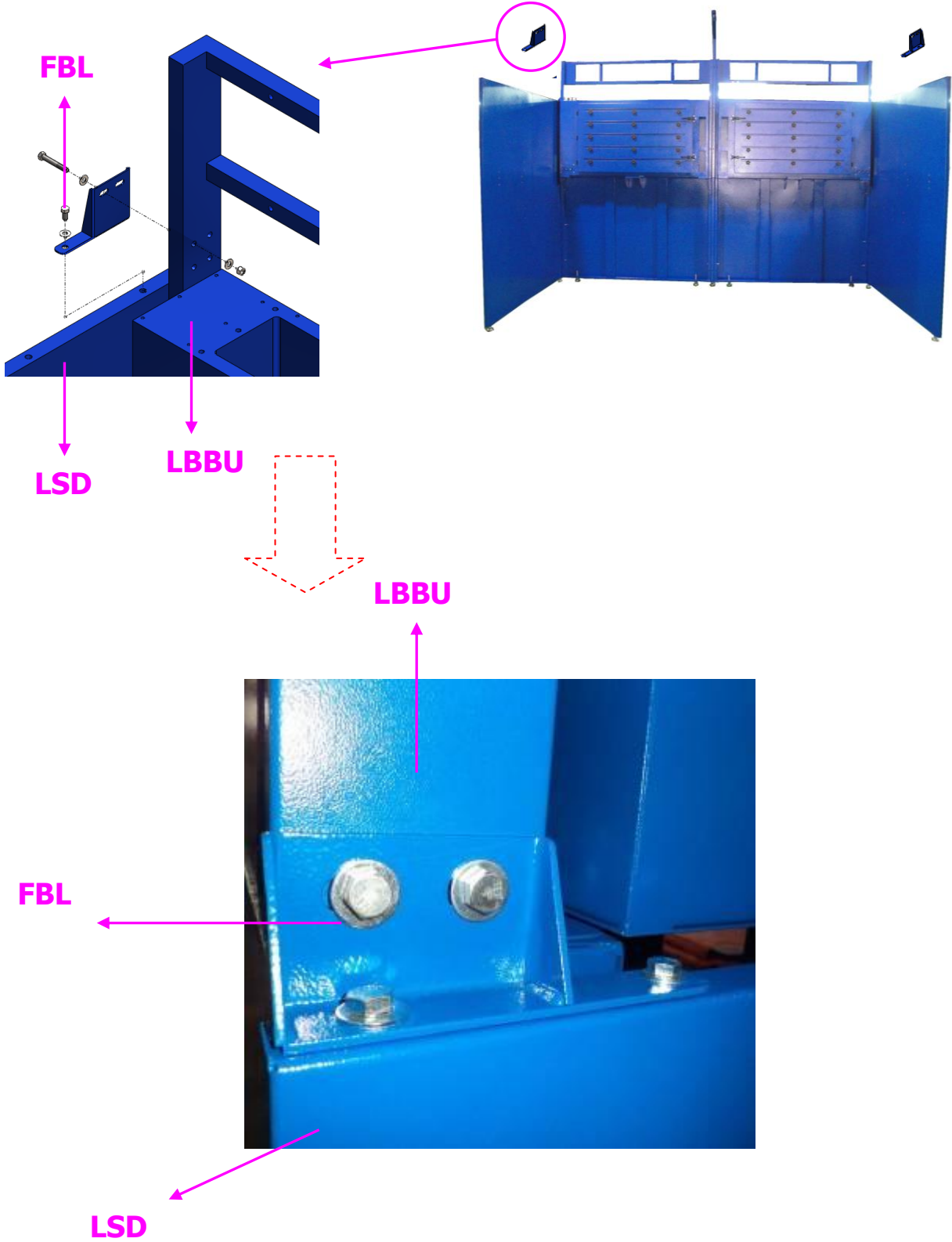

✚ Installations for WB-606612 + SDC-10-6





- Take out the number: **FBR**
- Fasten **FBR** to **RBBU** and **RSD** with:

● Hardware B

Part name	Description	Photos	Q'ty	Grainger Model #
Hex Screw	3/8 x 2-1/2"		2	1YU47
Nylon Hex Nut	3/8"		2	3HDU4
Flat Washer	3/8" x OD23 x 2T		4	*1JY33

(* Hardware item at similar spec available locally.

Hardware F

Part name	Description	Photos	Q'ty	Grainger Model #
Hex Screw	3/8 x 3/4"		1	1YU42
Hex Screw	5/16" X 3/4"		1	1YU33
Flat Washer	3/8" x OD23 x 2T		1	*1JY33
Flat Washer	5/16" x OD23 x 2T		1	*1JY31

(* Hardware item at similar spec available locally.

Installations for WB-606612 + SDC-10-6

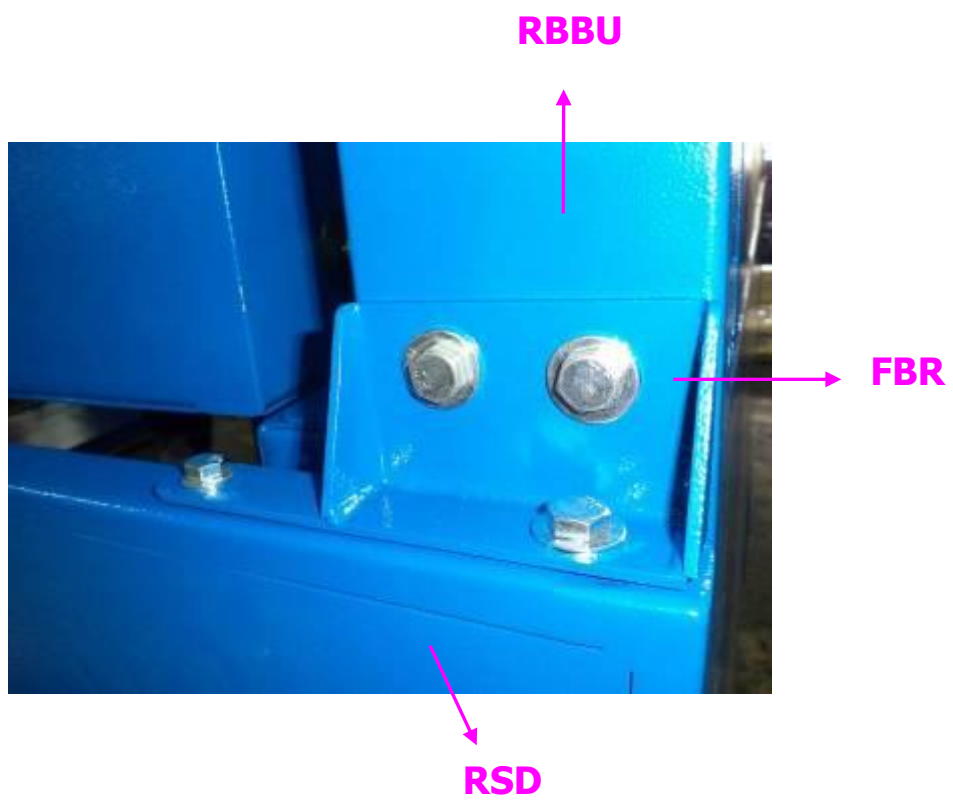
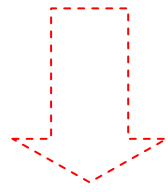
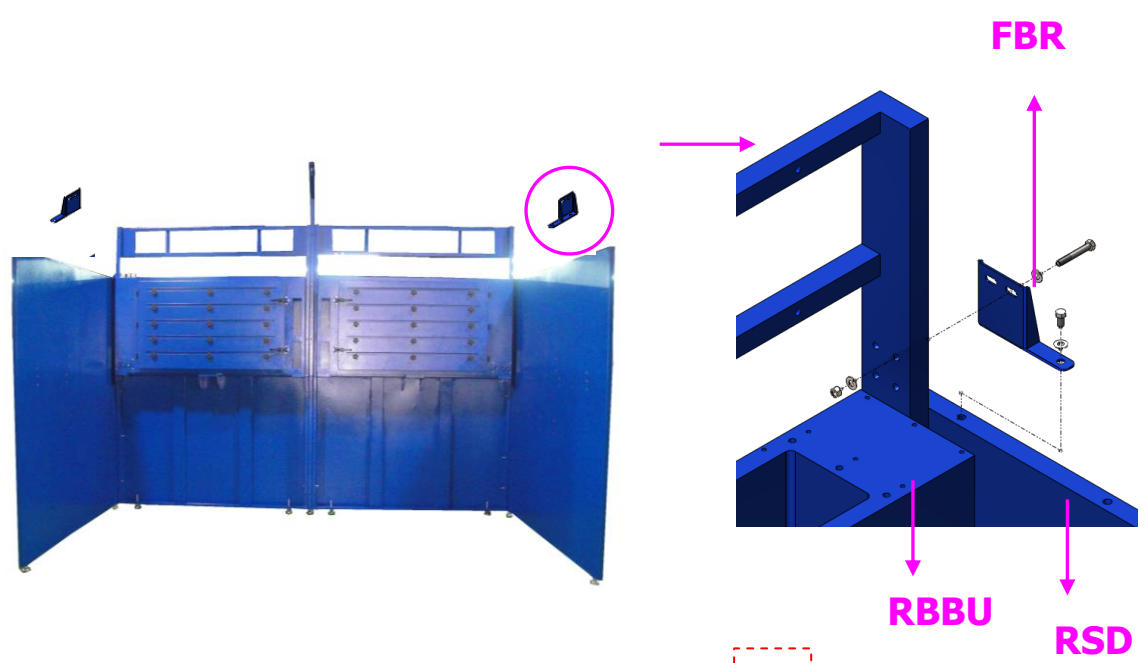

✚ Installations for WB-606612 + SDC-10-6

- Take out the number: **RUSD**
- Join **RUSD** to **RSD** and **RBBU** with:

Hardware N				
Part name	Description	Photos	Q'ty	Grainger Model #
Hex Screw	5/16 x 3/4"		21	1YU33
Flat Washer	5/16" x OD23 x 2T		35	*1JY31
Nylon Hex Nut	5/16"		14	3XTK3

(*) Hardware item at similar spec available locally.

+ Installations for WB-606612 + SDC-10-6

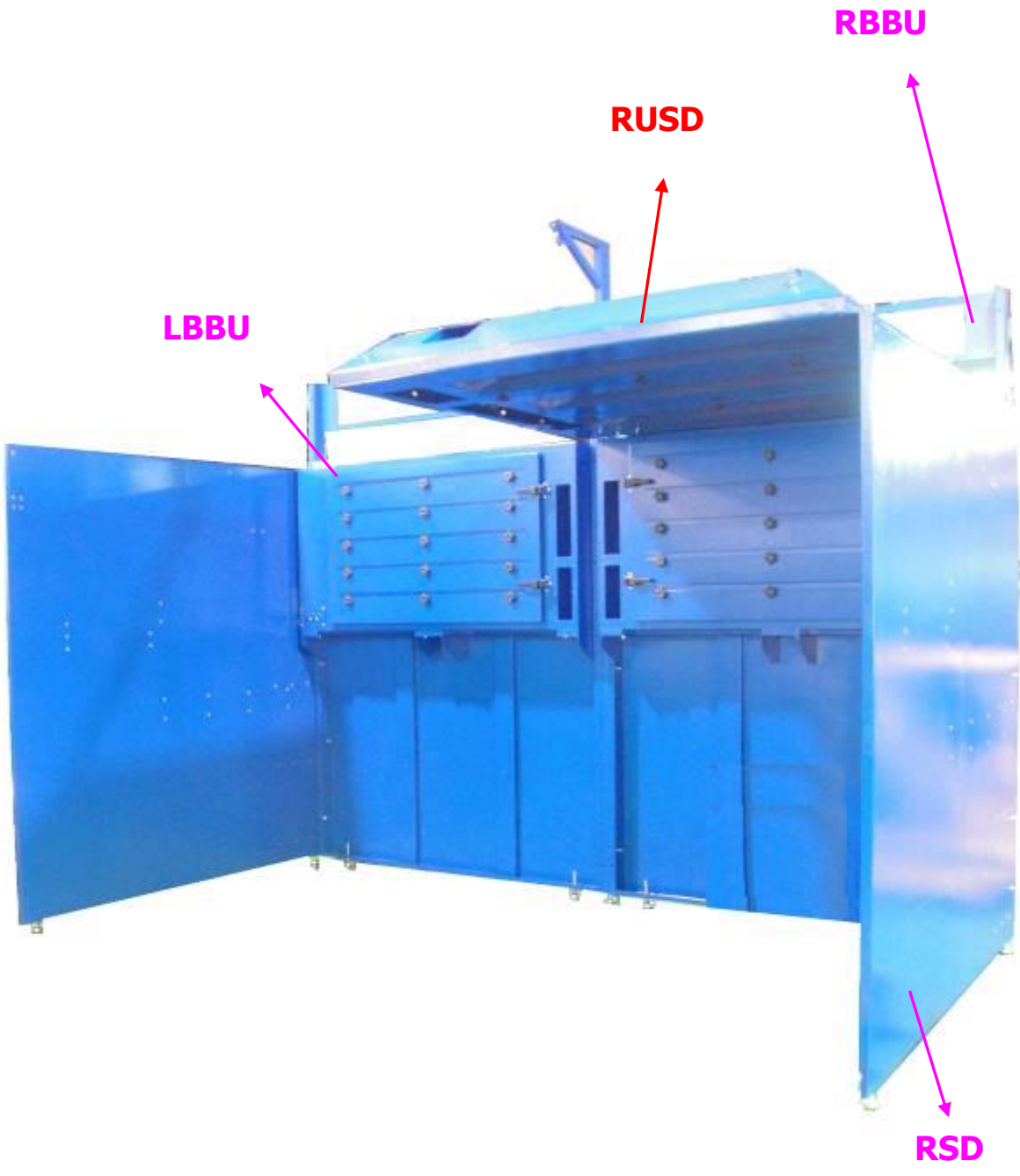

✚ Installations for WB-606612 + SDC-10-6



- Take out the number: **LUSD**
- Join **LUSD** to **LSD** and **LBBU** with:

Hardware N				
Part name	Description	Photos	Q'ty	Grainger Model #
Hex Screw	5/16 x 3/4"		21	1YU33
Flat Washer	5/16" x OD23 x 2T		35	*1JY31
Nylon Hex Nut	5/16"		14	3XTK3

(* Hardware item at similar spec available locally.

✚ Installations for WB-606612 + SDC-10-6

- Join **LUSD** to **RUSD** with:

Hardware M				
Part name	Description	Photos	Q'ty	Grainger Model #
Hex Screw	3/8" x 1"		12	1YU43
Flat Washer	3/8" x OD23 x 2T		24	*1JY33
Nylon Hex Nut	3/8"		12	3HDU4

(* Hardware item at similar spec available locally.

+ Installations for WB-606612 + SDC-10-6

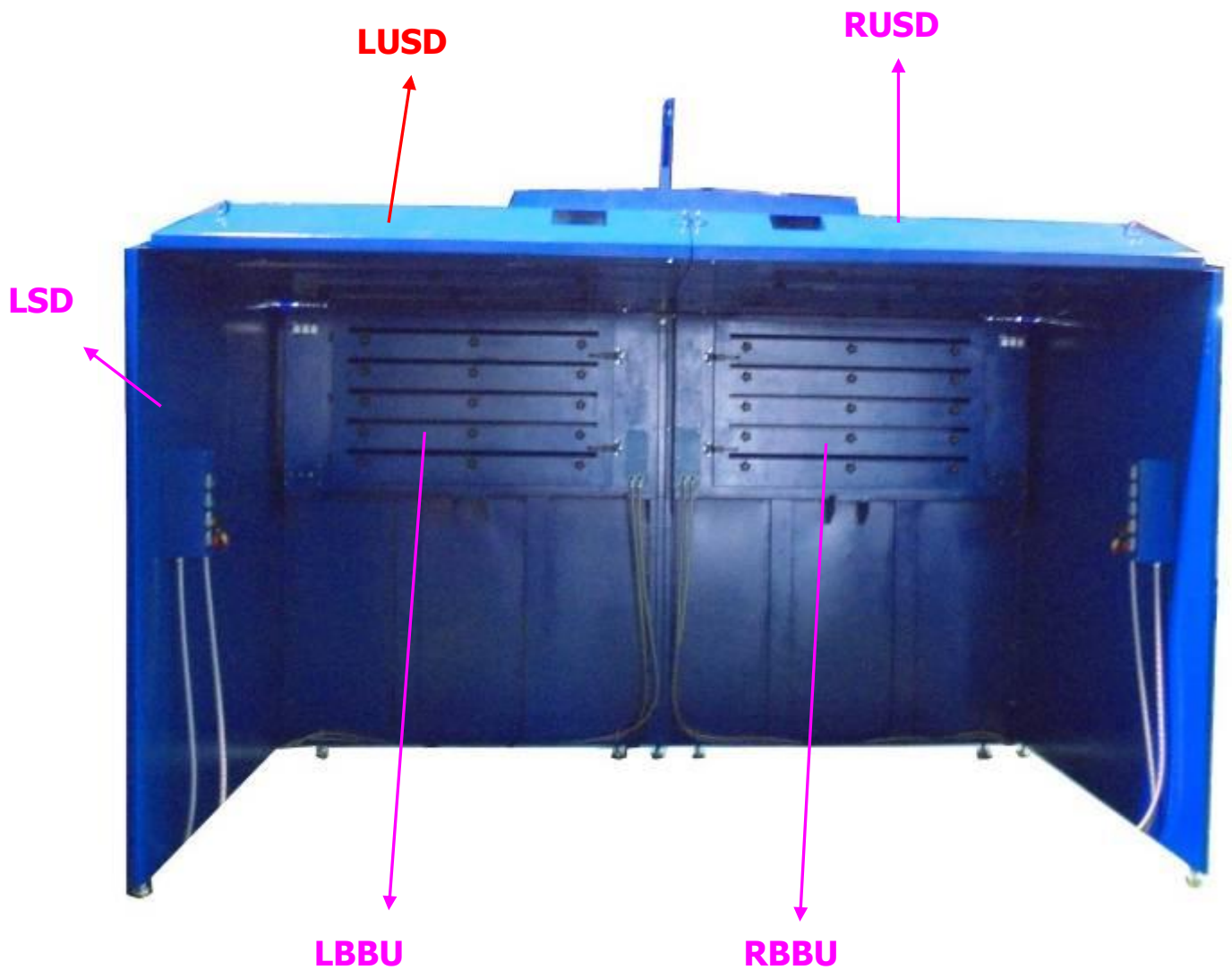

✚ Installations for WB-606612 + SDC-10-6

Take out the number: **SSPJ. BSPJ**

- Fasten **SSPJ. BSPJ** to **LSD** and **RSD** with:

Hardware P				
Part name	Description	Photos	Q'ty	Grainger Model #
Hex Screw	5/16 x 3/4"		8	1YU33
Flat Washer	5/16" x OD23 x 2T		8	*1JY31

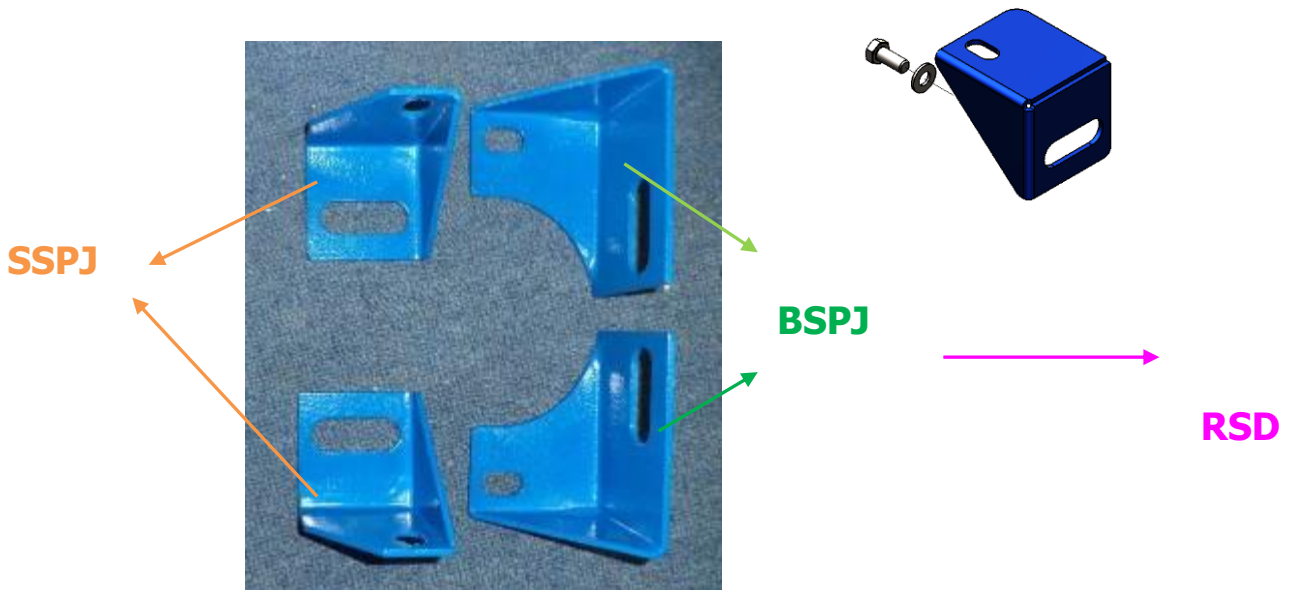
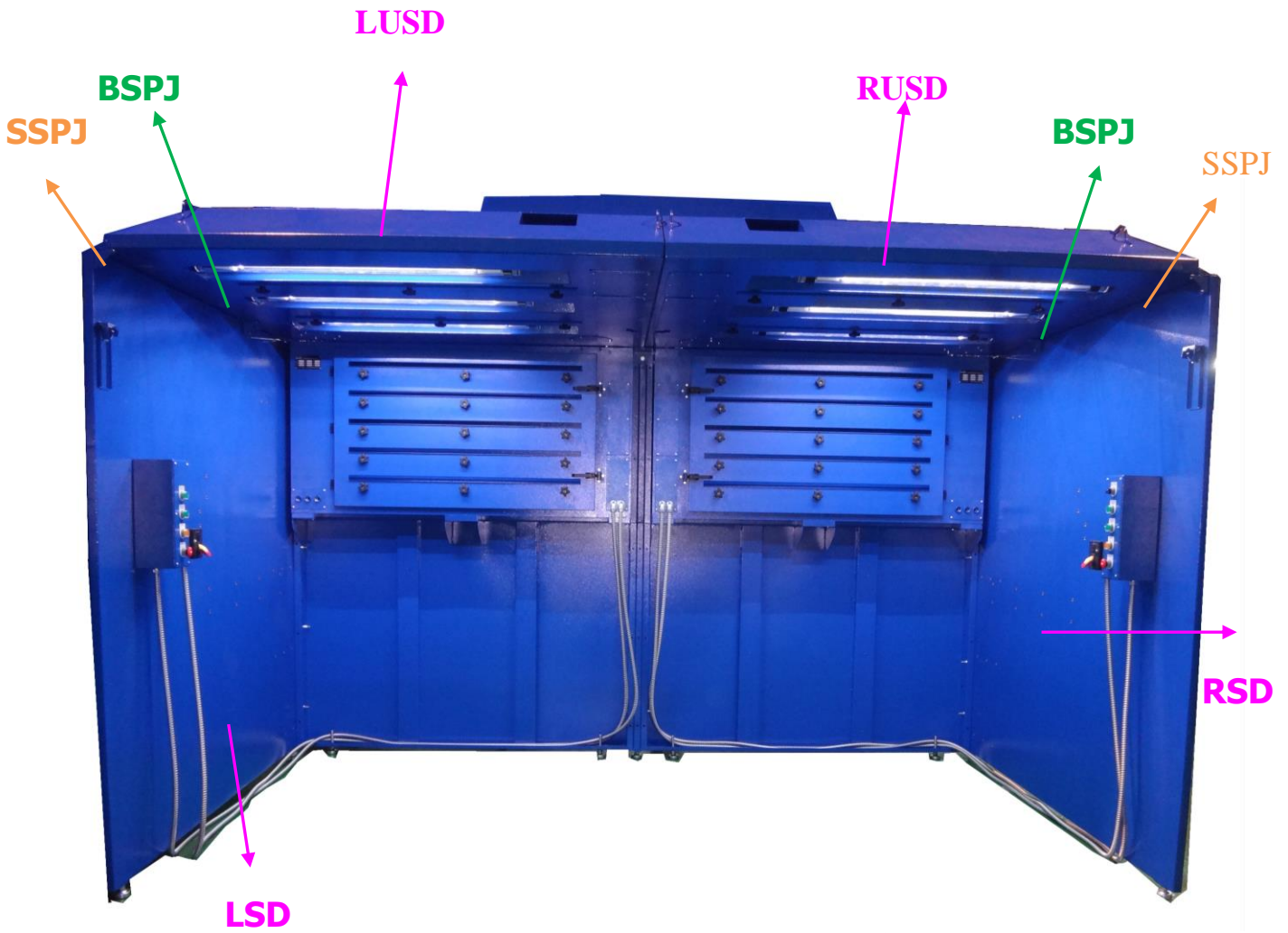

(*) Hardware item at similar spec available locally.

Installations for WB-6055P + SDC-B-3-2.



✚ Installations for WB-606612 + SDC-10-6

- Take out the number: **CR**.
- Fasten **CR** to **LSD** and **RSD** with:

Hardware G				
Part name	Description	Photos	Q'ty	Grainger Model #
Hex Screw	1/4 x 3/4"		16	1YU24
Flat Washer	1/4" x OD19 x 2T		16	*1JY29

(* Hardware item at similar spec available locally.

✚ Installations for WB-6055P + SDC-B-3-2.

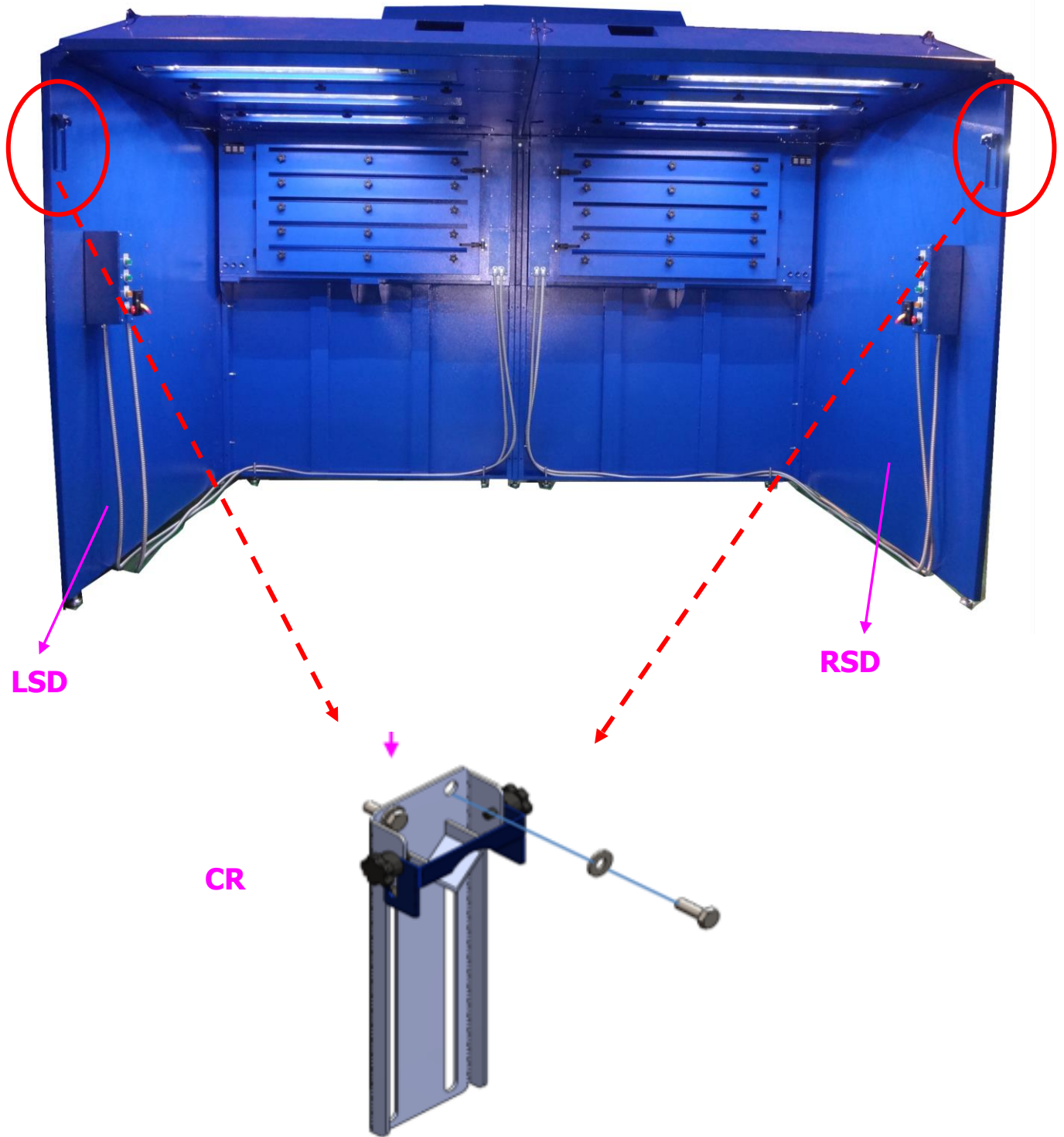

✚ Installations for WB-6055P + SDC-B-3-2.

- Take out the number: **CS**.
- Fasten **CS** to **LSD** and **RSD** with:

Hardware X				
Part name	Description	Photos	Q'ty	Grainger Model #
Hex Screw	5/16 x 3/4"		6	1YU33
Flat Washer	5/16" x OD23 x 2T		6	*1JY31

(*) Hardware item at similar spec available locally.

✚ Installations for WB-6055P + SDC-B-3-2.



✚ Installations for WB-6055P + SDC-B-3-2.

Working Light Combination Instruction

Step 1.

Working Lights completed assembly view-
Top Draft and Back Draft.



Hole on Top Draft.



Install Working Lights wire into the hole which
on the Top Draft as arrow shown.

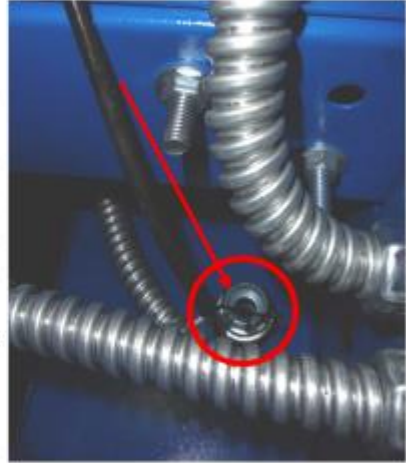

Working Lights wire
on Back Draft.

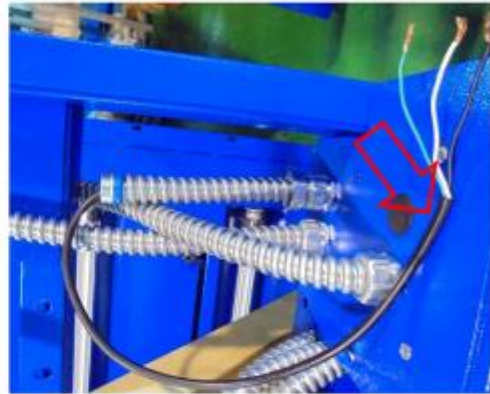

Screw Nuts tightly on both sides.



Complete.



Step 2.

Loosen the screws to open the boards (Left -- Right)

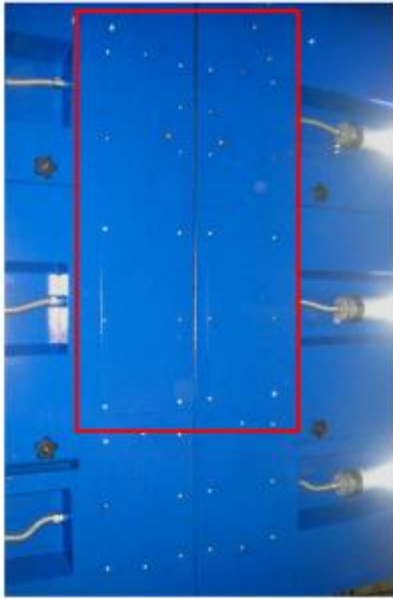

Take off the cover of the adapter by remove the screws.



Wires already combined.

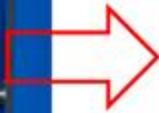

Working Lights wires from Back Draft.



Same color wires combined;
White and White
Black and Black
Green and Green



Lock the boards back and screw tightly.
(Left and Right)



Complete

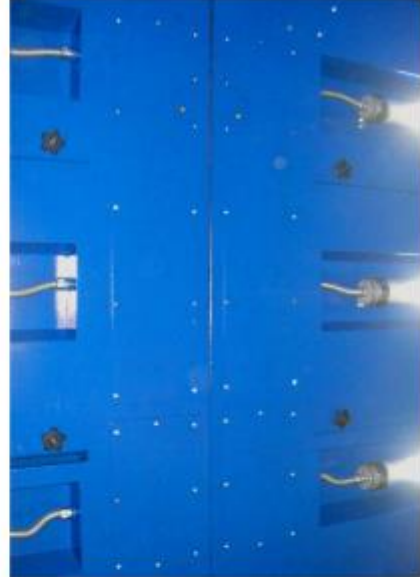

Lock the cover back with screws.
(Left and Right)



Complete



✚ Installations for WB-606612 + SDC-10-6



Step 2.



+ Installations for WB-606612 + SDC-10-6

Take out the number: **HEPA**

- Fasten **HEPA** to **MACHINE** with:

Hardware W				
Part name	Description	Photos	Q'ty	Grainger Model #
Hex Screw	3/8" x 1"		12	1YU43
Flat Washer	3/8" x OD23 x 2T		12	*1JY33

(* Hardware item at similar spec available locally.

+ Installations for WB-606612 + SDC-10-6

HEPA

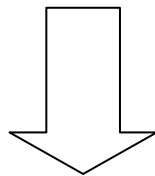

MACHINE

✦ Installations for WB-606612 + SDC-10-6

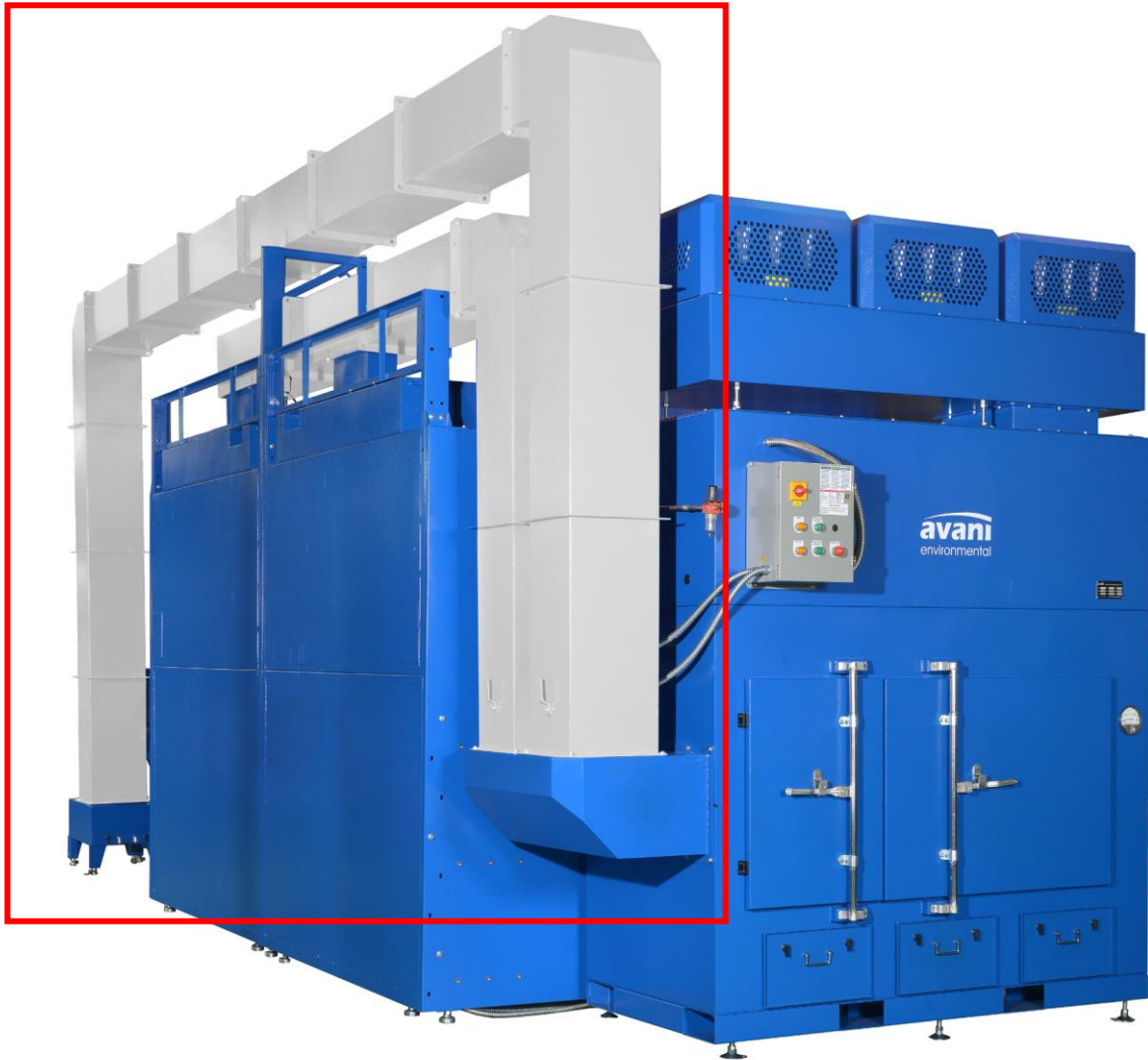

Step 3.



✚ Installations for WB-606612 + SDC-10-6

Take out the number: **C1**

- Fasten **C1** to **MACHINE** with:

Hardware T				
Part name	Description	Photos	Q'ty	Grainger Model #
Hex Screw	3/8" x 1"		16	1YU43
Flat Washer	3/8" x OD23 x 2T		16	*1JY33

(*) Hardware item at similar spec available locally.

✚ Installations for WB-606612 + SDC-10-6

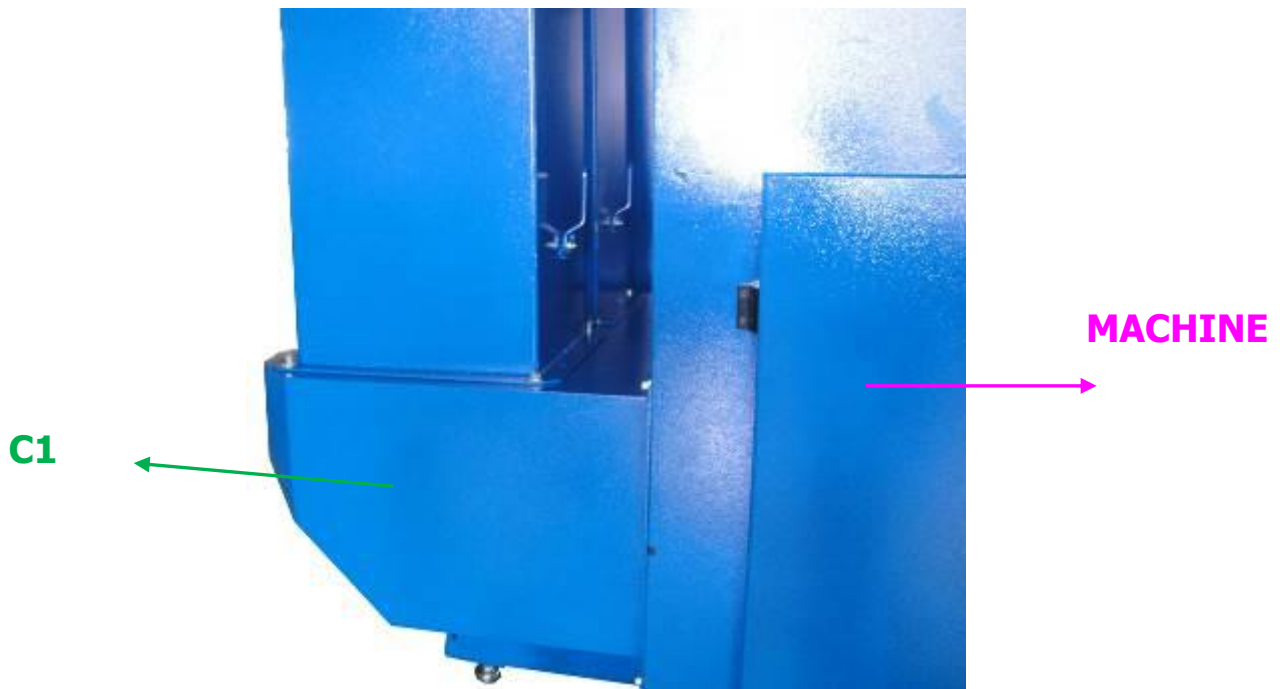
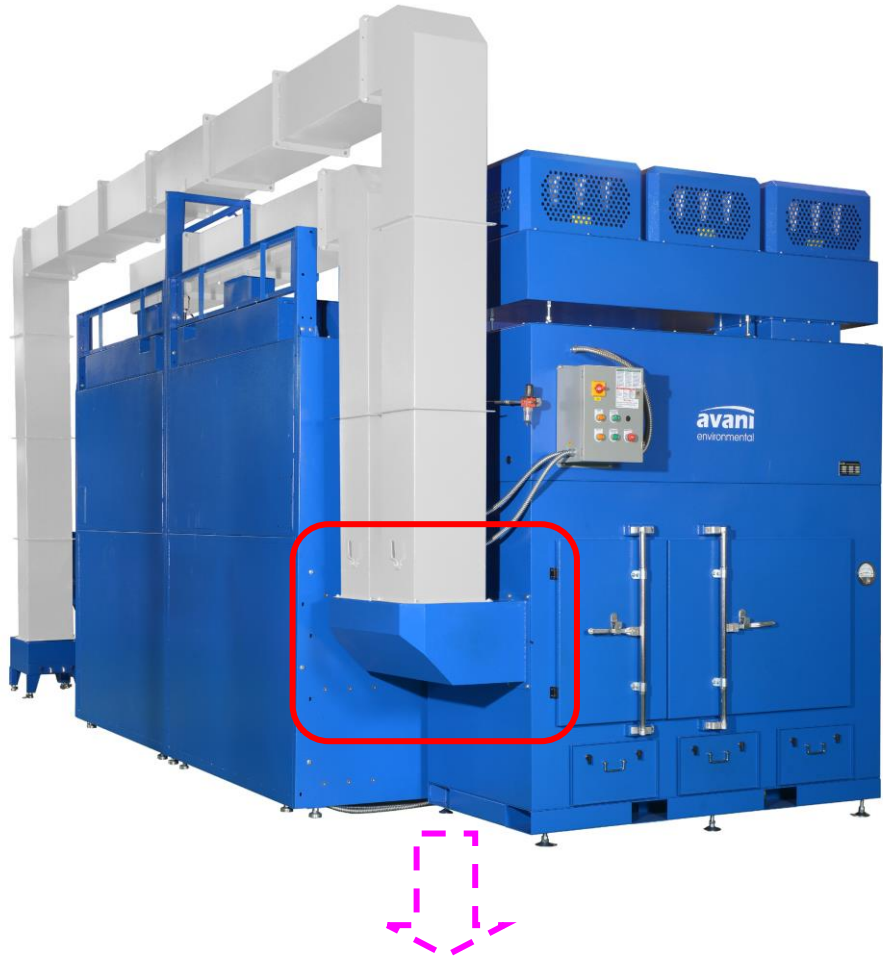

✚ Installations for WB-606612 + SDC-10-6

- Take out the number: **A1** and **B1**.
- Fasten **A1** and **B1** to **C1** with:

Hardware R				
Part name	Description	Photos	Q'ty	Grainger Model #
Hex Screw	5/16 x 3/4"		20	1YU33
Flat Washer	5/16" x OD23 x 2T		20	*1JY31

(* Hardware item at similar spec available locally.

✦ Installations for WB-606612 + SDC-10-6

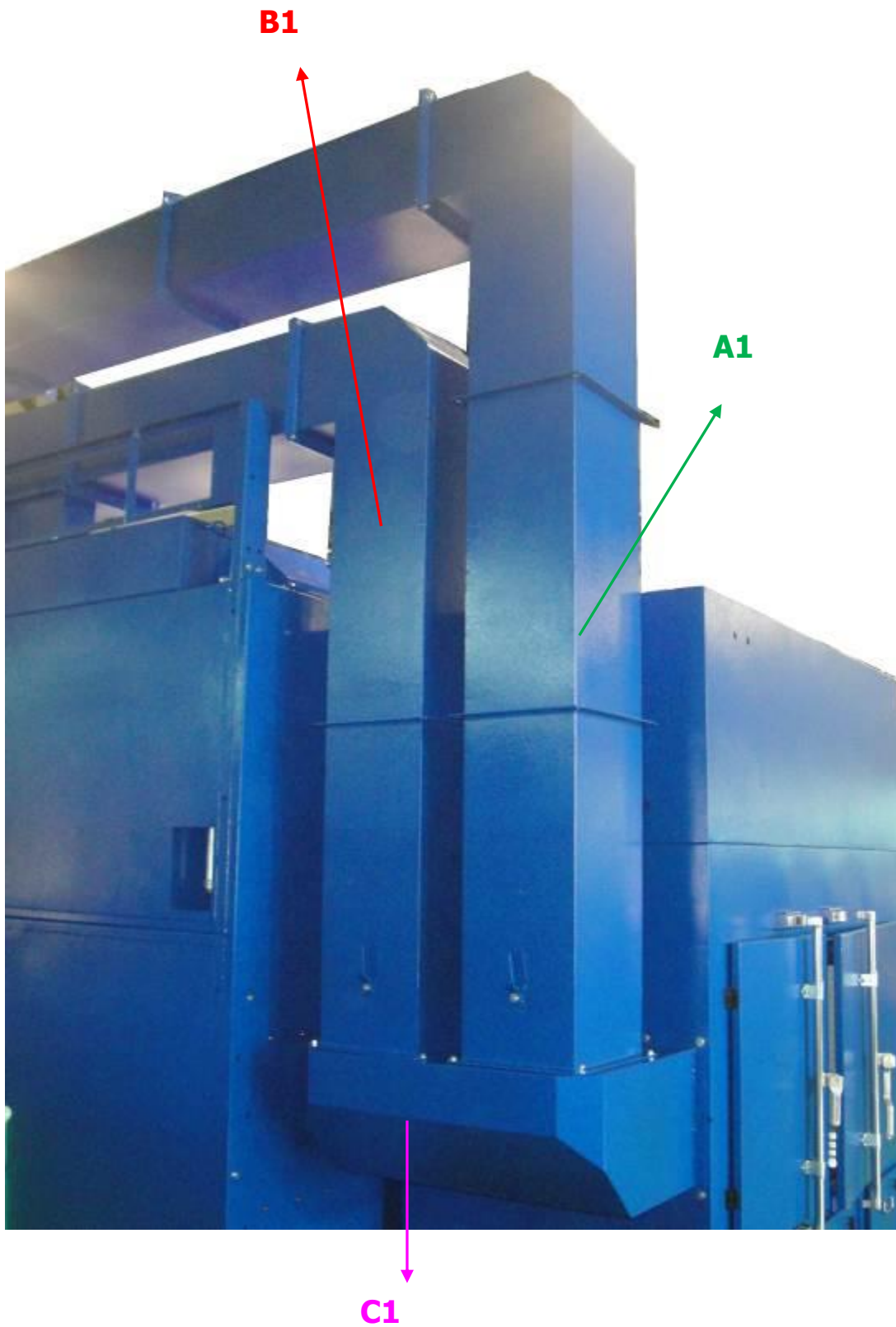

✚ Installations for WB-606612 + SDC-10-6

- Take out the number: **B2**.
- Fasten **B2** to **B1** with:

Hardware Q				
Part name	Description	Photos	Q'ty	Grainger Model #
Hex Screw	5/16 x 1"		10	1YU34
Flat Washer	5/16" x OD23 x 2T		20	*1JY31
Nylon Hex Nut	5/16"		10	3XTK3

(* Hardware item at similar spec available locally.

✚ Installations for WB-606612 + SDC-10-6

B2

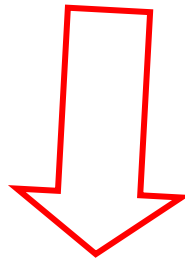

A1

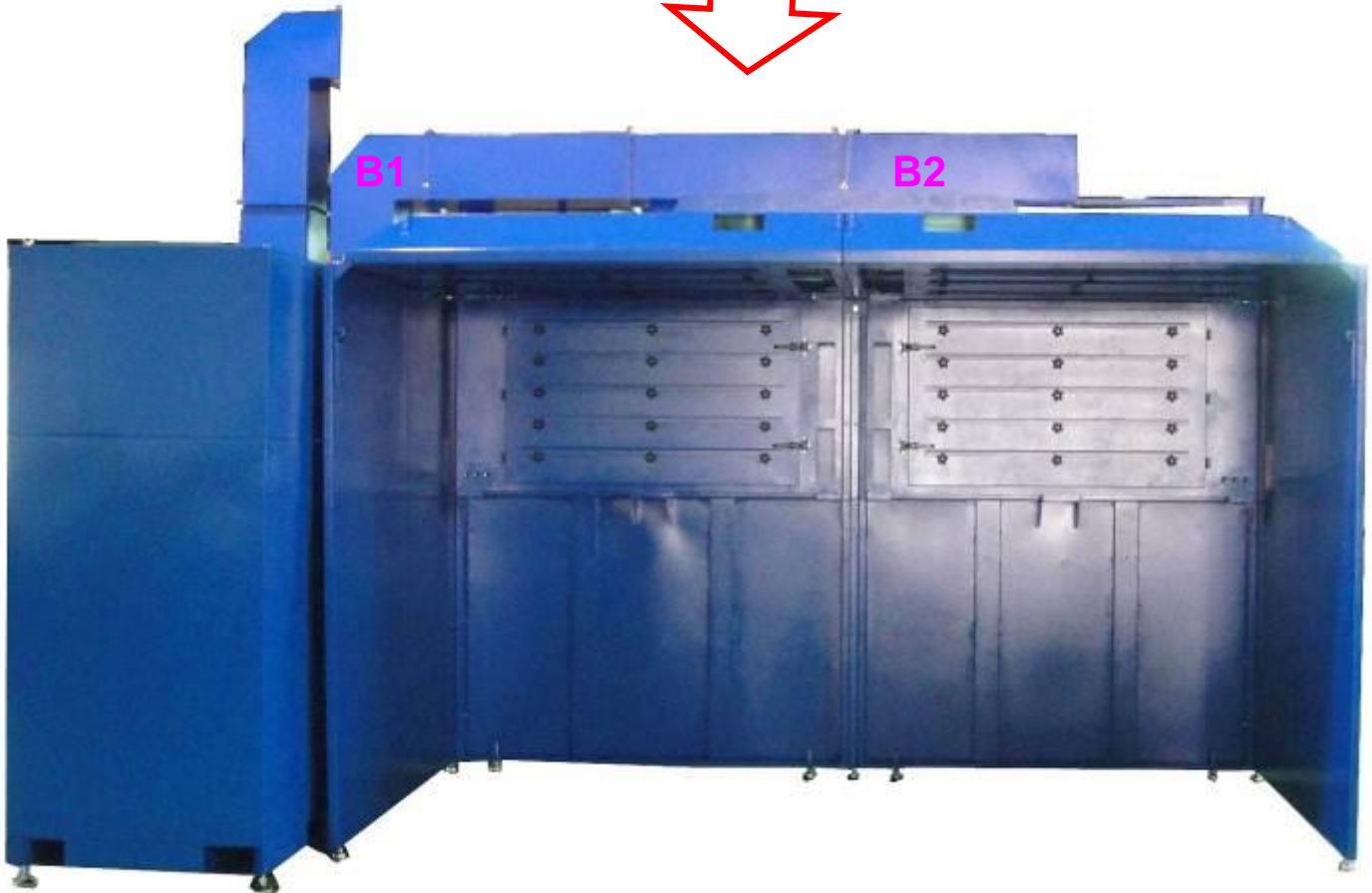

B1

B2



✚ Installations for WB-606612 + SDC-10-6

- Take out the number: **B3** and **B4**
- Fasten **B3** to **B2** and **LUSD** with:
- Fasten **B4** to **B2** and **RUSD** with:

Hardware R				
Part name	Description	Photos	Q'ty	Grainger Model #
Hex Screw	5/16 x 3/4"		32	1YU33
Flat Washer	5/16" x OD23 x 2T		32	*1JY31

(*) Hardware item at similar spec available locally.

✚ Installations for WB-606612 + SDC-10-6

B3 / B4

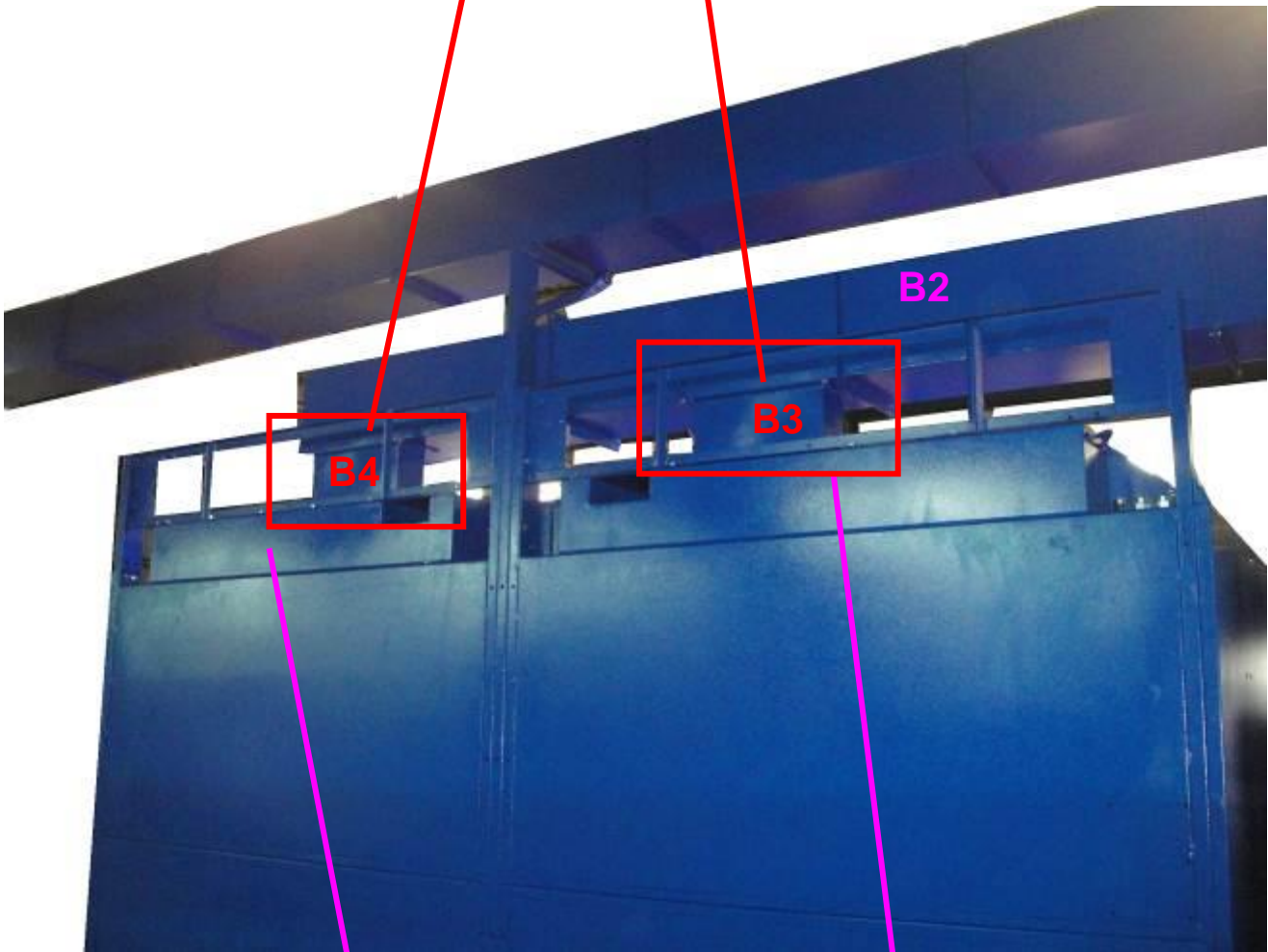

B4

B3

B2

RUSD

LUSD

✚ Installations for WB-606612 + SDC-10-6

- Take out the number: **A4** and **A5**.
- Fasten **A4** to **A5** with:

Hardware Q				
Part name	Description	Photos	Q'ty	Grainger Model #
Hex Screw	5/16 x 1"		10	1YU34
Flat Washer	5/16" x OD23 x 2T		20	*1JY31
Nylon Hex Nut	5/16"		10	3XTK3

(*) Hardware item at similar spec available locally.

✚ Installations for WB-606612 + SDC-10-6

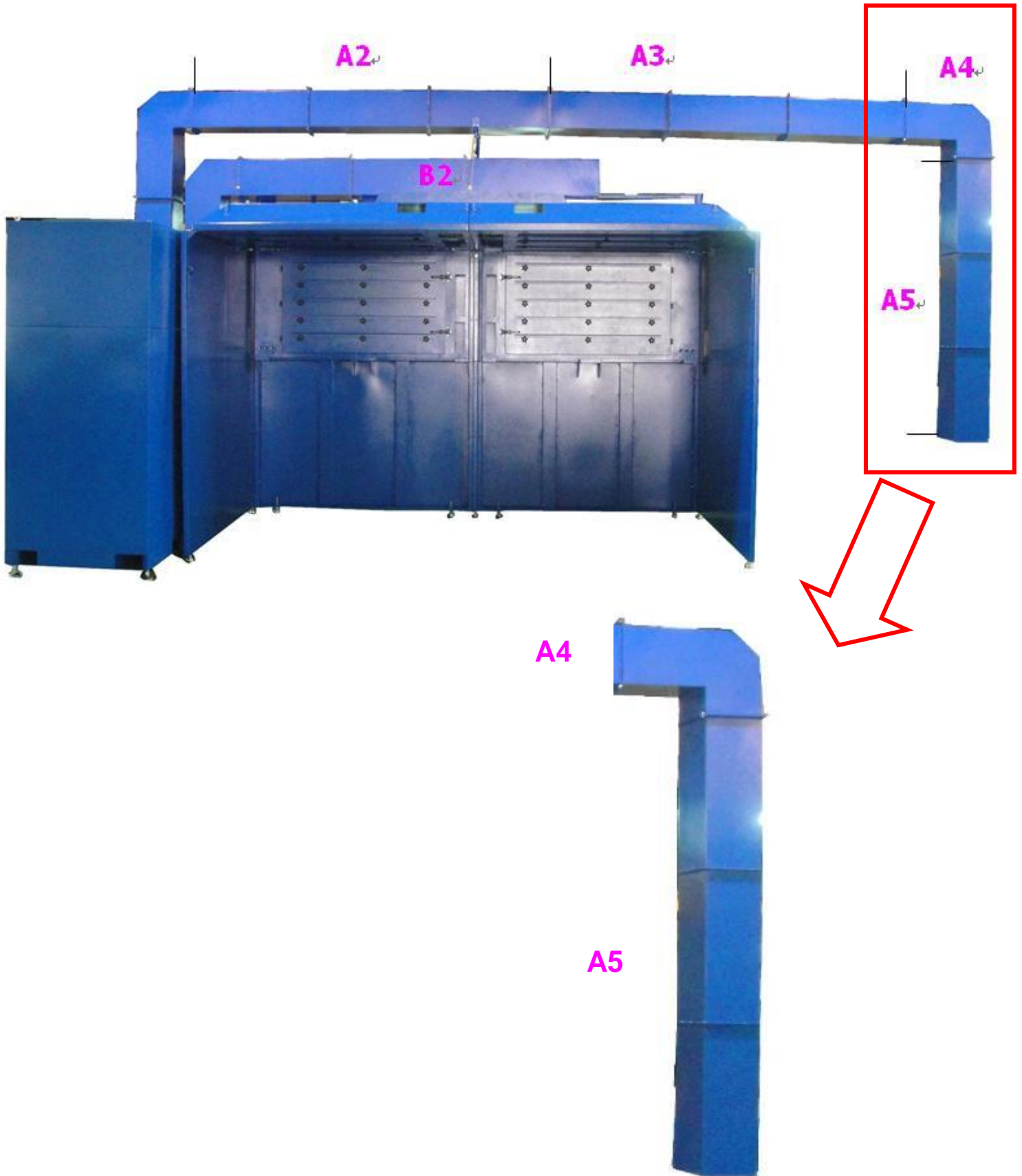

✚ Installations for WB-606612 + SDC-10-6

- Take out the number: **A2** and **A3**.
- Fasten **A2** to **A3** with:

Hardware Q				
Part name	Description	Photos	Q'ty	Grainger Model #
Hex Screw	5/16 x 1"		10	1YU34
Flat Washer	5/16" x OD23 x 2T		20	*1JY31
Nylon Hex Nut	5/16"		10	3XTK3

(*) Hardware item at similar spec available locally.

Installations for WB-606612 + SDC-10-6

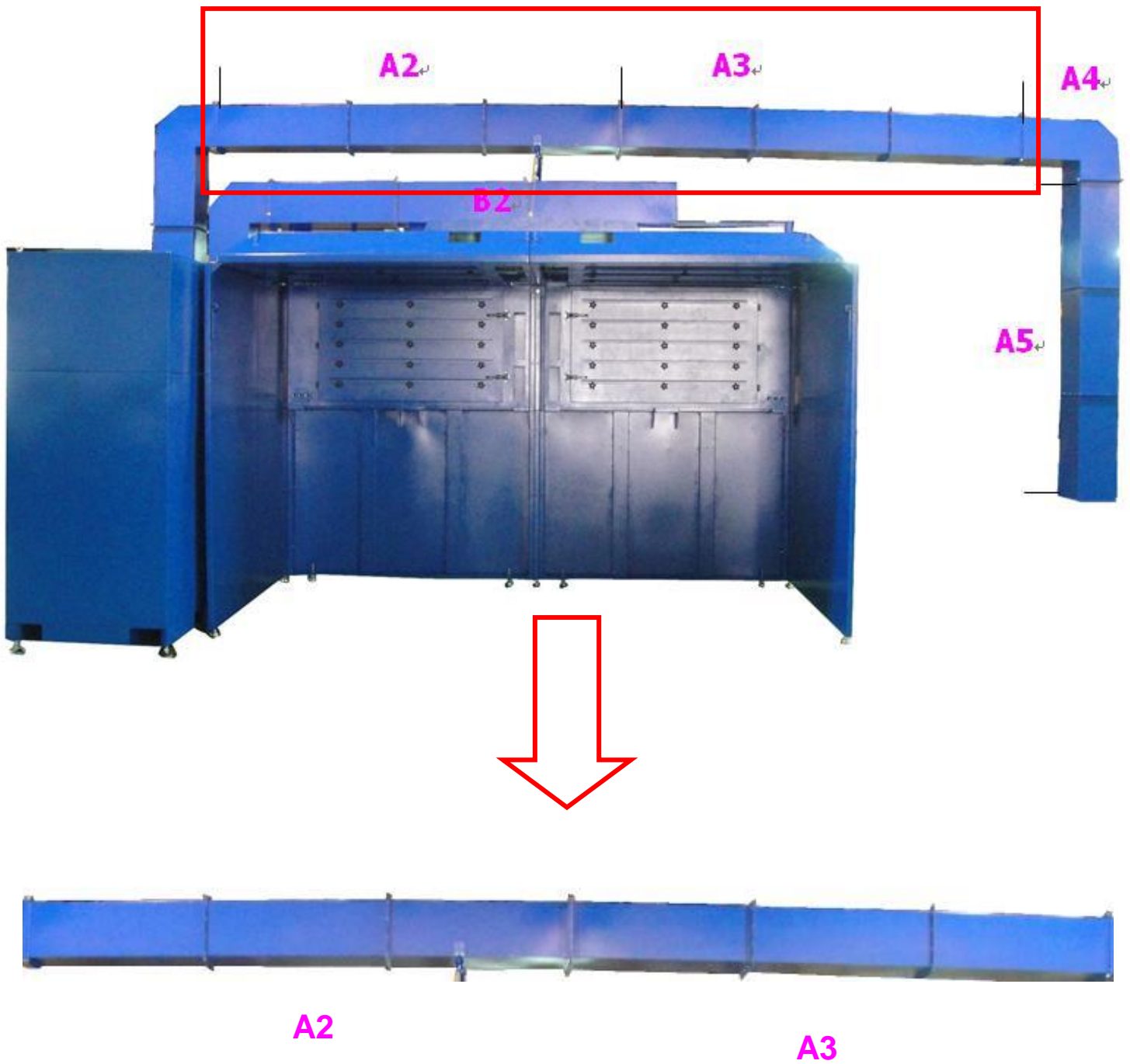

✚ Installations for WB-606612 + SDC-10-6

- Fasten **A1** to **A2** with:
- Fasten **A3** to **A4** with:

Hardware Q				
Part name	Description	Photos	Q'ty	Grainger Model #
Hex Screw	5/16 x 1"		20	1YU34
Flat Washer	5/16" x OD23 x 2T		40	*1JY31
Nylon Hex Nut	5/16"		20	3XTK3

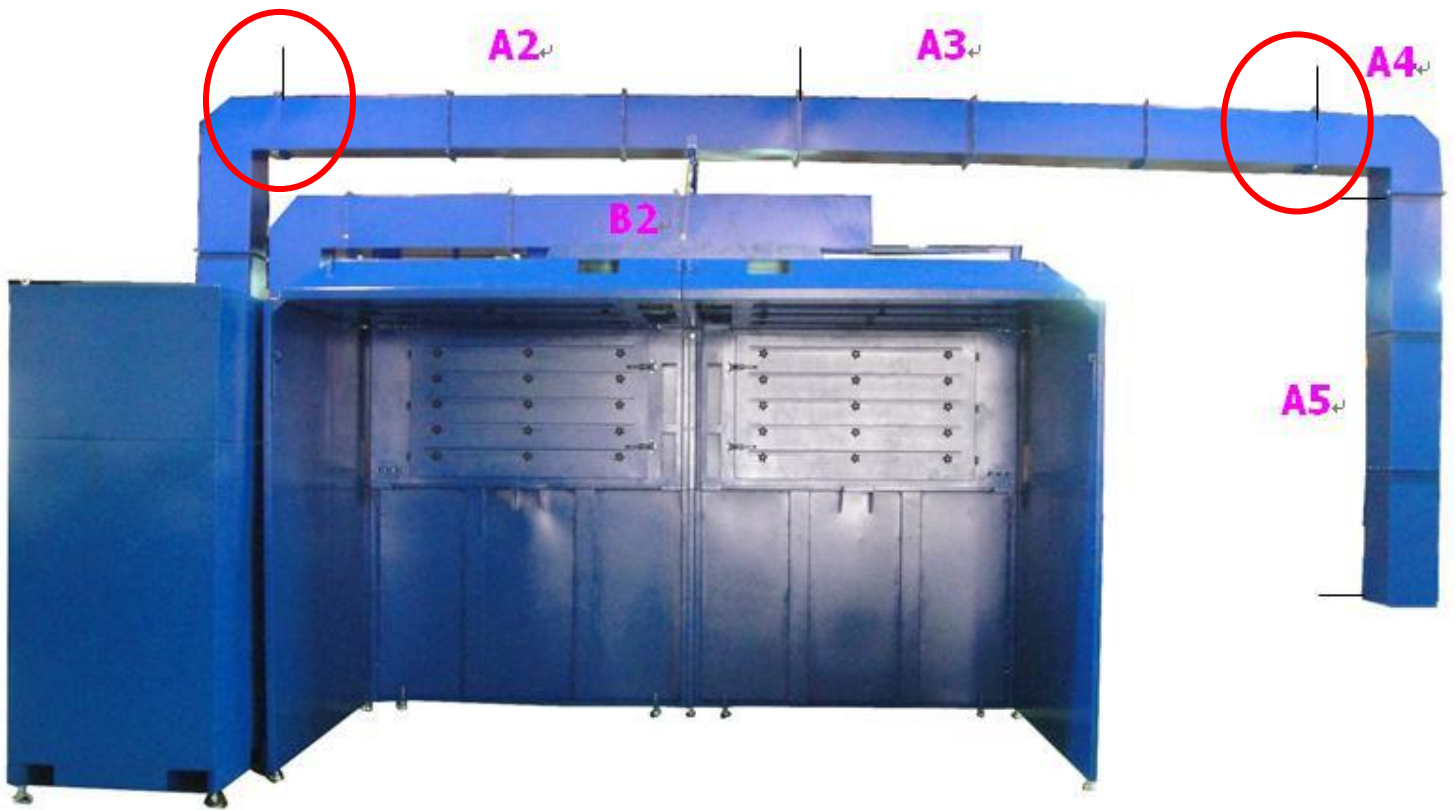

(*) Hardware item at similar spec available locally.

✚ Installations for WB-606612 + SDC-10-6



+ Installations for WB-606612 + SDC-10-6



- Take out the number: **TH** and **TU**
- Fasten **TU** to **MSDU** and **A2** with:

Hardware Z				
Part name	Description	Photos	Q'ty	Grainger Model #
Hex Screw	3/8 x 3/4"		4	1YU42
Flat Washer	3/8" x OD23 x 2T		4	*1JY33

(*) Hardware item at similar spec available locally.

✚ Installations for WB-606612 + SDC-10-6

- Fasten **TH** to **LUSD** and **RUSD** with:

Hardware Y				
Part name	Description	Photos	Q'ty	Grainger Model #
Hex Screw	1/2" x 1"		20	1YU42
Flat Washer	1/2" x OD28 x 3T		20	*1JY35

(*) Hardware item at similar spec available locally.

✚ Installations for WB-606612 + SDC-10-6

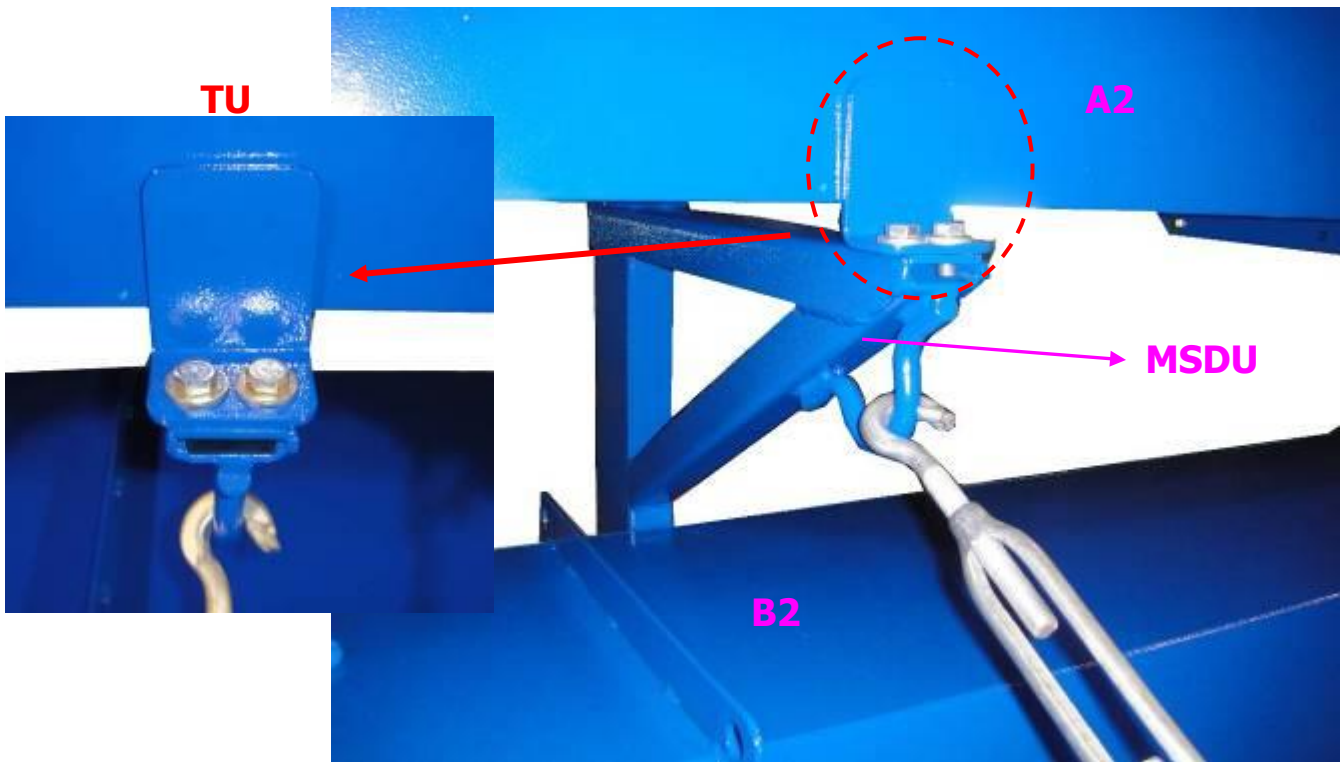

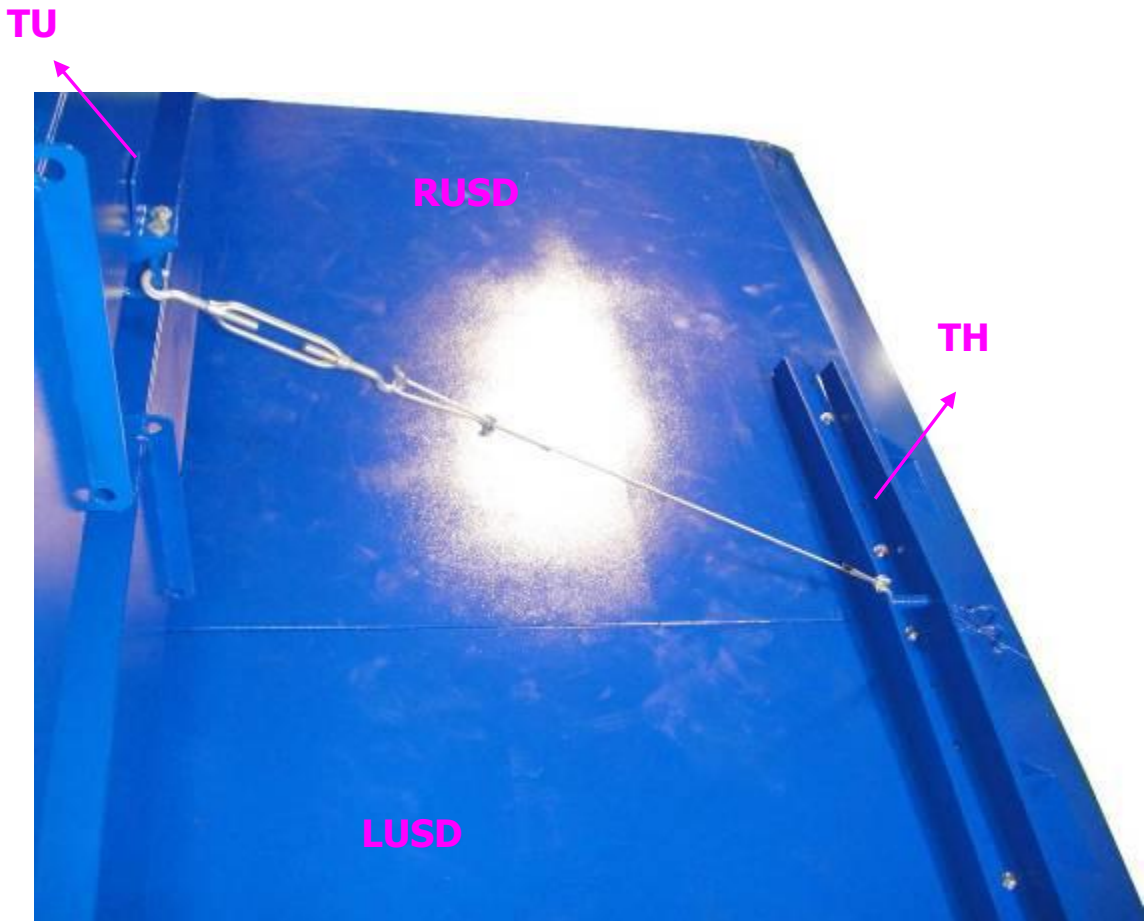
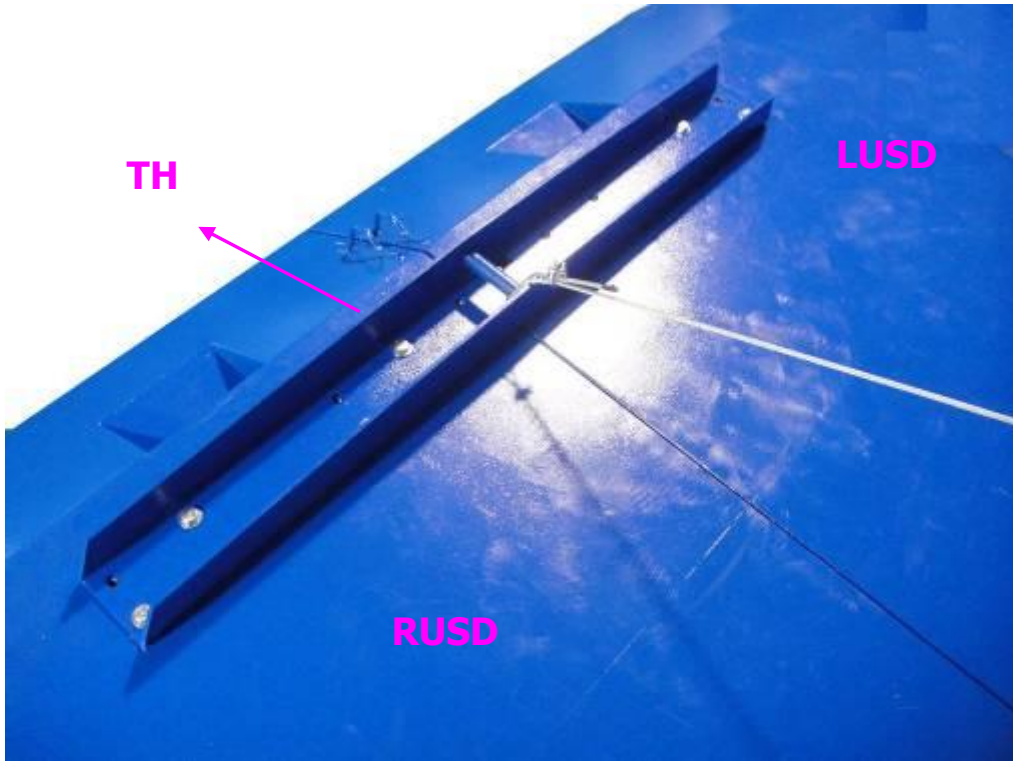

+ Installations for WB-606612 + SDC-10-6



+ Installations for WB-606612 + SDC-10-6

- Take out the number: **A6**
- Fasten **A6** to **A5** with:

Hardware R				
Part name	Description	Photos	Q'ty	Grainger Model #
Hex Screw	5/16 x 3/4"		10	1YU33
Flat Washer	5/16" x OD23 x 2T		10	*1JY31

(* Hardware item at similar spec available locally.

✚ Installations for WB-606612 + SDC-10-6

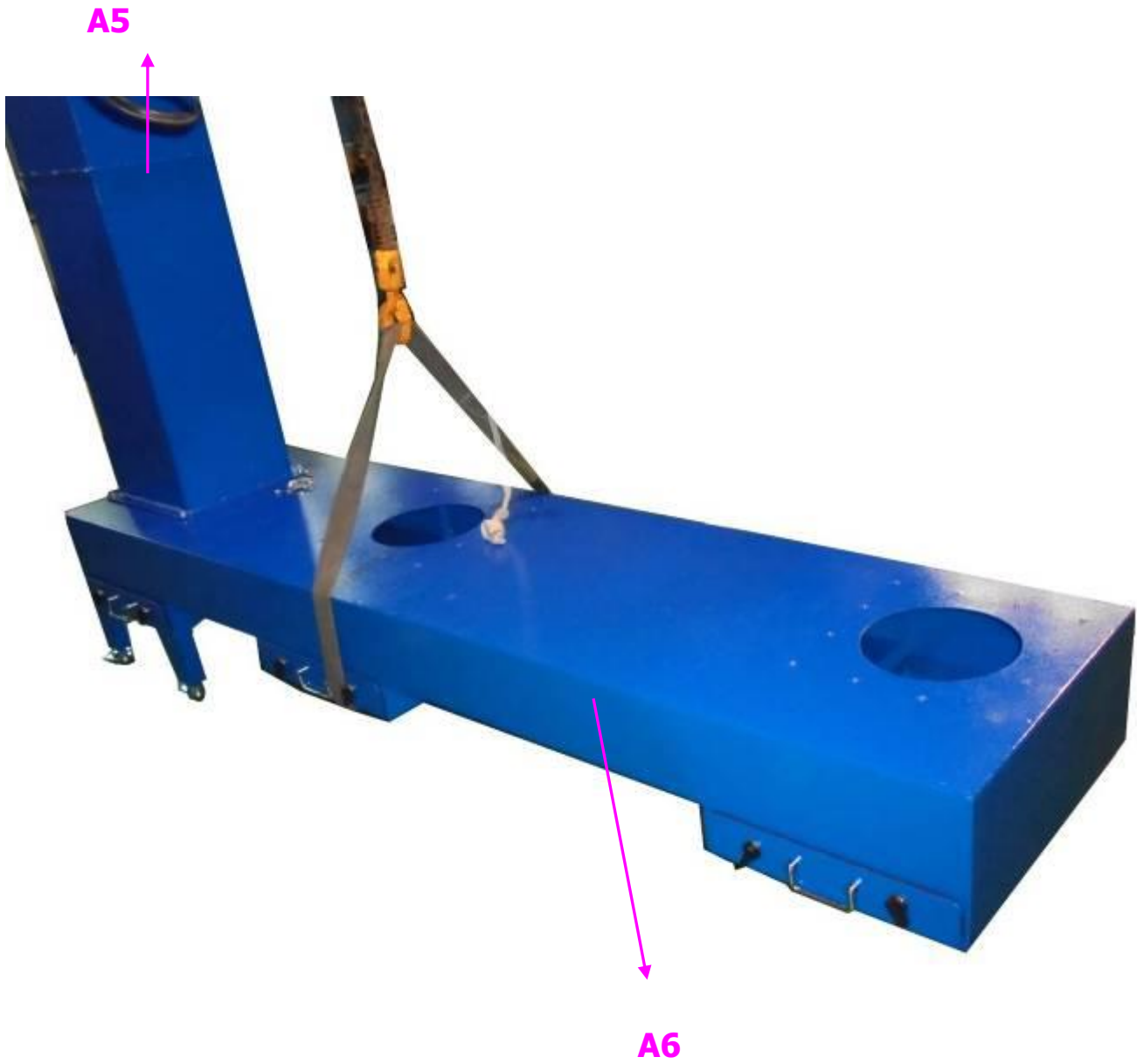

✚ Installations for WB-606612 + SDC-10-6

Step 4.



✚ Installations for WB-606612 + SDC-10-6

- Take out the number: **TABLE – Side plate**
- Fasten **TABLE – Side plate** to **WORKING TABLE** with:

Hardware U				
Part name	Description	Photos	Q'ty	Grainger Model #
Hex Screw	5/16 x 3/4"		68	1YU33
Flat Washer	5/16" x OD18 x 2T		68	*1JY31

(*) Hardware item at similar spec available locally.

✦ Installations for WB-606612 + SDC-10-6

TABLE – Side plate

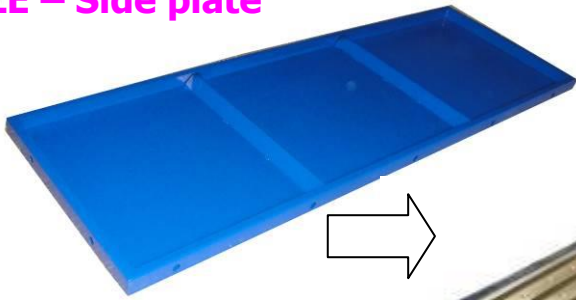

Working Table

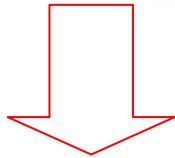

+ Installations for WB-606612 + SDC-10-6

**Working
Table**



Put two Working Tables side by side.



✦ Installations for WB-606612 + SDC-10-6

Center side panels can be removed to increase working area

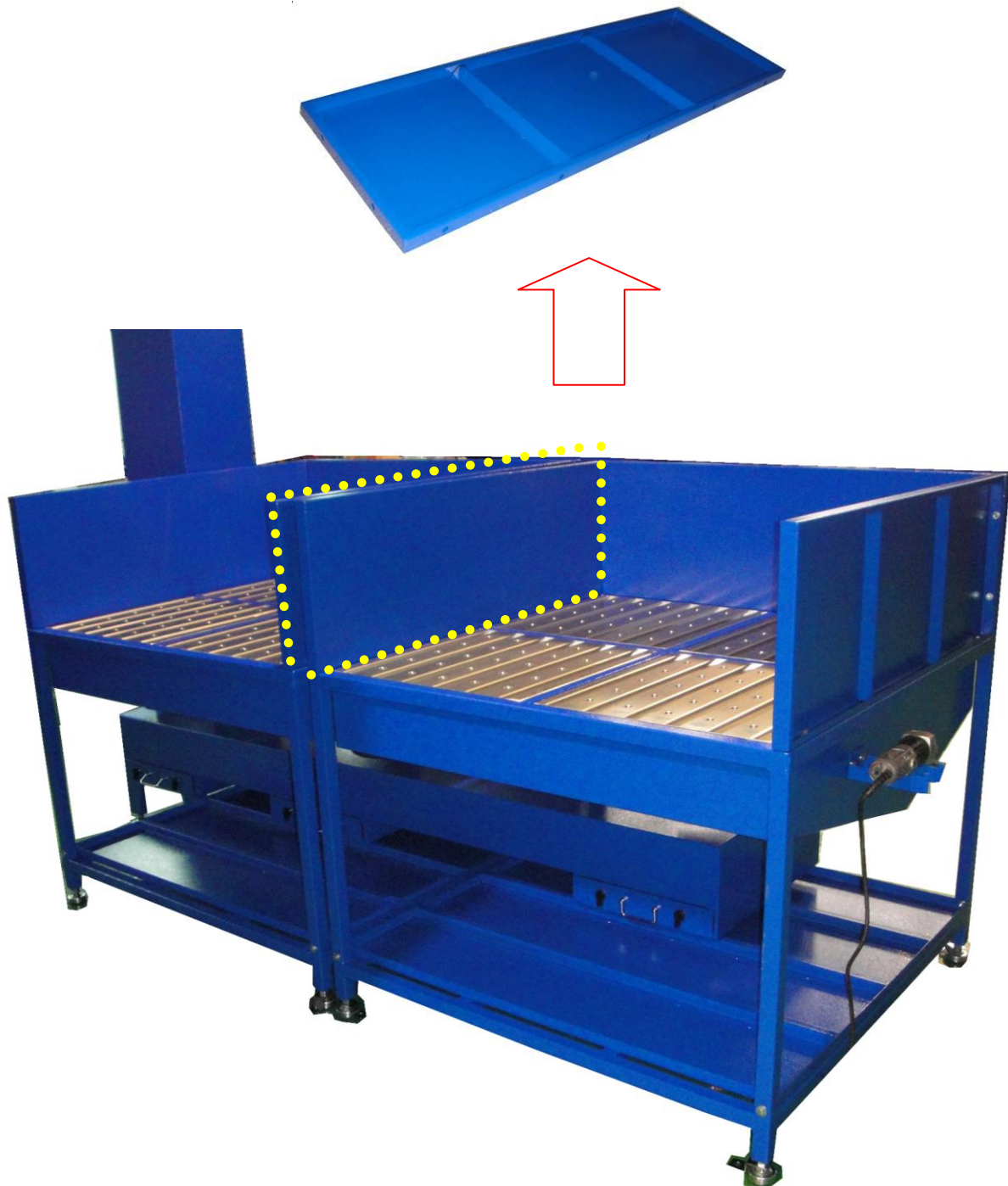

+ Installations for WB-606612 + SDC-10-6

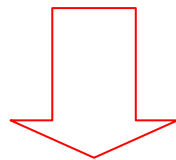
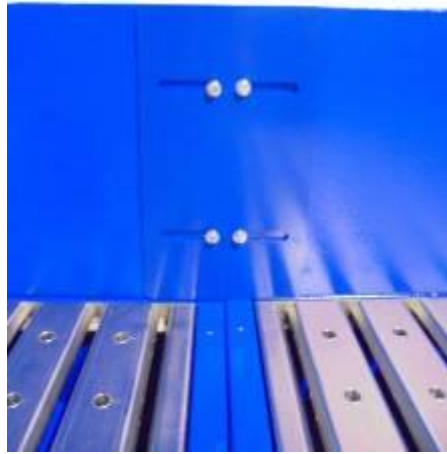

✚ Installations for WB-606612 + SDC-10-6

- Take out the number: **INTAKE**
- Fasten **INTAKE** to **WORKING TABLE** with:

Hardware U				
Part name	Description	Photos	Q'ty	Grainger Model #
Hex Screw	5/16 x 3/4"		40	1YU33
Flat Washer	5/16" x OD18 x 2T		40	*1JY31

(*) Hardware item at similar spec available locally.

+ Installations for WB-606612 + SDC-10-6

Combination

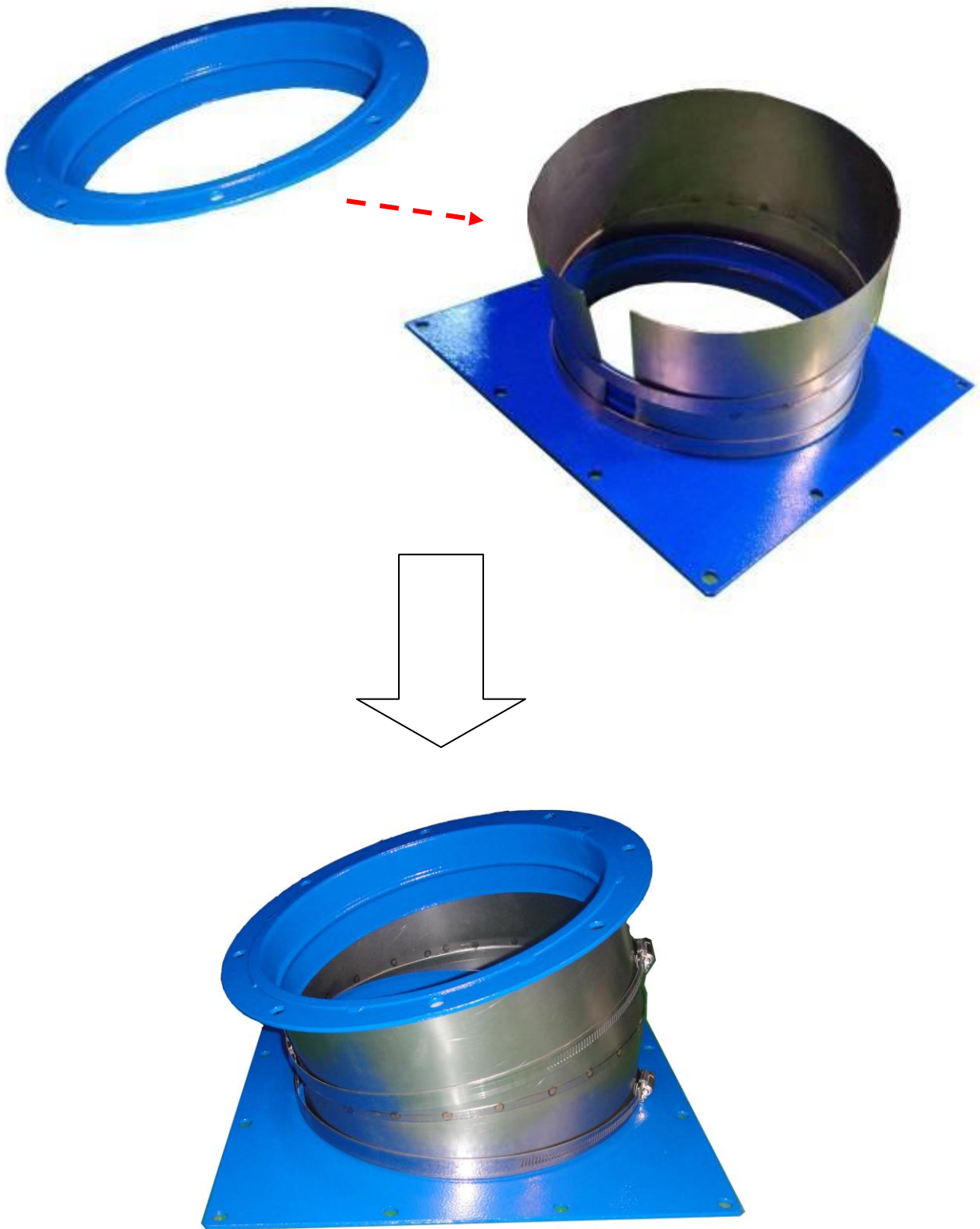

✚ Installations for WB-606612 + SDC-10-6

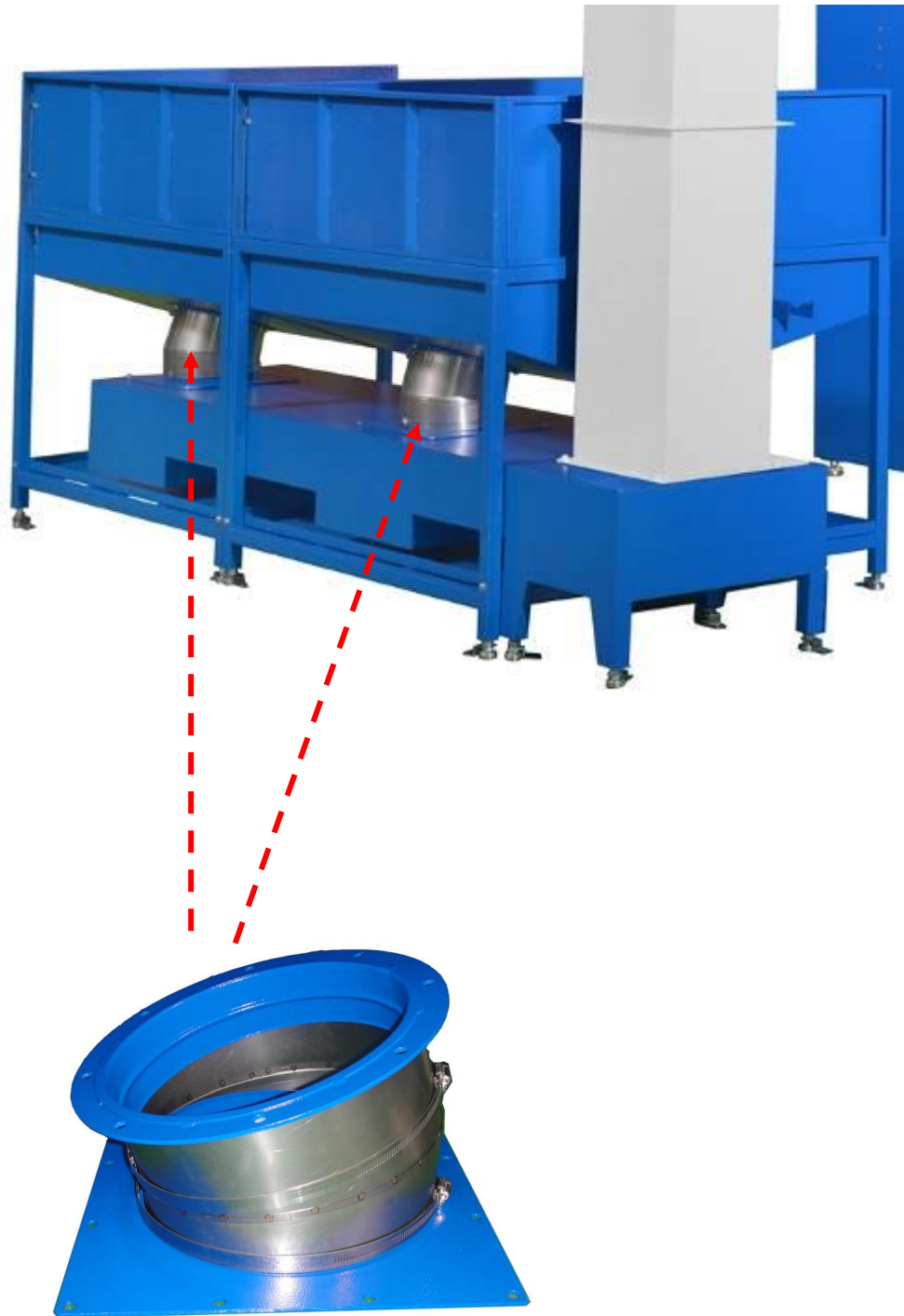

✚ Installations for WB-606612 + SDC-10-6

- Take out the number: **EW**
- Fasten **EW** to **TABLE** with:

Hardware V				
Part name	Description	Photos	Q'ty	Grainger Model #
Hex Screw	5/16 x 3/4"		4	1YU33
Flat Washer	5/16" x OD18 x 2T		4	*1JY31

(* Hardware item at similar spec available locally.

+ Installations for WB-606612 + SDC-10-6

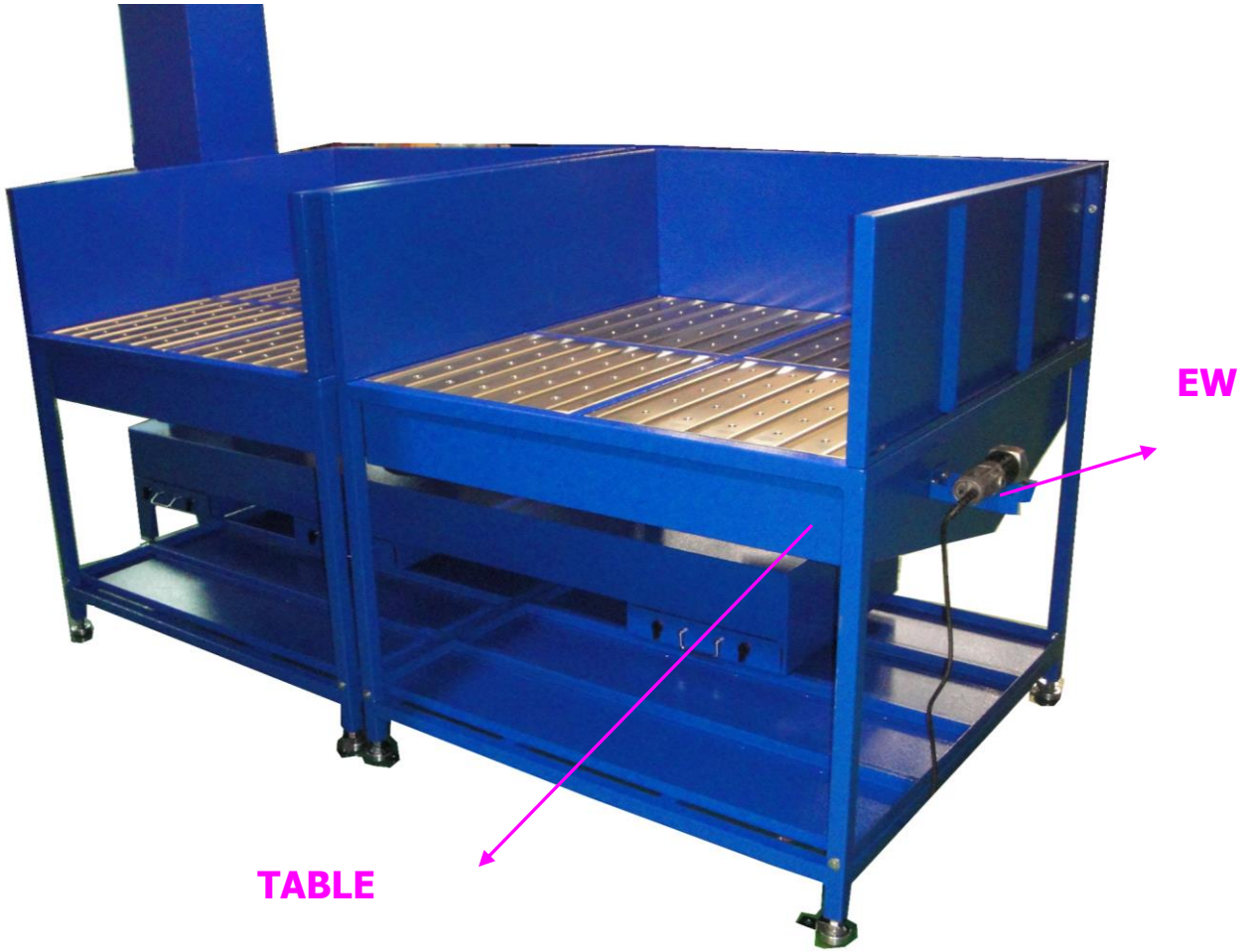

+ Installations for WB-606612 + SDC-10-6



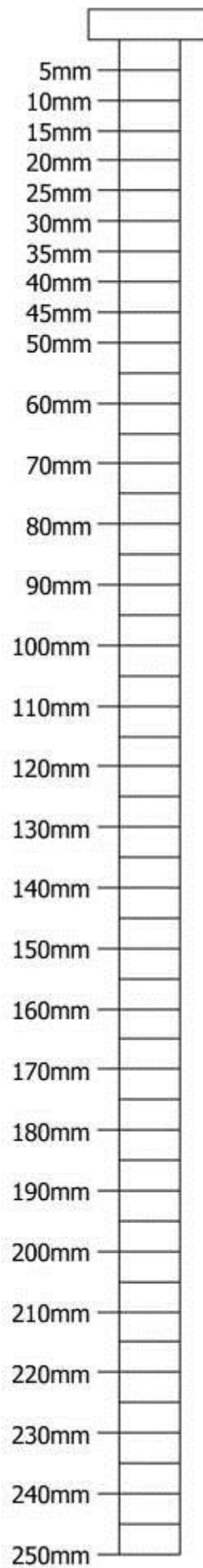
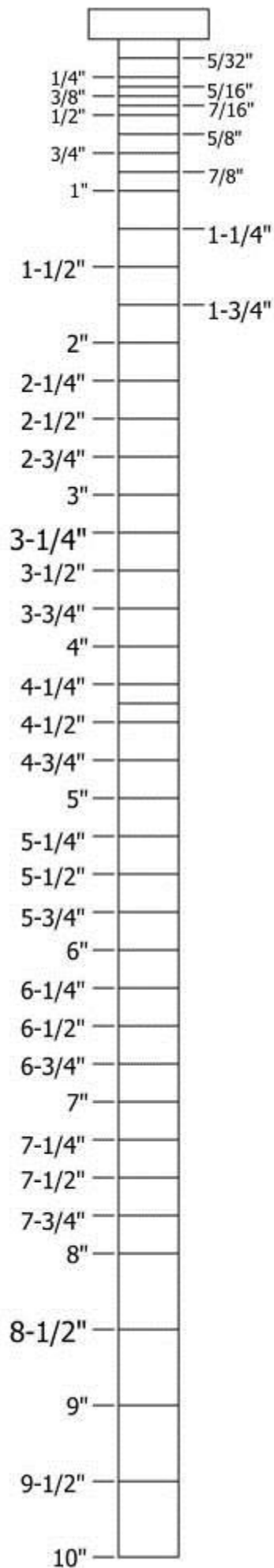

Flat Washer: 1/4"

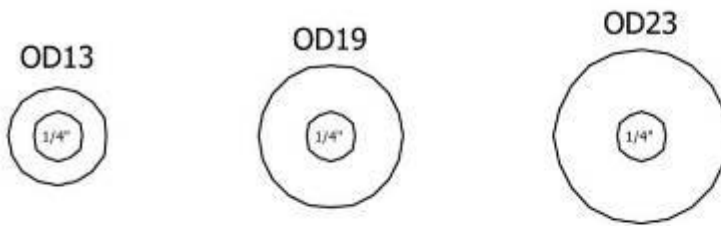

Flat Washer: 5/16"

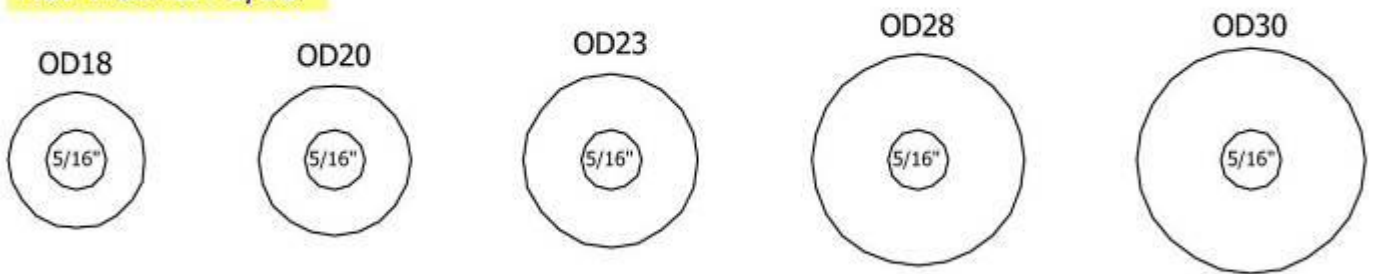

Flat Washer: 3/8"

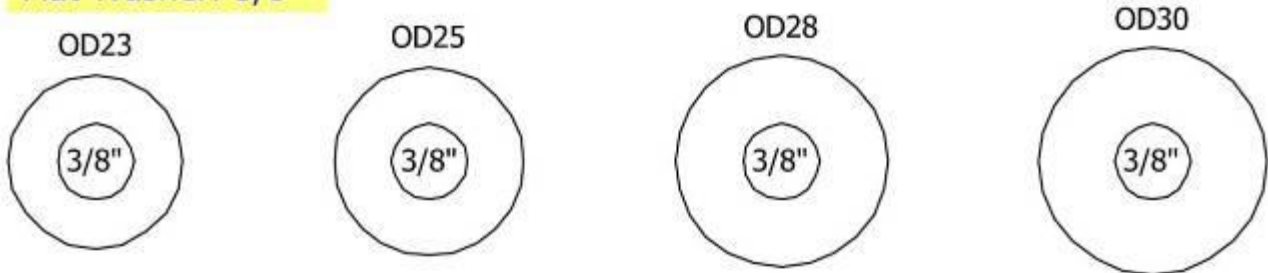

Flat Washer: 1/2"

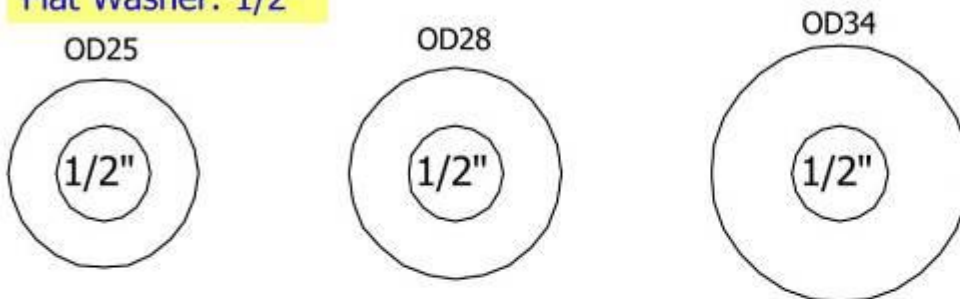

Flat Washer: 7/16"

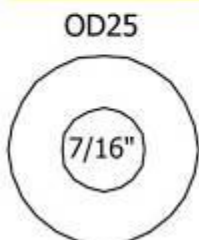

Flat Washer: 5/8"

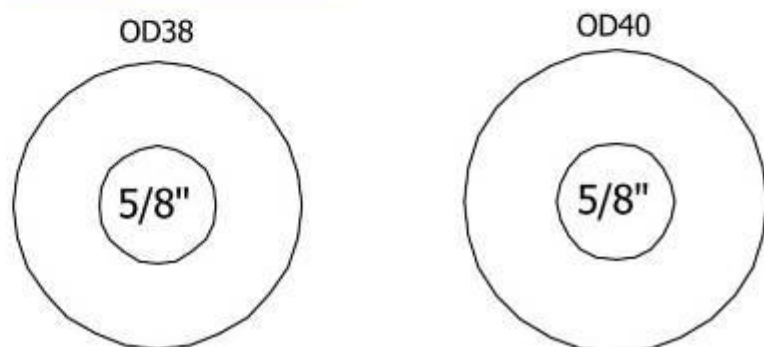

HEX NUT

3/16"



HEX NUT

1/4"



HEX NUT

5/16"

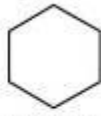

HEX NUT

3/8"



HEX NUT

1/2"

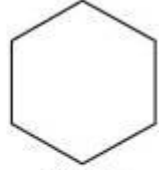

HEX NUT

NYLON HEX NUT

1/4"



NYLON HEX NUT

5/16"



NYLON HEX NUT

3/8"



NYLON HEX NUT

1/2"



NYLON HEX NUT