

ITEM 1

| BILL OF MATERIALS | | | | | | | | | | |
|-------------------|----------------|-----------|-----|--------|--------------|--------------|-----------------------------------|-----------|------------------------|--|
| ITEM | DRAWING NUMBER | COMPONENT | QTY | QTY UM | WT. EA. (KG) | WT. EA. (LB) | ITEM DESCRIPTION | ITEM TEXT | MATERIAL SPECIFICATION | |
| 1 | | | 1 | | | | HOOD PLATE, 1/8" AL | | | |
| 2 | | | 2 | | | | 3"x3"x1/4" AL ANGLE, 50" LG | | | |
| 3 | | | 2 | | | | 2"x2"x1/8" AL SQ TUBE, 54" LG | | | |
| 4 | | | 2 | | | | 2"x2"x1/8" AL SQ TUBE, 31.25" LG | | | |
| 5 | | | 2 | | | | 2"x2"x1/8" AL SQ TUBE, 25.625" LG | | | |
| 6 | | | 2 | | | | 2"x2"x1/8" AL CHANNEL, 48" LG | | | |
| 7 | | | 4 | | | | SLIDER CARRIAGE | | | |
| 8 | | | 1 | | | | SLIDE TRACK 32.5" LG | | | |
| 9 | | | 1 | | | | 90° DUCT SECTION W/ FLANGE | | | |
| 10 | | | 2 | | | | 2"x2"x1/8" AL SQ TUBE, 41" LG | | | |
| 11 | | | 2 | | | | 3"x3"x1/4" AL ANGLE, 25.5" LG | | | |

NOTE: ONLY WEIGHTS OF MAJOR COMPONENTS ARE LISTED

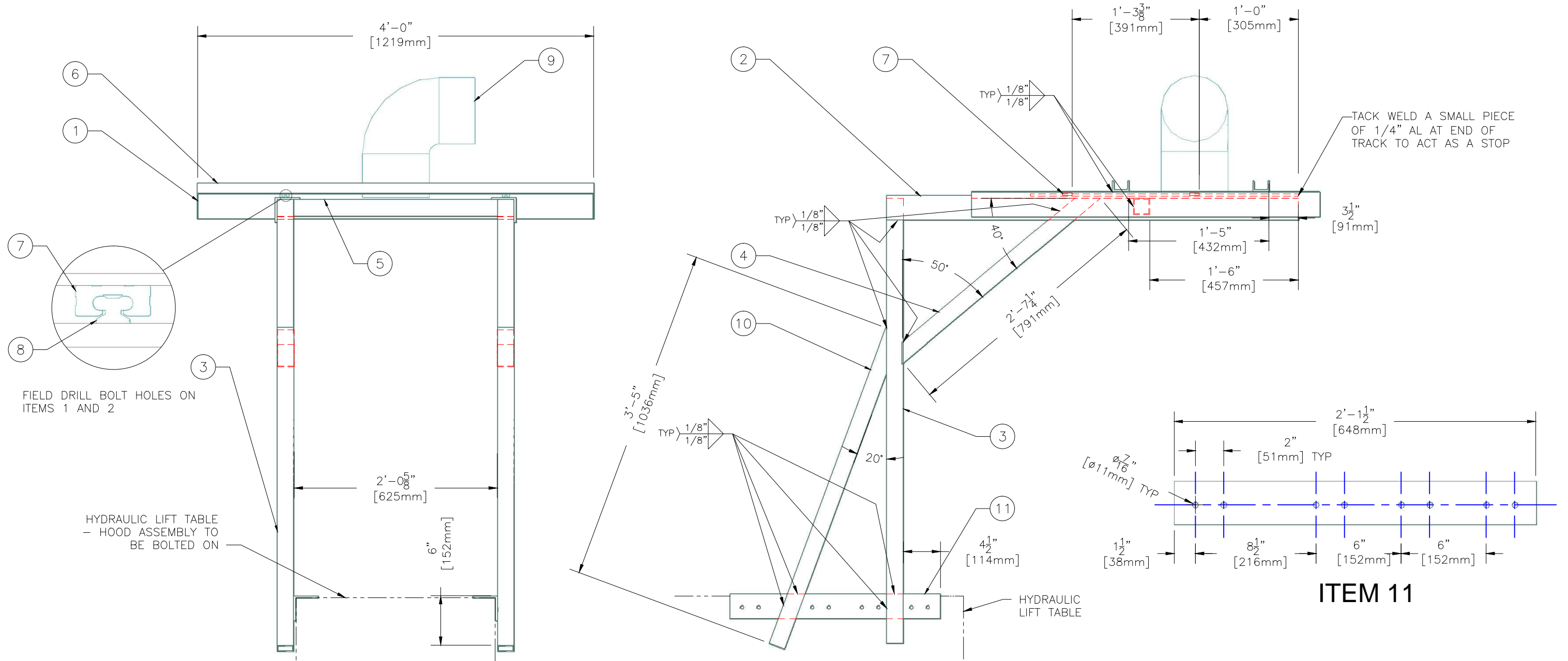

ITEM 11

| | | | | | | | | | | | | | | | | | |
|---|--------|--|------|----|-----------------|----------|-----|--|--|---|---|----------|--------------|------------|------------------|-----------|--------------|
| <p>CONFIDENTIAL</p> <p>THIS DRAWING IS THE PROPERTY OF AIR PRODUCTS AND CHEMICALS, INC. AND MUST BE ACCOUNTED FOR AND RETURNED TO THE COMPANY. INFORMATION HEREON IS CONFIDENTIAL AND MUST NOT BE USED, COPIED, REPRODUCED, DUPLICATED, DISCLOSED TO OTHERS IN WHOLE OR IN PART, OR SENT OUTSIDE THE COMPANY WITHOUT PROPER AUTHORIZATION.</p> | | <p>TOLERANCES UNLESS OTHERWISE SPECIFIED</p> <p>LINEAR ±1/16" (1.5mm)</p> <p>ANGLE ±0.5°</p> <p>HOLE LOCATION ±1/32" (1mm)</p> <p>HOLE SIZE ±1/32" (1mm)</p> | | 0 | INITIAL RELEASE | 07/08/15 | AJT | | | <p>AIR PRODUCTS</p> <p>Air Products and Chemicals, Inc. Wilkes Barre, Pennsylvania</p> | <p>TITLE: LONG SEAM WELD HOOD CONCEPT</p> | USED ON: | OWNER GROUP: | REFERENCE: | DOC. NO. T-01433 | SCALE: NA | SHEET 1 OF 1 |
| REV | CN NO. | REVISION DESCRIPTION | DATE | BY | CHK'D | APP'D | | | | | | | | | | | |