

Performance Contractors Duct Layout

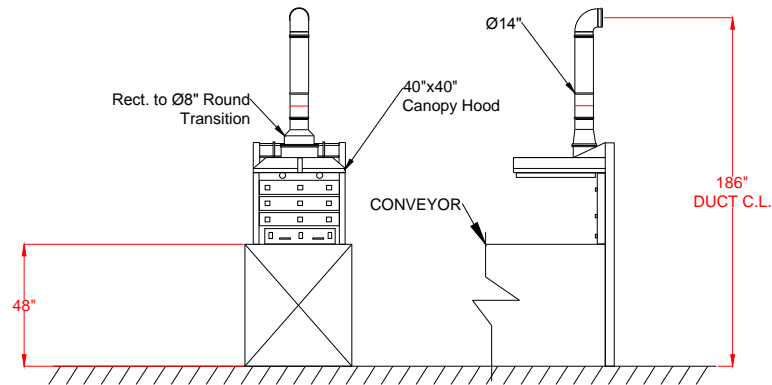

Front Side
Elevation Back-draft Canopy Hoods
(scale 2 to 1 for clarity)

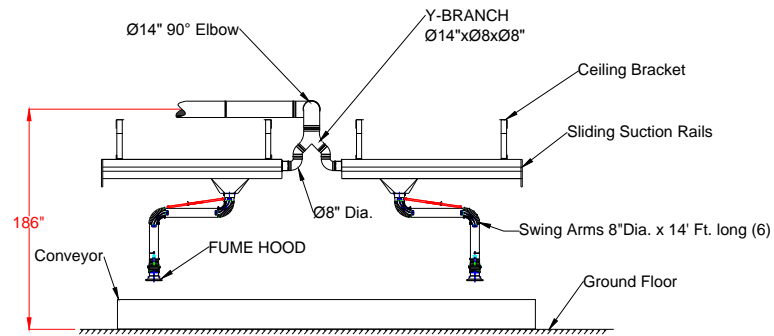

Elevation View Trolley Rail

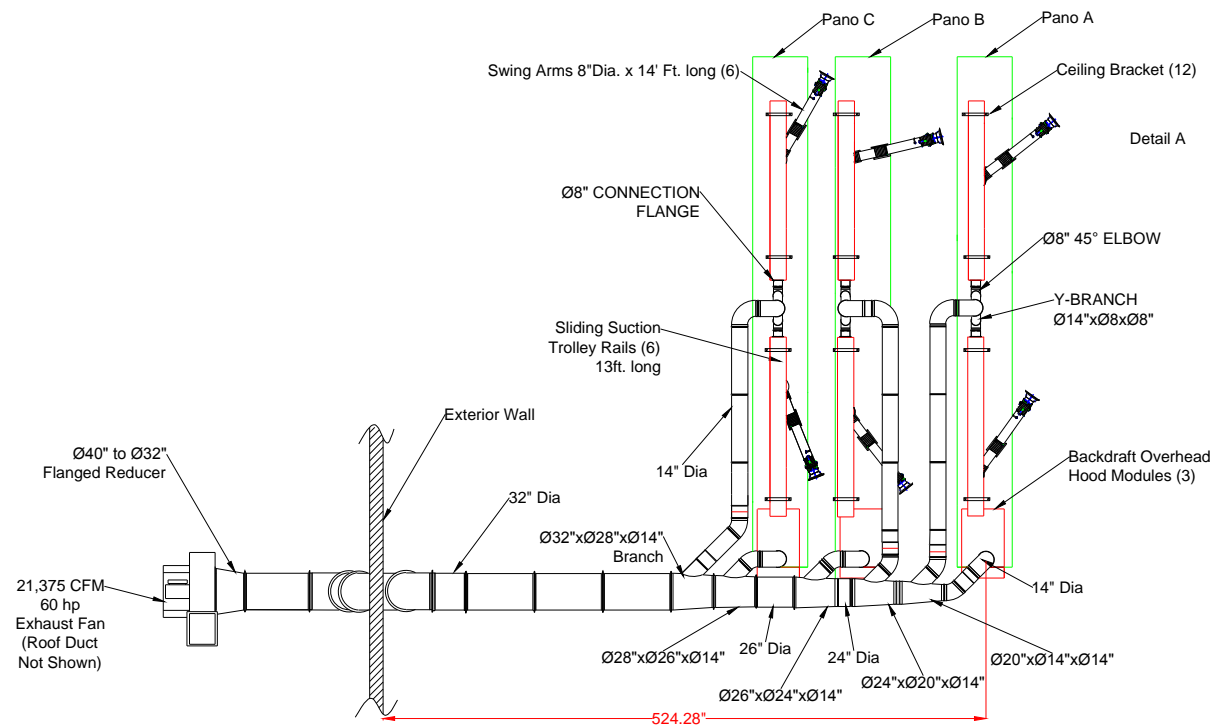

Plan View

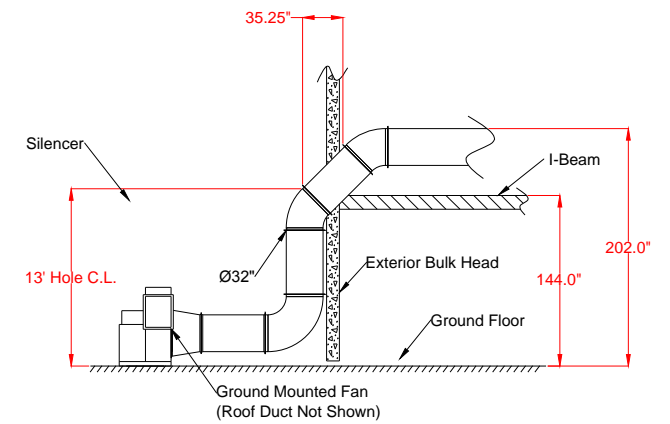

Elevation View Main Trunk Line

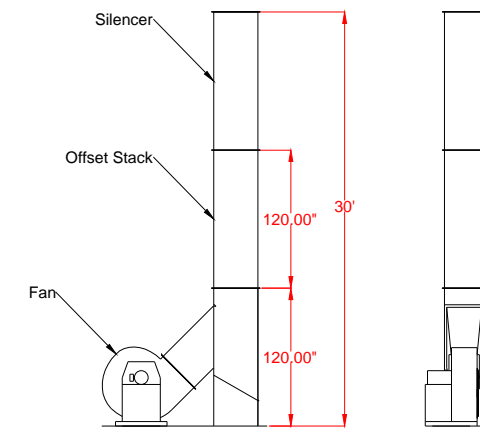

Elevation View Offset Stack

Avani Environmental Intl.
95 Cypress Drive
Youngsville, NC 27596
P# 919-570-2862 F# 919-570-2863

Avani

Project: Performance Contractors	
Drawing: Duct Layout	
Date: 2/11/2013	Drawn by: J.T.L
Sheet No: 1 of 1	Rev.: 1 Scale: Full