

DO NOT SCALE

IF IN DOUBT ASK

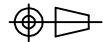

Revisions			
Rev	Description	Date	Approved

- SBU 1.5- SPECIFICATION -

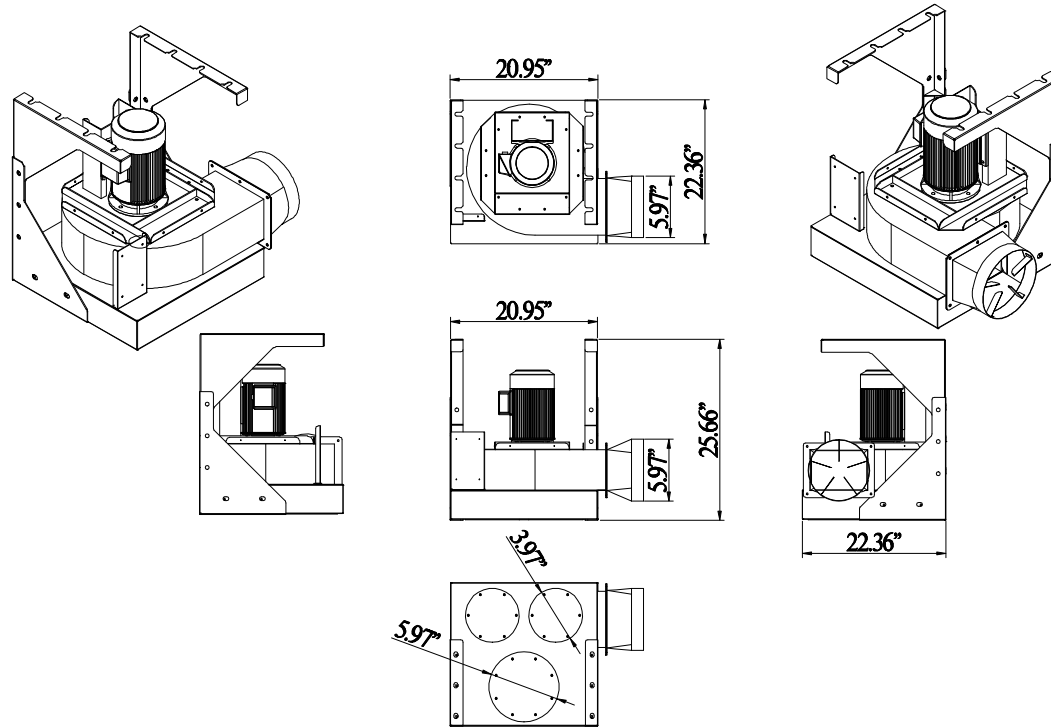

- Direct Drive Blower
- Motor: 1.5HP x 1 pc
- 575 Volt, 3Phase, 60HZ
- CFM: 886 ft³/min
- Arm Port Size: dia. 6" x 1 hole
dia. 4" x 2 holes
- Construction: 14 Gauge Steel Cabinet
- Packing Size (L x W x H):
24" x 23" x 22"
- N.W.: 125 lbs

Includes:

- Manual Control Box with Starter/Overload
- standard wall-mounting brackets

OPTIONS

***optional ceiling-mounting brackets

AVANI ENVIRONMENTAL INTL. INC. Sales Department
 95 Cypress Drive
 Youngsville, NC 27596

(919) 570-2862
 info@avanienvironmental.com

	Date	Name	Part Number:	Title:
Drawn by:	2012-02-03	DOJ	SBU-1.5	Blower SBU-1.5
Checked by:				
The drawings, AutoCAD, 3-D Models, and specifications are the property of Avani Environmental Intl. Inc. (AE) and may not be reproduced, distributed, modified, or otherwise used, except provided herein, without the express written permission of AE.				Drawing Number:

Size	Scale
A	1 = 1