

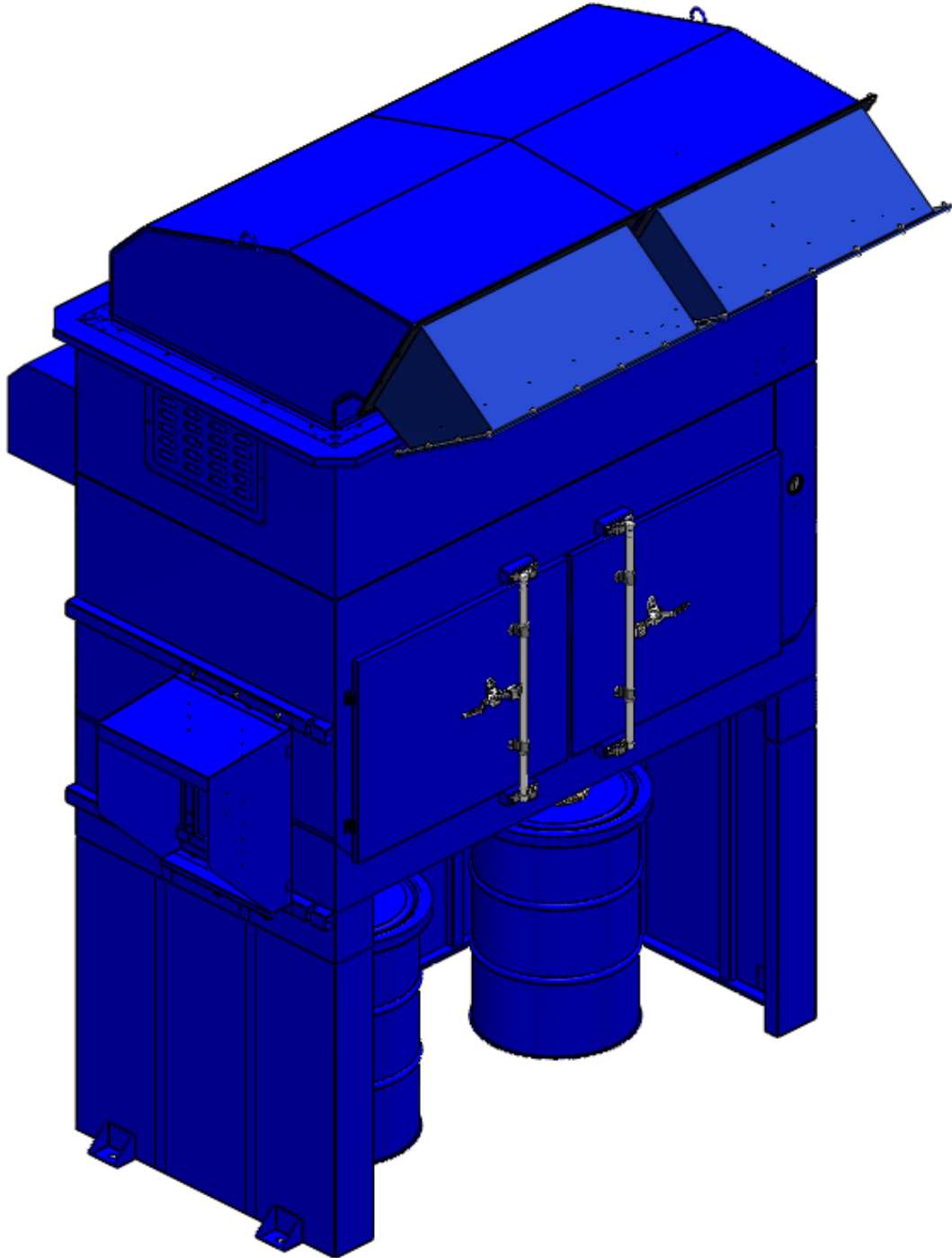

✦ Installations for the unit for SDC-15D-12.

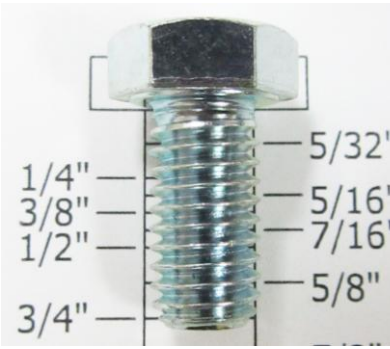

✦ Installations for the unit for SDC-15D-12.

- Take out the number : **LS** and **KS-1**
- Put **LS** on the left side of **KS-1** when facing the unit.
- Join **LS** and **KS-1** together with :

Hardware 6				
Part name	Description	Photo	Q'ty	Grainger Model #
Hex Screw	3/8" x 1"		6	1YU43
Flat Washer	3/8" x OD23 x 2T		12	*1JY33
Hex Nut	3/8"		6	2FE57

(*) Hardware item at similar spec available locally.

✦ Installations for the unit for SDC-15D-12.

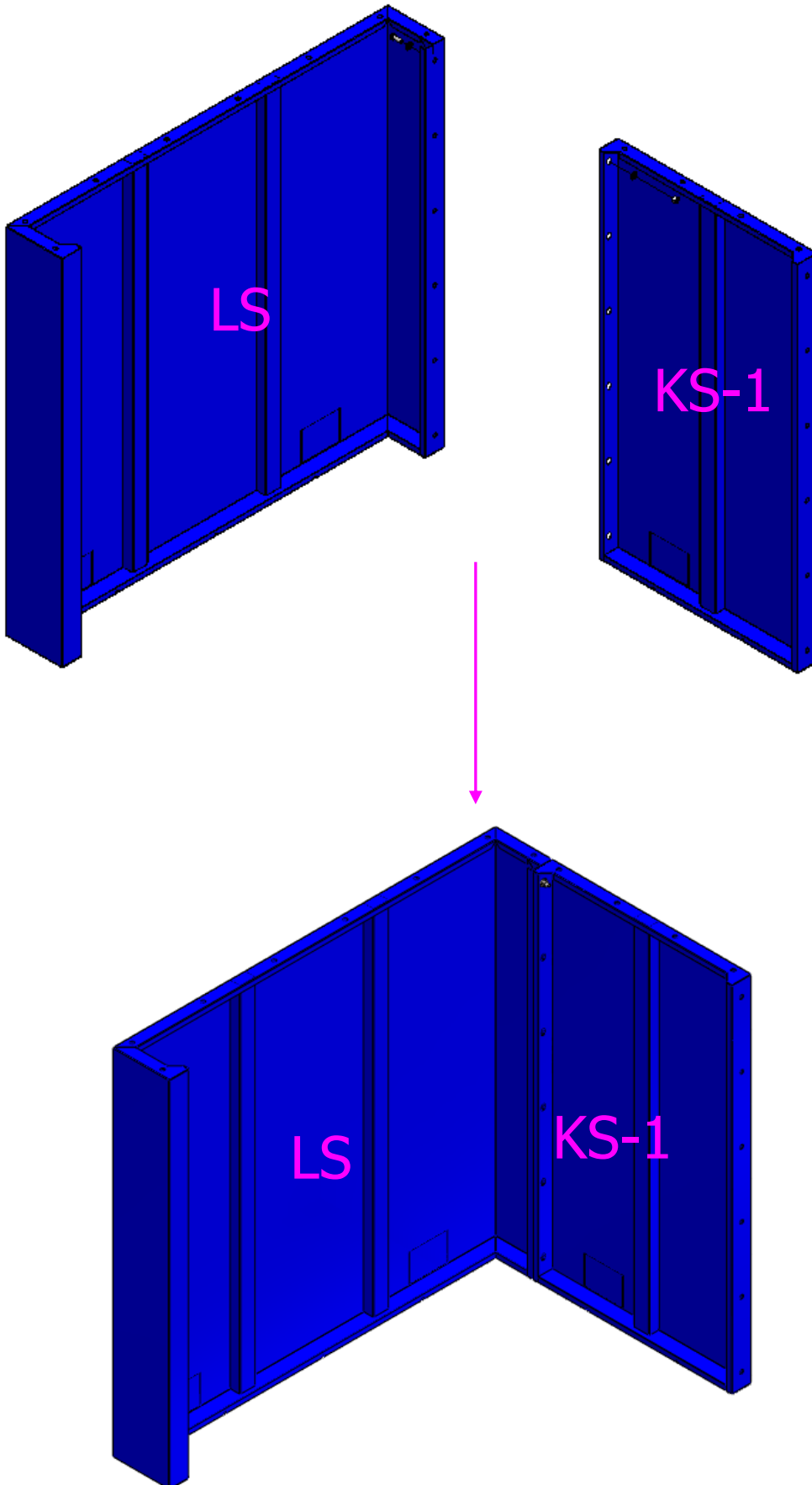

✦ Installations for the unit for SDC-15D-12.

- Take out the number : **KS-2**
- Put **KS-2** on the right side of **KS-1** when facing the unit.
- Fasten **KS-2** to **KS-1** with :

Hardware 5				
Part name	Description	Photo	Q'ty	Grainger Model #
Hex Screw	3/8" x 1"		6	1YU43
Flat Washer	3/8" x OD23 x 2T		12	*1JY33
Hex Nut	3/8"		6	2FE57

(*) Hardware item at similar spec available locally.

✦ Installations for the unit for SDC-15D-12.

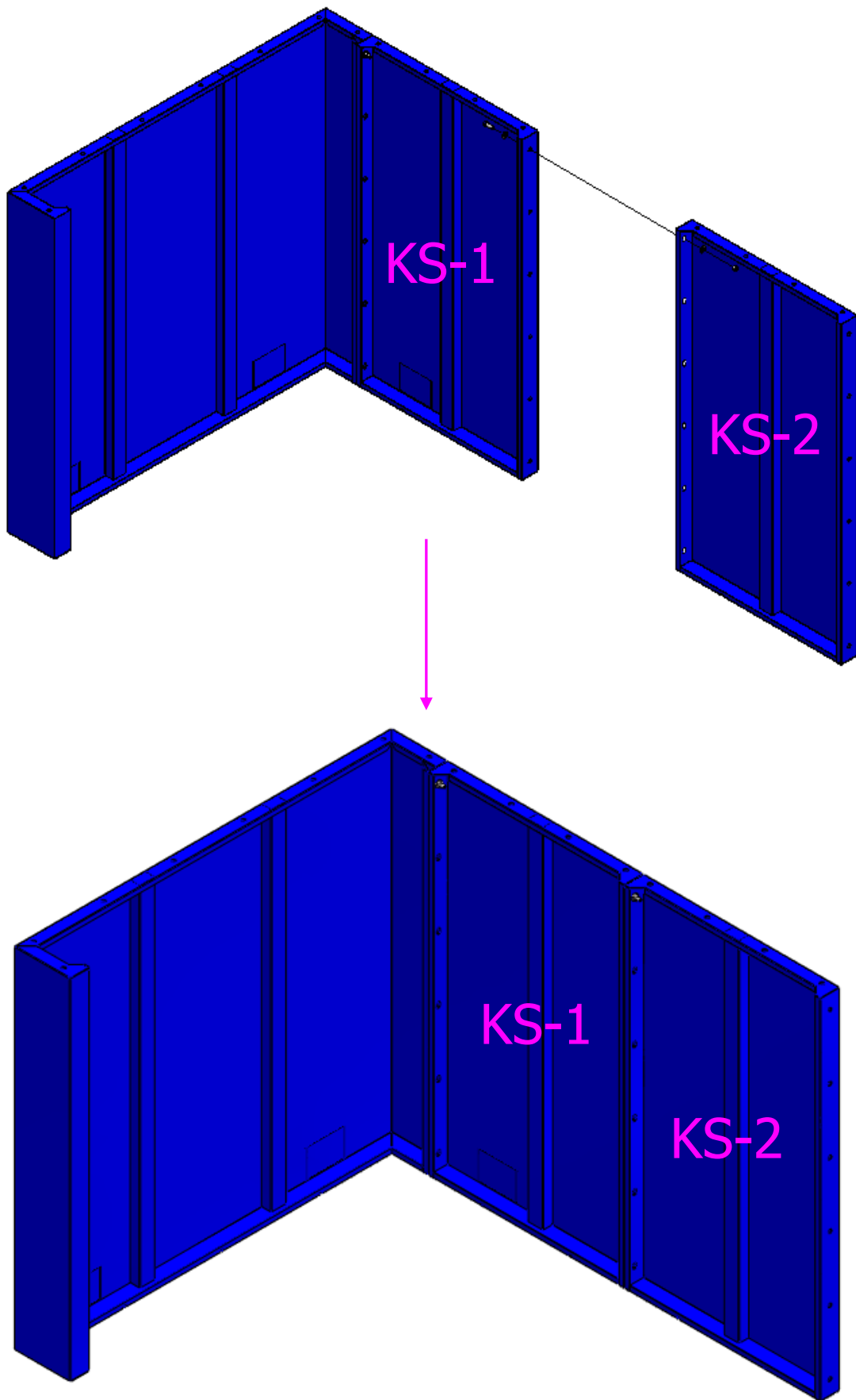

✚ Installations for the unit for SDC-15D-12.

- Take out the number : **KS-3**
- Put **KS-3** on the right side of **KS-2** when facing the unit.
- Fasten **KS-3** to **KS-2** with :

Hardware 5				
Part name	Description	Photo	Q'ty	Grainger Model #
Hex Screw	3/8" x 1"		6	1YU43
Flat Washer	3/8" x OD23 x 2T		12	*1JY33
Hex Nut	3/8"		6	2FE57

(*) Hardware item at similar spec available locally.

✦ Installations for the unit for SDC-15D-12.

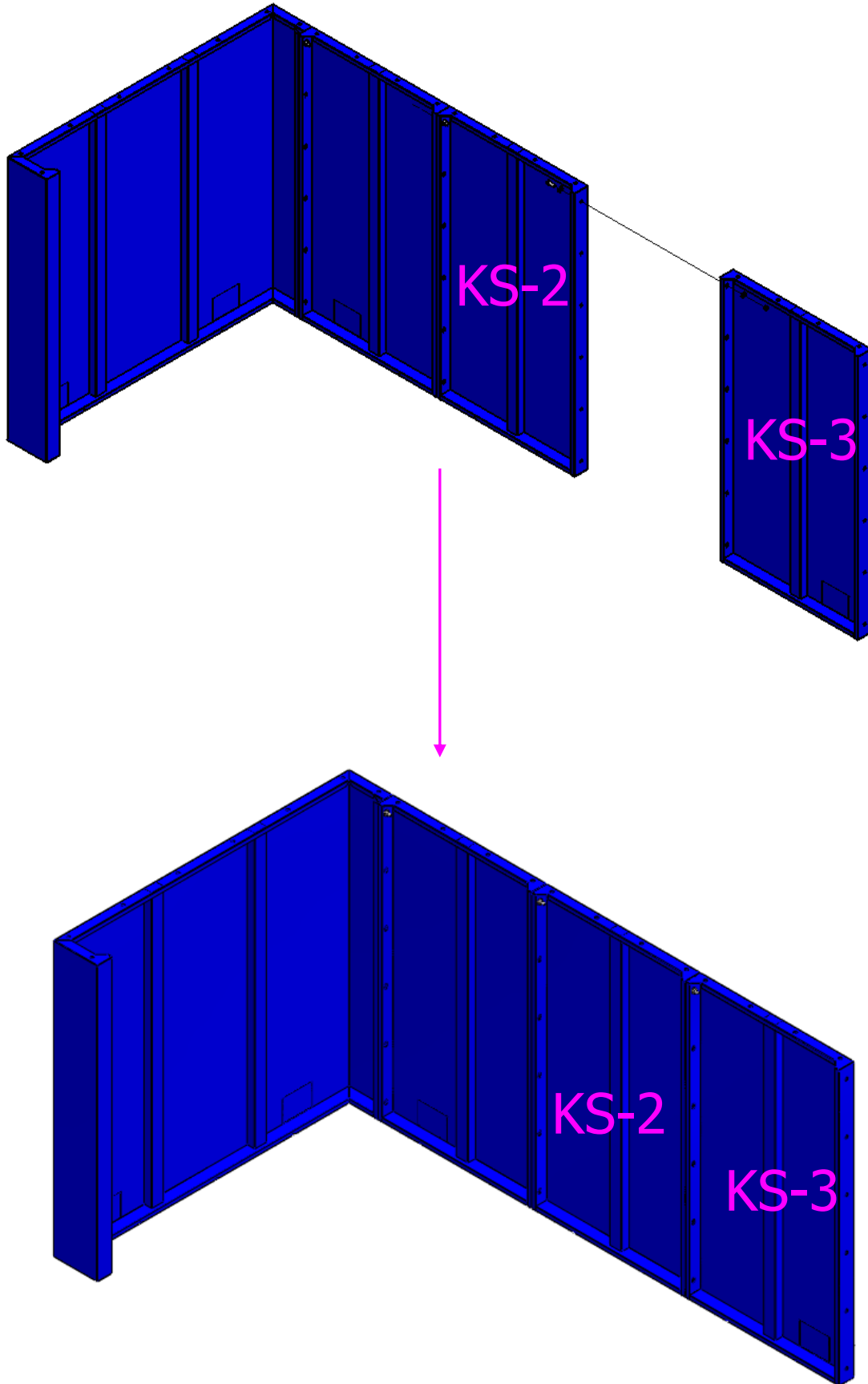

✦ Installations for the unit for SDC-15D-12.

- Take out the number : **RS**
- Put **RS** on the left side of **KS-3** when facing the unit.
- Fasten **KS-3** to **RS** with :

Hardware 6				
Part name	Description	Photo	Q'ty	Grainger Model #
Hex Screw	3/8" x 1"		6	1YU43
Flat Washer	3/8" x OD23 x 2T		12	*1JY33
Hex Nut	3/8"		6	2FE57

(*) Hardware item at similar spec available locally.

✦ Installations for the unit for SDC-15D-12.

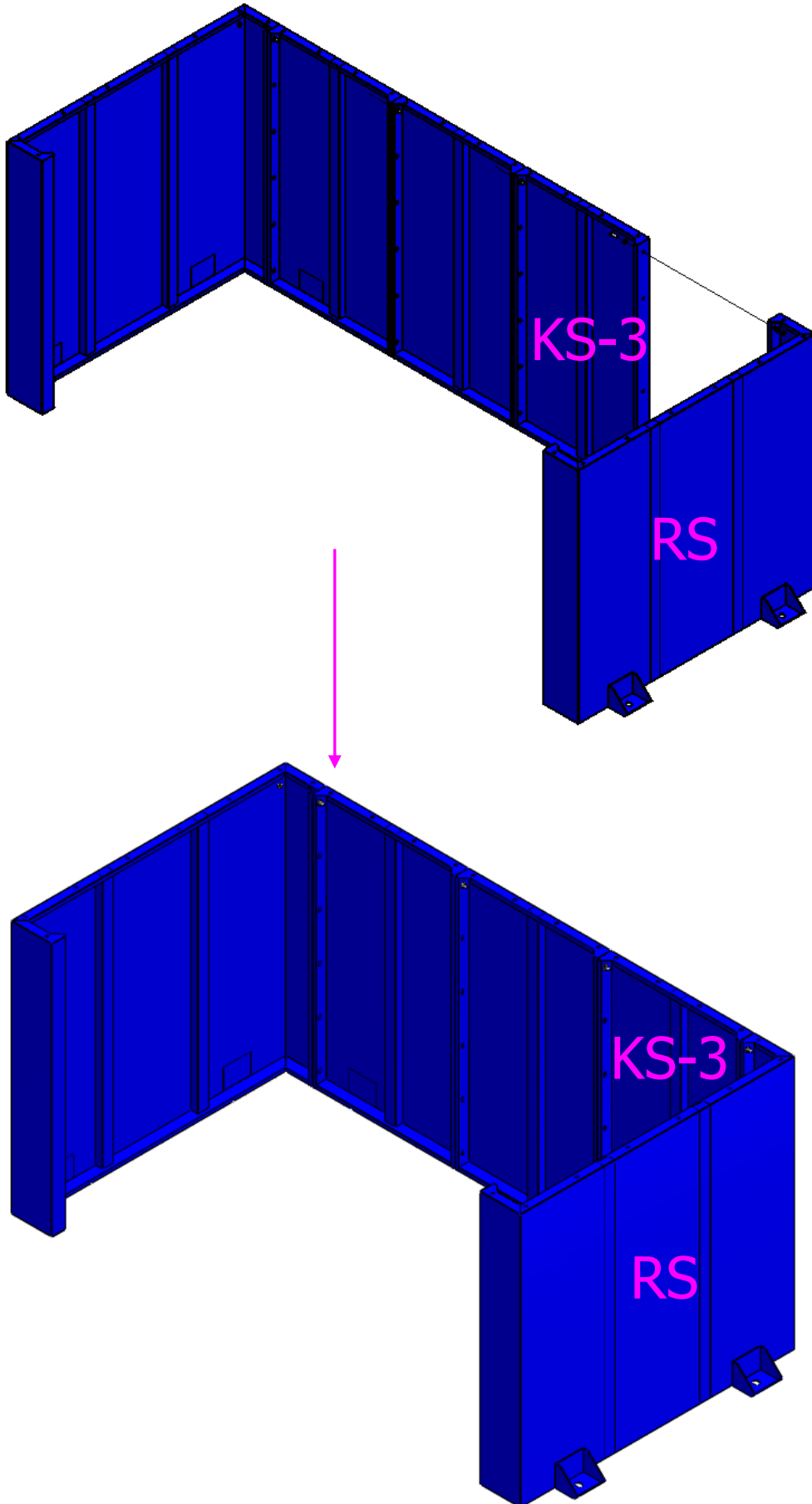

✚ Installations for the unit for SDC-15D-12.

- Take out the **Hopper**
- Fasten **Hopper** to the unit with :
-

Hardware 8

Part name	Description	Photo	Q'ty	Grainger Model #
Hex Screw	3/8" x 1"		40	1YU43
Flat Washer	3/8" x OD23 x 2T		80	*1JY33
Hex Nut	3/8"		40	2FE57

(*) Hardware item at similar spec available locally.

✦ Installations for the unit for SDC-15D-12.

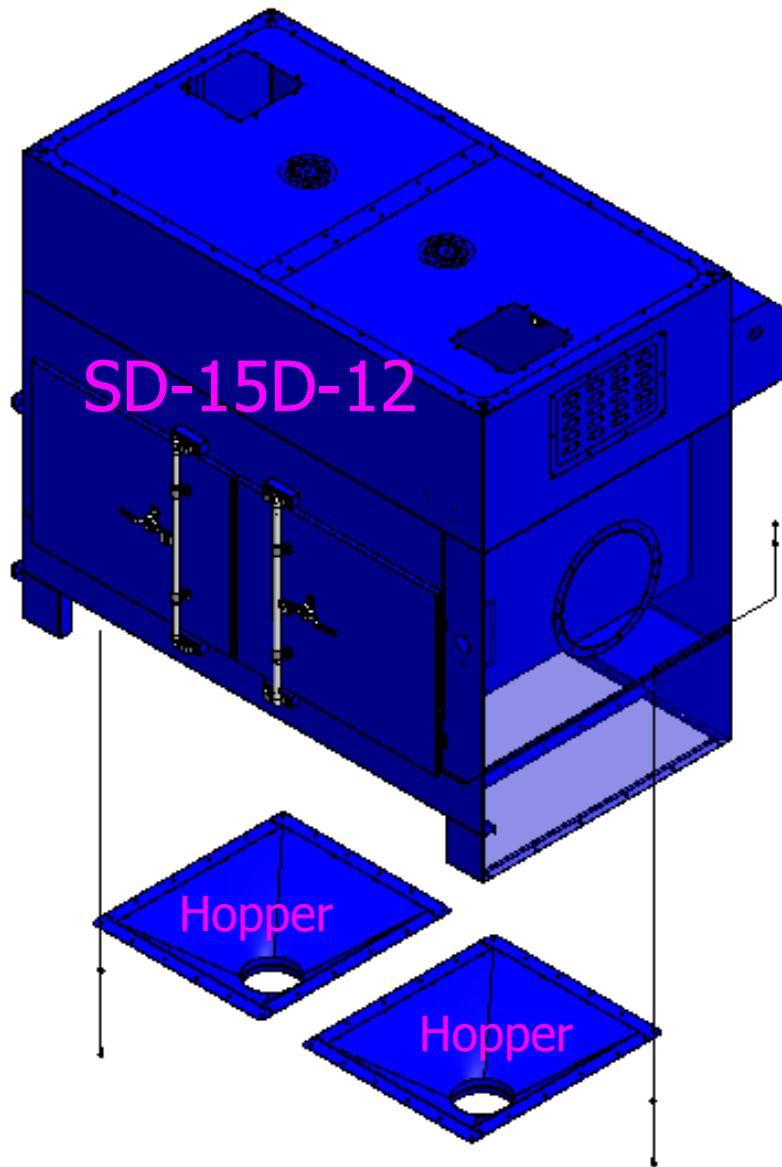

✚ Installations for the unit for SDC-15D-12.

- Take out the number : **BL-L** and **BL-R**
- Fasten **BL-L** and **BL-R** to **Outdoor Cover** with :

Hardware 3				
Part name	Description	Photo	Q'ty	Grainger Model #
Hex Screw	3/8" x 1"		32	1YU43
Flat Washer	3/8" x OD23 x 2T		64	*1JY33
Hex Nut	3/8"		32	2FE57

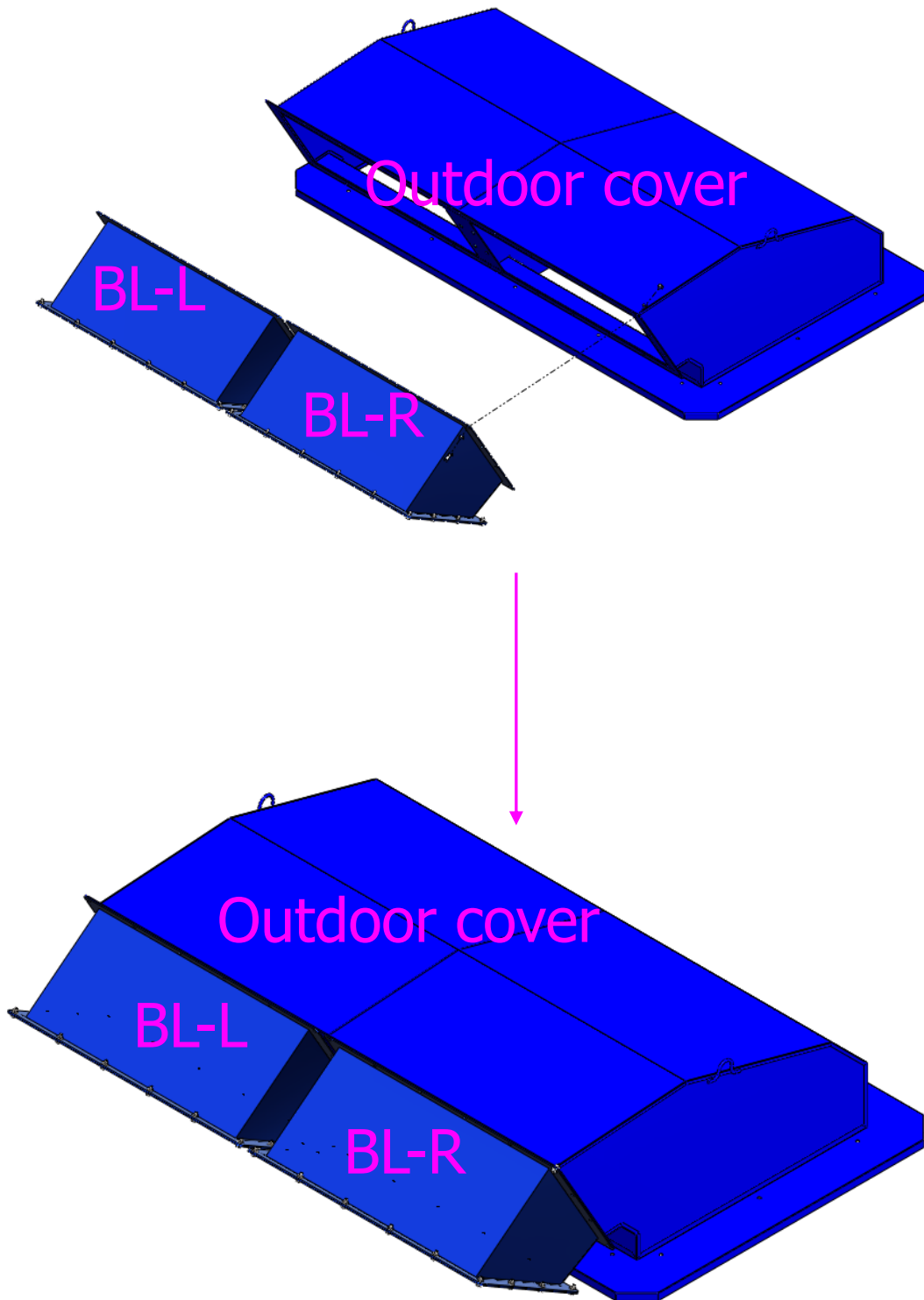

(*) Hardware item at similar spec available locally.

✦ Installations for the unit for SDC-15D-12.



✦ Installations for the unit for SDC-15D-12.

- Fasten **Outdoor Cover** to the unit with :

Hardware 4				
Part name	Description	Photo	Q'ty	Grainger Model #
Hex Screw	5/16" x 1-1/2"		16	1YU36
Rubber Washer	M8		16	*4PAH3

(*) Hardware item at similar spec available locally.

✦ Installations for the unit for SDC-15D-12.

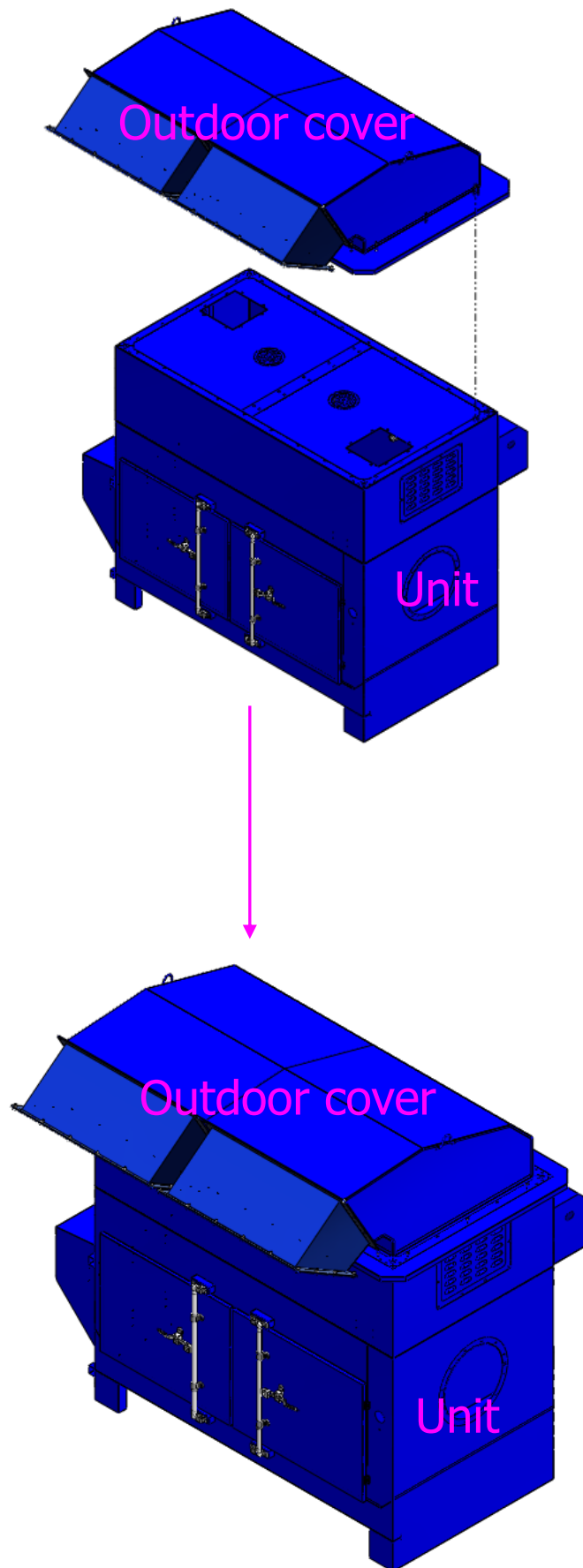

✚ Installations for the unit for SDC-15D-12.

- Fasten **LS**, **KS1~3** and **BS** to the unit with :

Hardware 7				
Part name	Description	Photo	Q'ty	Grainger Model #
Hex Screw	3/8" x 1"		28	1YU43
Flat Washer	3/8" x OD23 x 2T		56	*1JY33
Hex Nut	3/8"		28	2FE57

(*) Hardware item at similar spec available locally.

✦ Installations for the unit for SDC-15D-12.

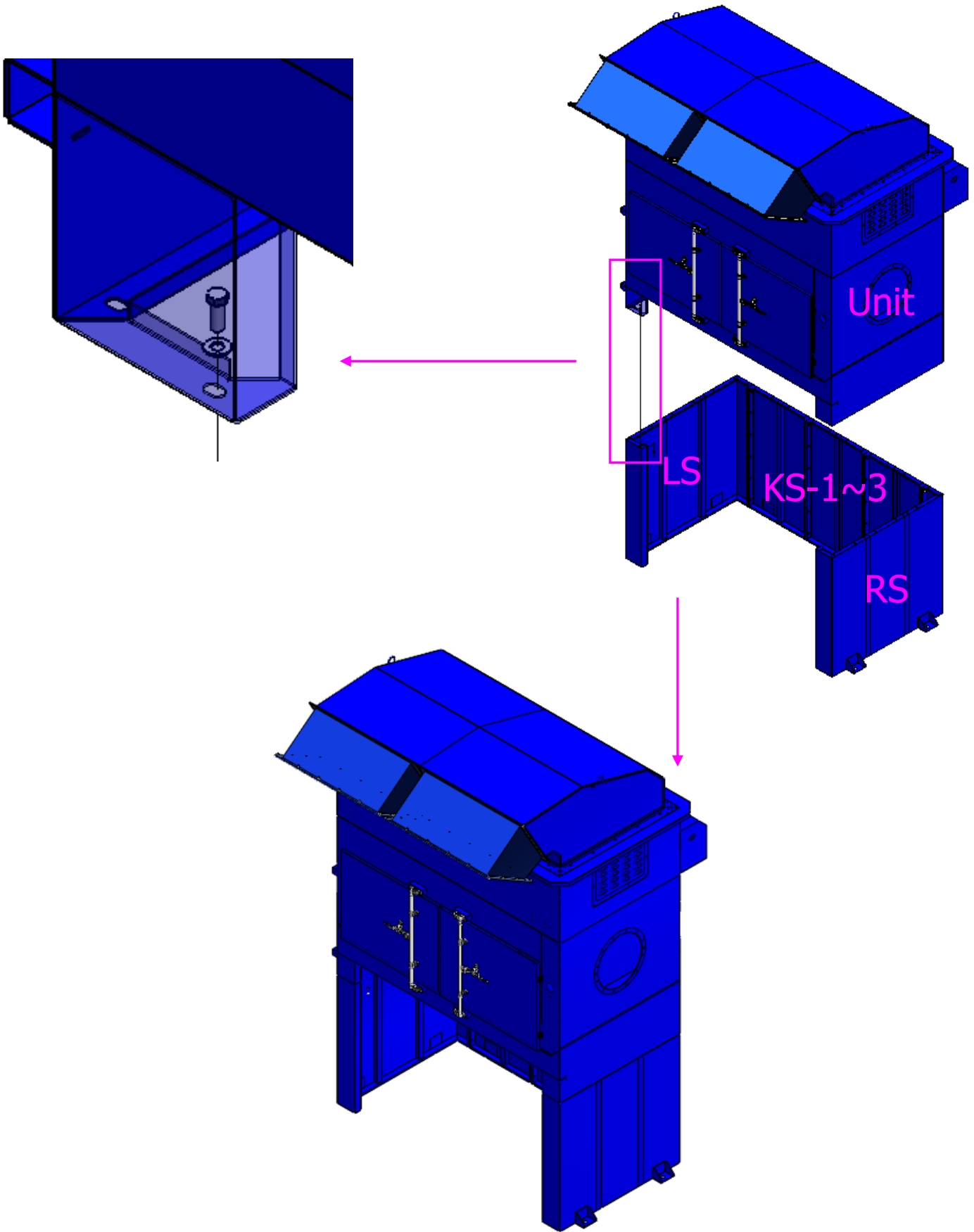

✦ Installations for the unit for SDC-15D-12.

- Fasten **hose** to the **hopper**.

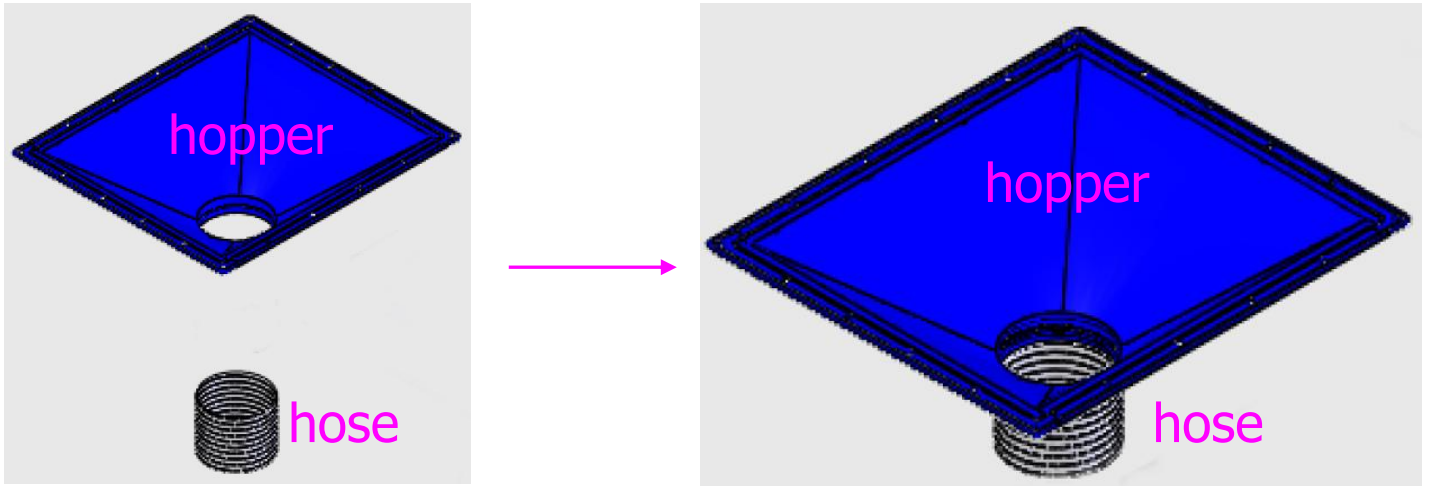

- Insert **hose** into **clamps** and fasten the clamp.

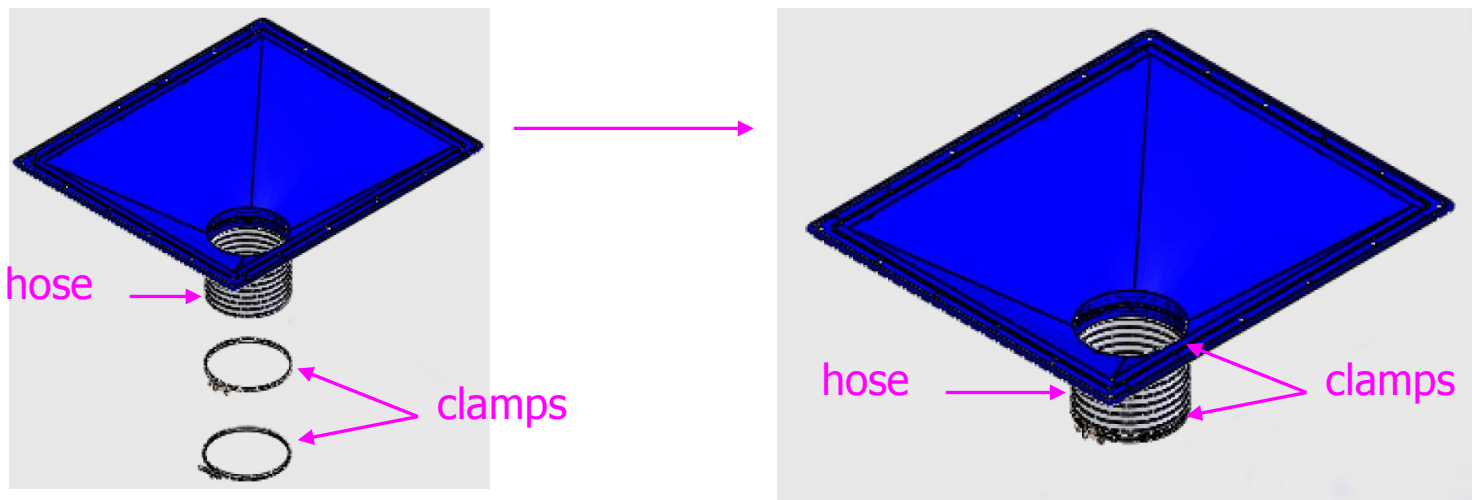

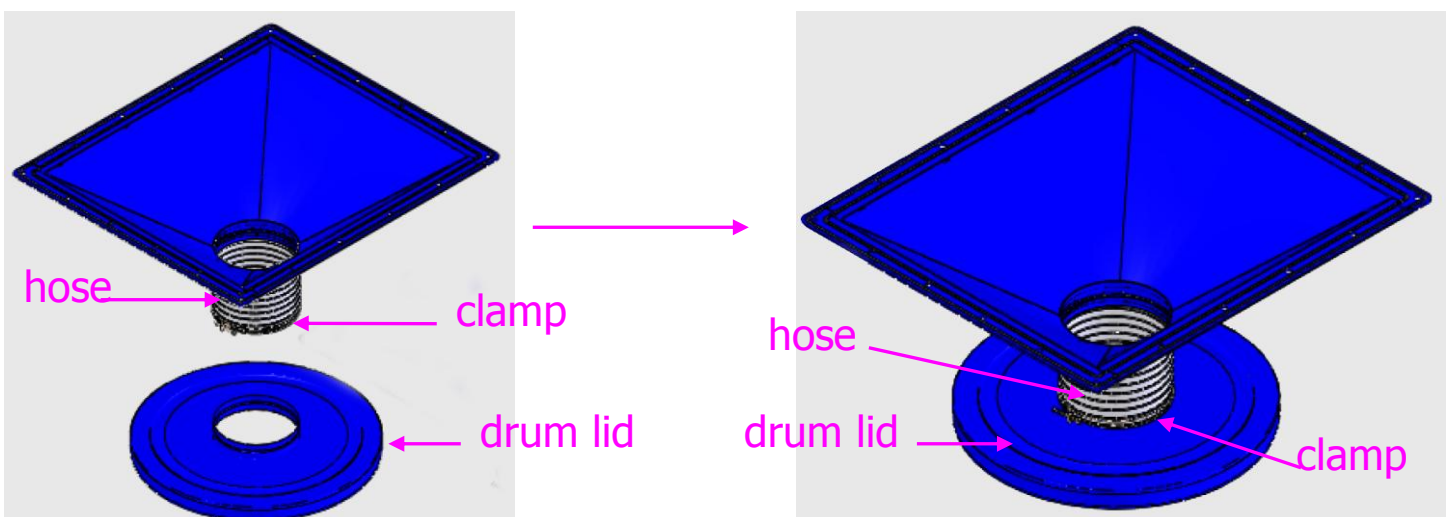

- Insert **drum Lid** into **hose** and fasten the clamp.

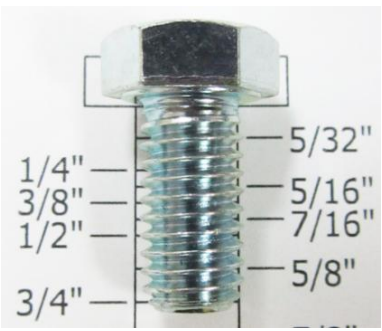

✦ Installations for the unit for SDC-15D-12.

- Fasten **the base of control box** to the unit with :

Hardware 2				
Part name	Description	Photo	Q'ty	Grainger Model #
Hex Screw	3/8" x 3/4"		6	1YU42
Flat Washer	3/8" x OD23 x 2T		6	*1JY33

✚ Installations for the unit for SDC-15D-12.

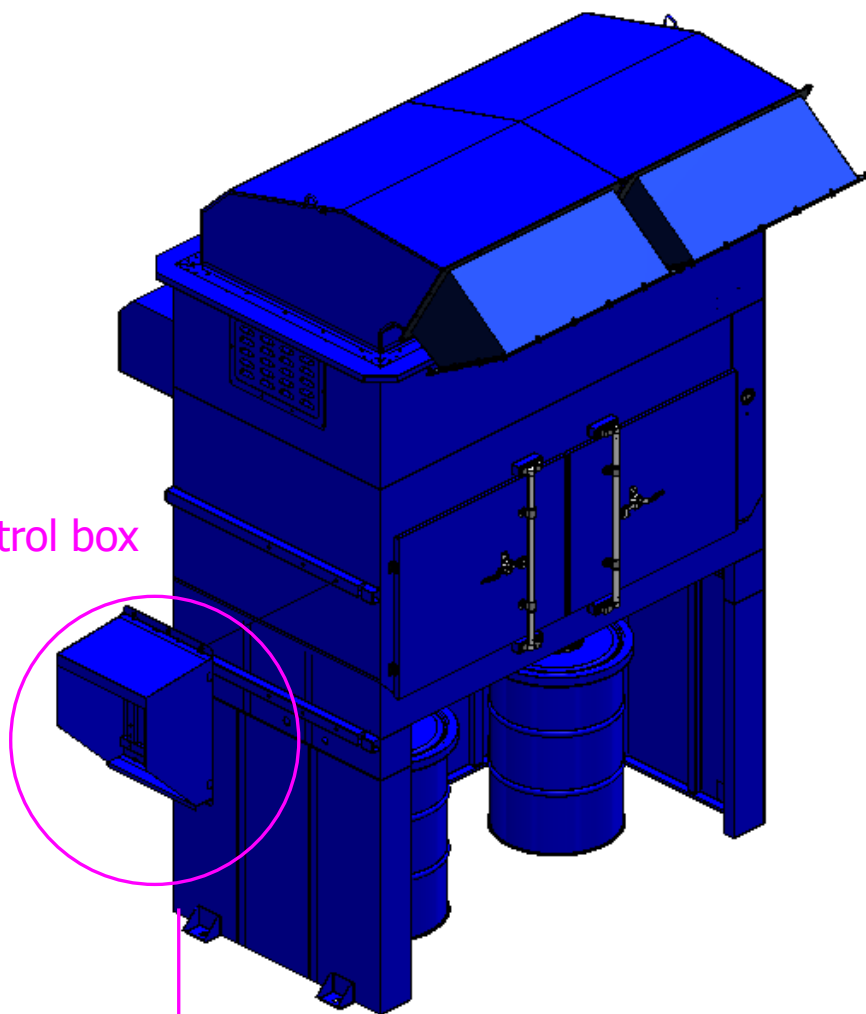

The base of control box

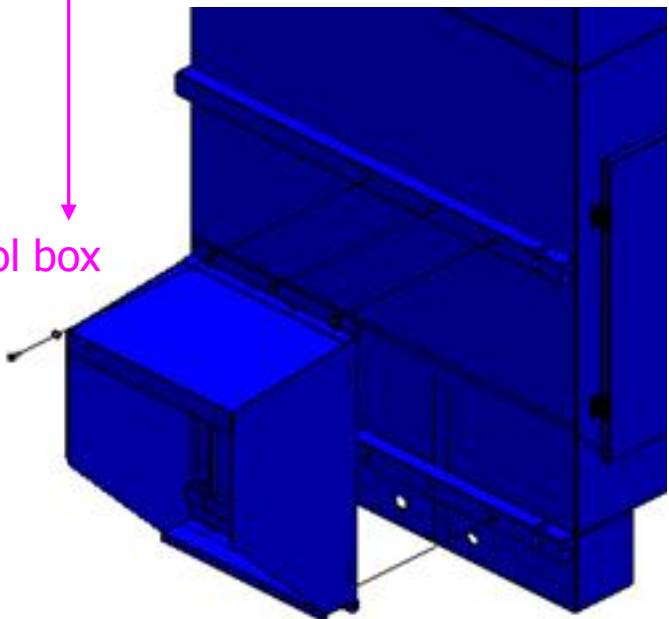

The base of control box

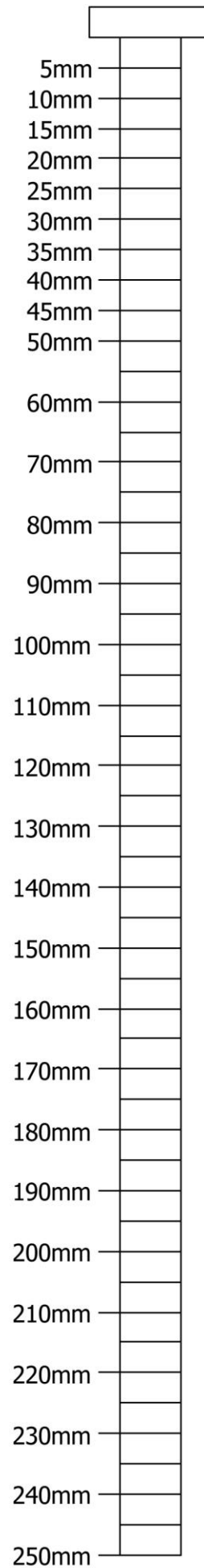
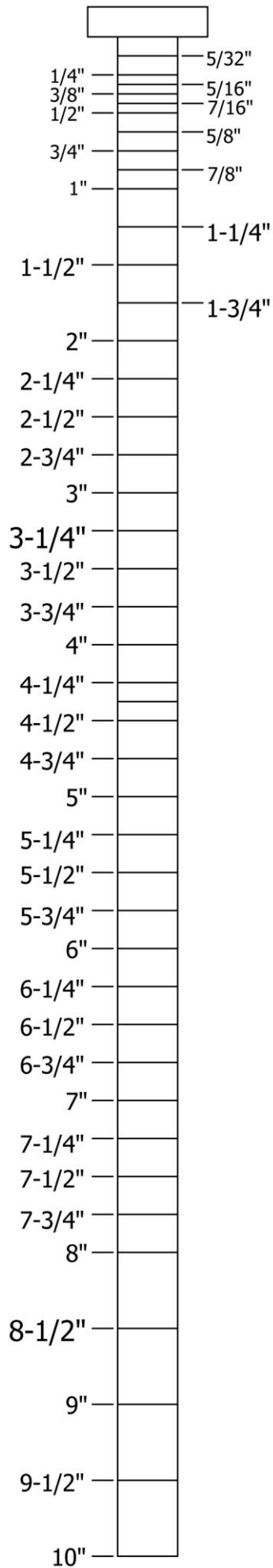

Flat Washer: 1/4"

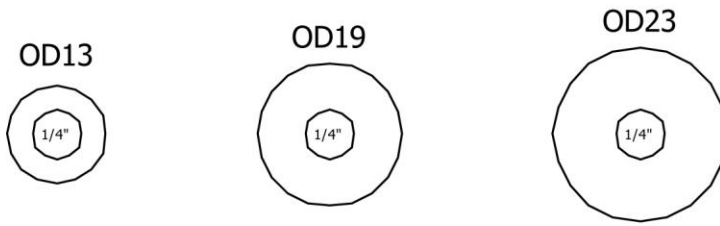

Flat Washer: 5/16"

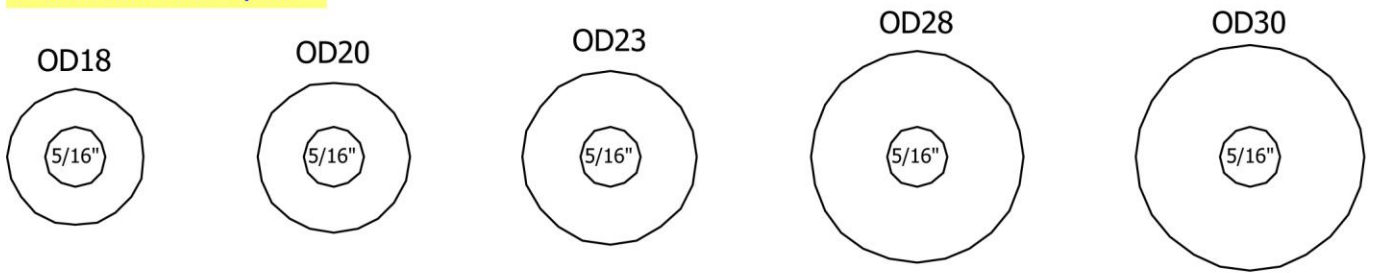

Flat Washer: 3/8"

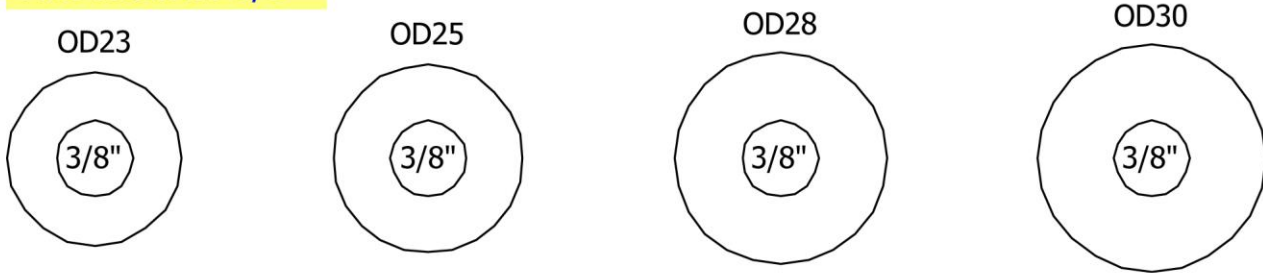

Flat Washer: 1/2"

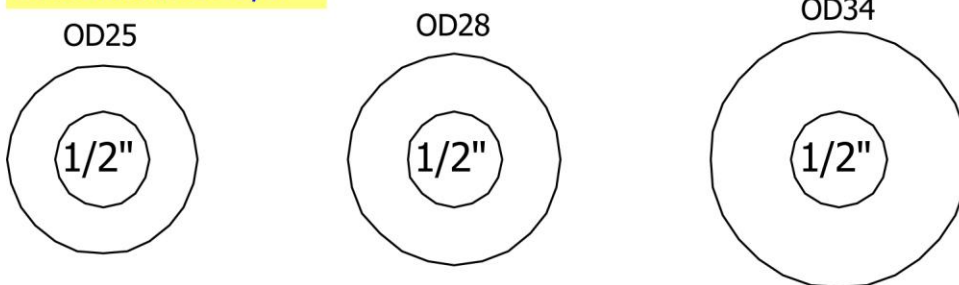

Flat Washer: 7/16"

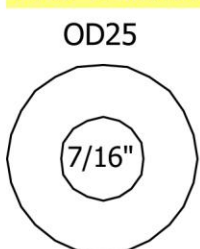

Flat Washer: 5/8"

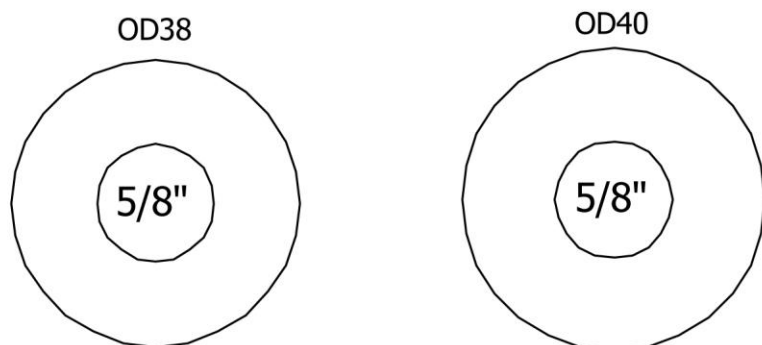

HEX NUT

3/16"



HEX NUT

1/4"



HEX NUT

5/16"



HEX NUT

3/8"



HEX NUT

1/2"

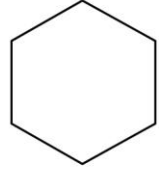

HEX NUT

NYLON HEX NUT

1/4"



NYLON HEX NUT

5/16"



NYLON HEX NUT

3/8"



NYLON HEX NUT

1/2"



NYLON HEX NUT

Rubber Washer

M8

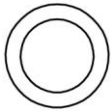

M12

