

DO NOT SCALE

IF IN DOUBT ASK

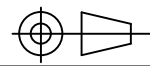

Johnson Controls w/ silencer

Revisions			
Rev	Description	Date	Approved

- SDC-10-8MD SPECIFICATION -

- Direct Drive Blower (on the machine top)
- Motor: 10HP x 1 pc
- CFM: 4,400 ft³/min @ 8" SP
- Include:
 - UL Individual Control Box for Cartridge Collector and Blower

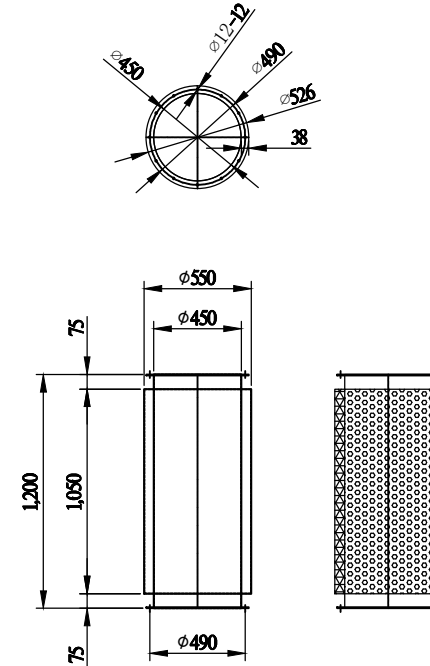
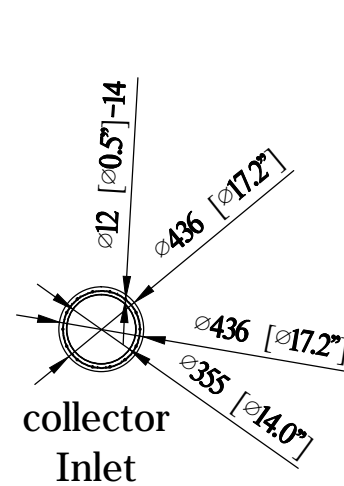
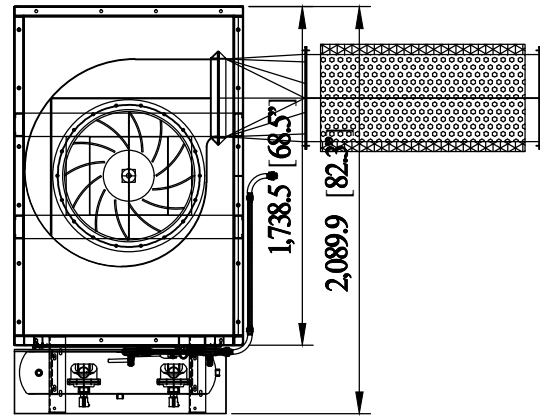

- *** Inlet: 14"
- Cartridge Filter: Dia. 325mm x 1320mm x 8pcs (Dia. 12.8" x 52" x 8pcs)
- Material: Polyester with TEFLON coating.
- Filter Area: 19m² x 8 = 152m² (1635.52 ft²)
- Pleat Depth: 48mm

- Horizontal Positioned Filters,
- Continuous Welded Seams,
- Gasket and Latched Doors,
- Powder Coated Paint and
- Reverse Jet Pulse Cleaning
- Include:

- Filter Chamber
- Inlet Square Pipe (need dimensions)

No. of Valves: 2

- Inlet Air: $\frac{3}{4}$ "
- Compressed Air Requirement: 90 PSI
- Compressed Air Reservoir: 7.9 gallon
- Dimension: 46.3" x 81.8" x 125.9" (1176 x 2075.5 x 3194.6mm)

Construction: 13 Gauge for panel;
11 Gauge Steel Cabinet

- Max. Operating Temp.: 120°C
- Paint Color: Blue

***w/ silencer.

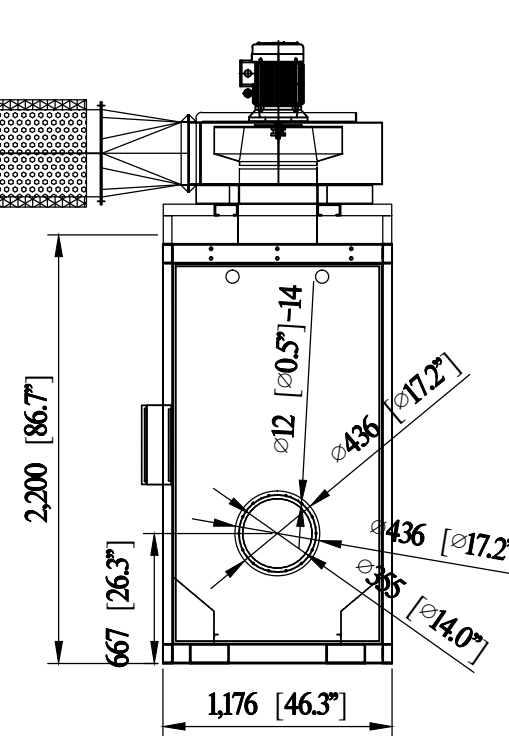
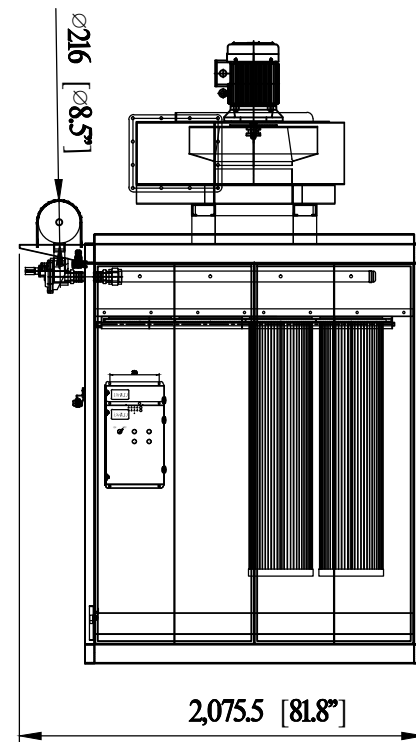
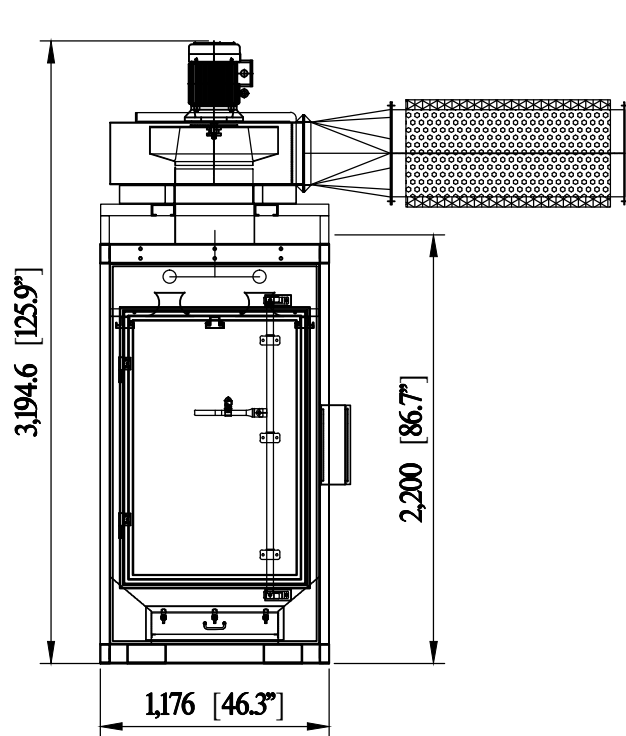

OSKAR -
AVANI ENVIRONMENTAL, INC.
95 Cypress Drive
Youngsville, NC 27596

Sales Department
(919) 570-2862
sales@oskarsales.com

Date	2010-09-20	Name	XXXXX	Part Number:	SDC-10-8MD	Title:	Cartridge Collector (mezzanine drawer type)
Drawn by:		Checked by:		This drawing is confidential and is the exclusive property of Oskar - Avani Environmental. No unauthorized use/copy or disclosure is to be made and it is returned whenever required.			

Size	Scale	Drawing Number:
A	1 = 1	SVL-800-01