

**+ Installations for SDT-1600.**

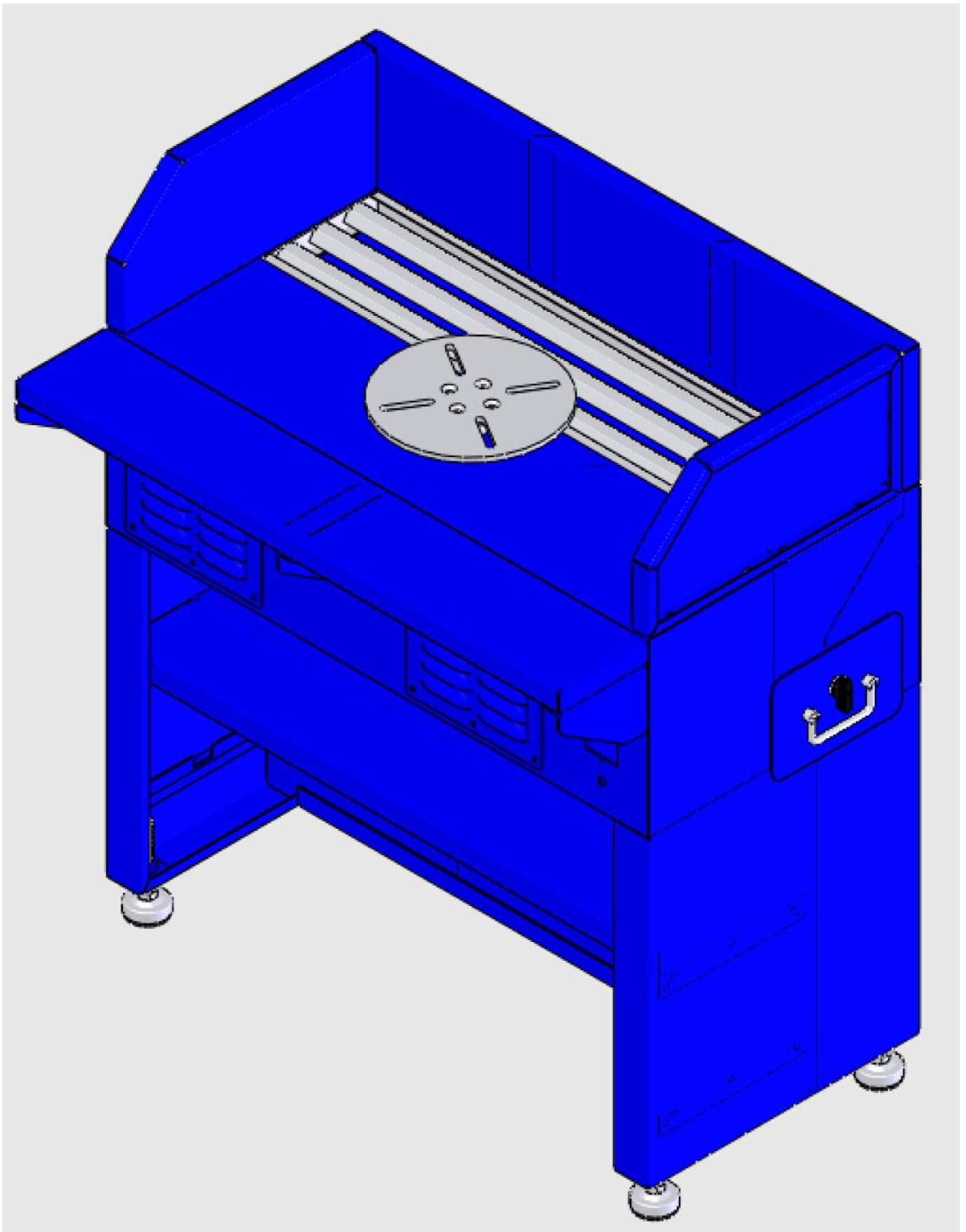

## ✚ Installations for SDT-1600.

- Take out the number: **CL**.
- Fasten **CL** to **SDT-1600** with:

Part name	Description	Photos	Q'ty	Grainger Model #
Hex Screw	5/16" x 3/4"		4	1YU33
Flat Washer	5/16" x OD23 x2T		4	*1JY31

(\* ) Hardware item at similar spec available locally.

## ✦ Installations for SDT-1600.

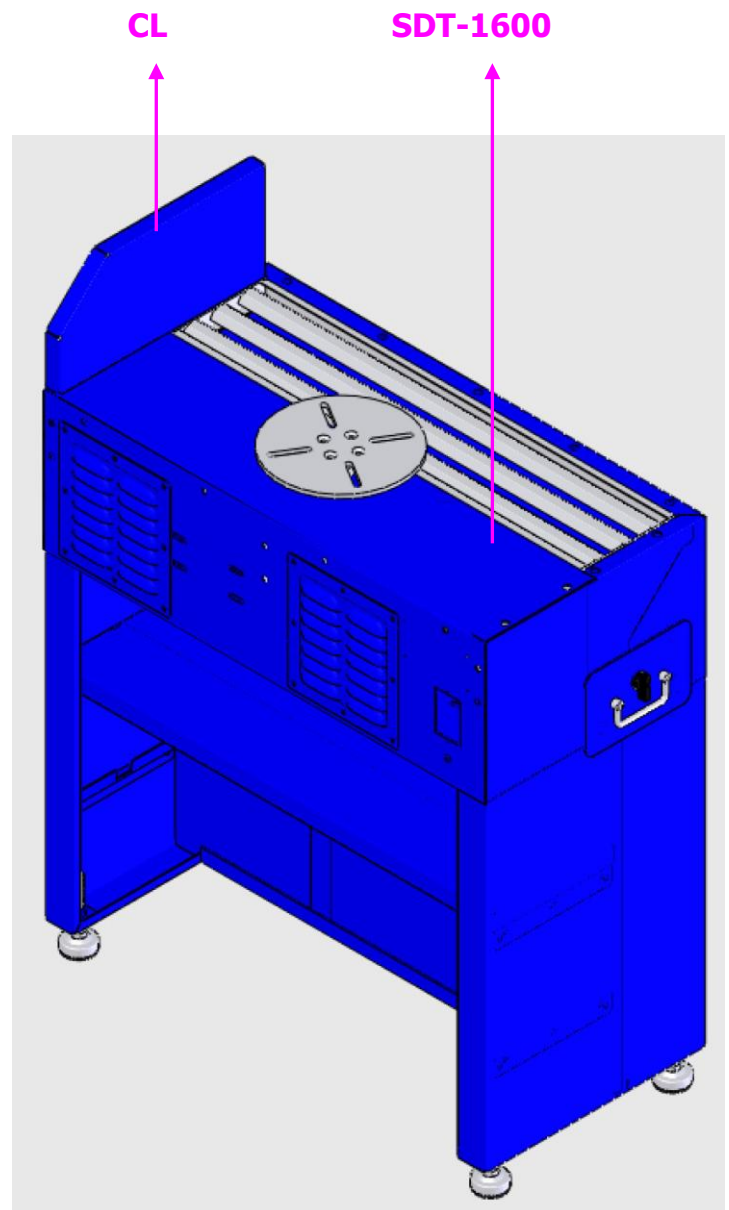
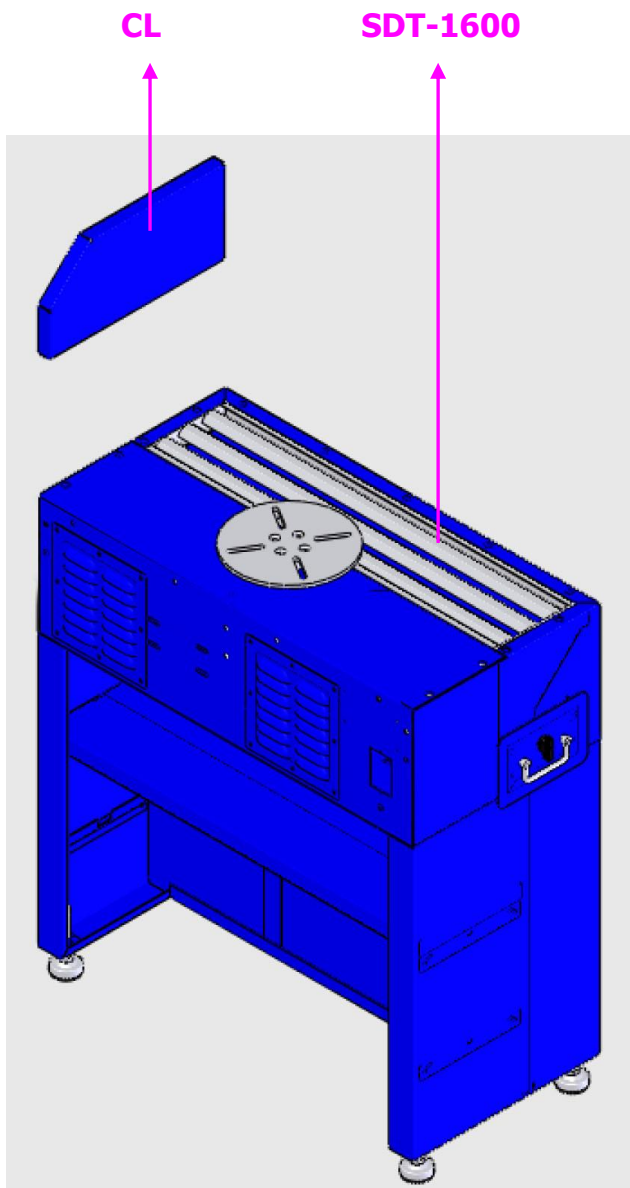

## ✚ Installations for SDT-1600.

- Take out the number: **CM**.
- Fasten **CM** to **SDT-1600** with:

Part name	Description	Photos	Q'ty	Grainger Model #
Hex Screw	5/16" x 3/4"		5	1YU33
Flat Washer	5/16" x OD23 x2T		5	*1JY31

(\* ) Hardware item at similar spec available locally.

## ✚ Installations for SDT-1600.

- Fasten **CM** to **CL** with:

Part name	Description	Photos	Q'ty	Grainger Model #
Hex Screw	5/16" x 3/4"		3	1YU33
Flat Washer	5/16" x OD23 x2T		6	*1JY31
Hex nut	5/16"		3	2FE51

**(\*) Hardware item at similar spec available locally.**

## ✚ Installations for SDT-1600.

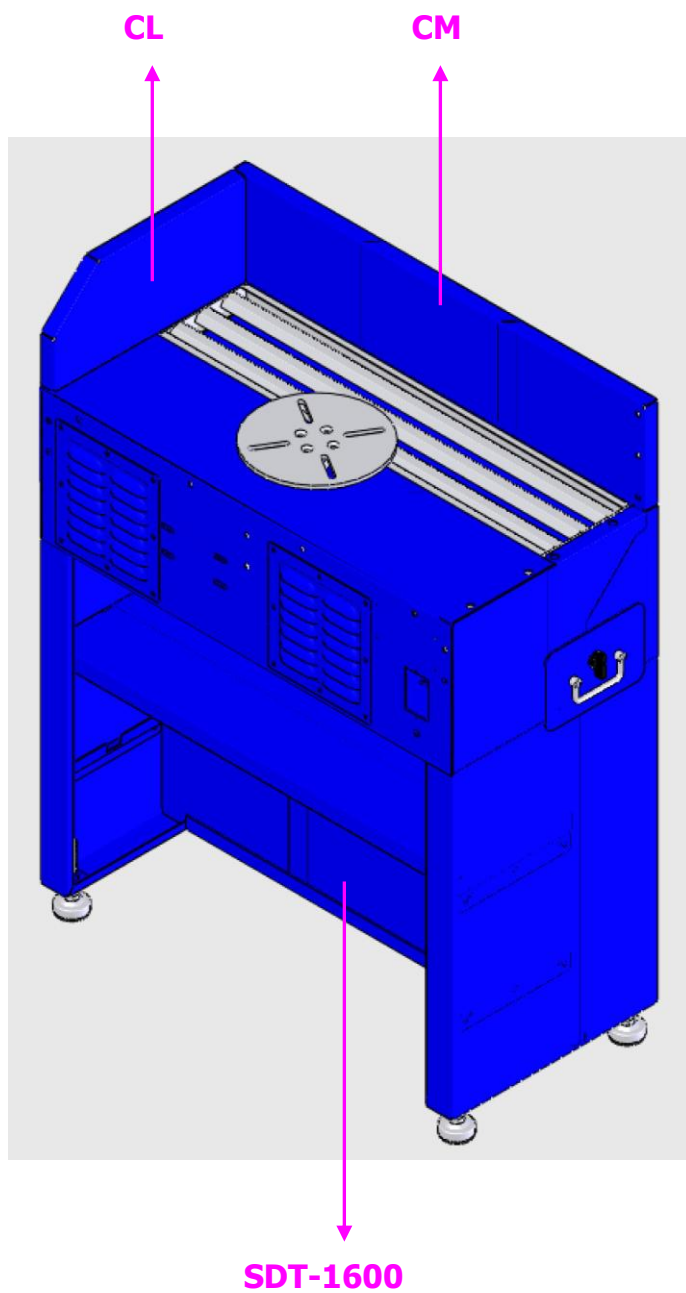
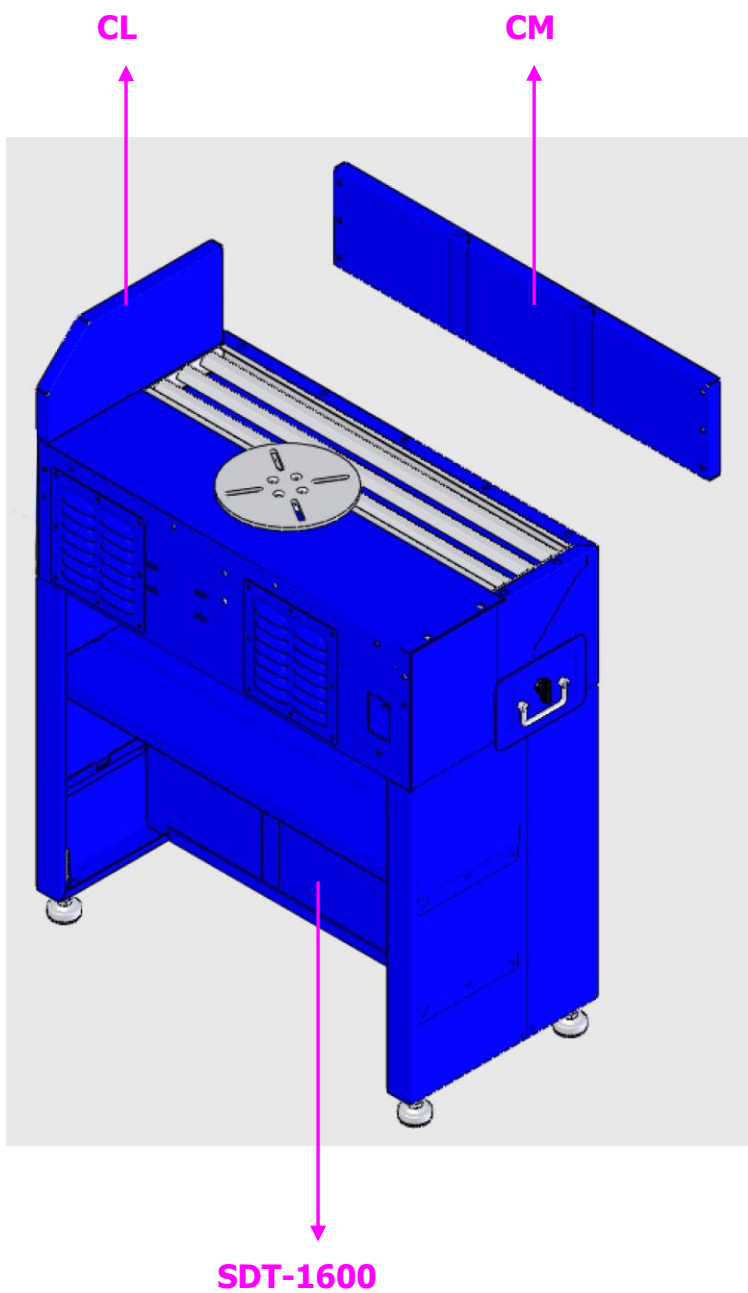



## ✚ Installations for SDT-1600.



- Take out the number: **CR**.
- Fasten **CR** to **SDT-1600** with:

Part name	Description	Photos	Q'ty	Grainger Model #
Hex Screw	5/16" x 3/4"		4	1YU33
Flat Washer	5/16" x OD23 x2T		4	*1JY31

(\* ) Hardware item at similar spec available locally.

## ✚ Installations for SDT-1600.

- Fasten **CR** to **CM** with:

Part name	Description	Photos	Q'ty	Grainger Model #
Hex Screw	5/16" x 3/4"		3	1YU33
Flat Washer	5/16" x OD23 x2T		6	*1JY31
Hex nut	5/16"		3	2FE51

**(\*) Hardware item at similar spec available locally.**



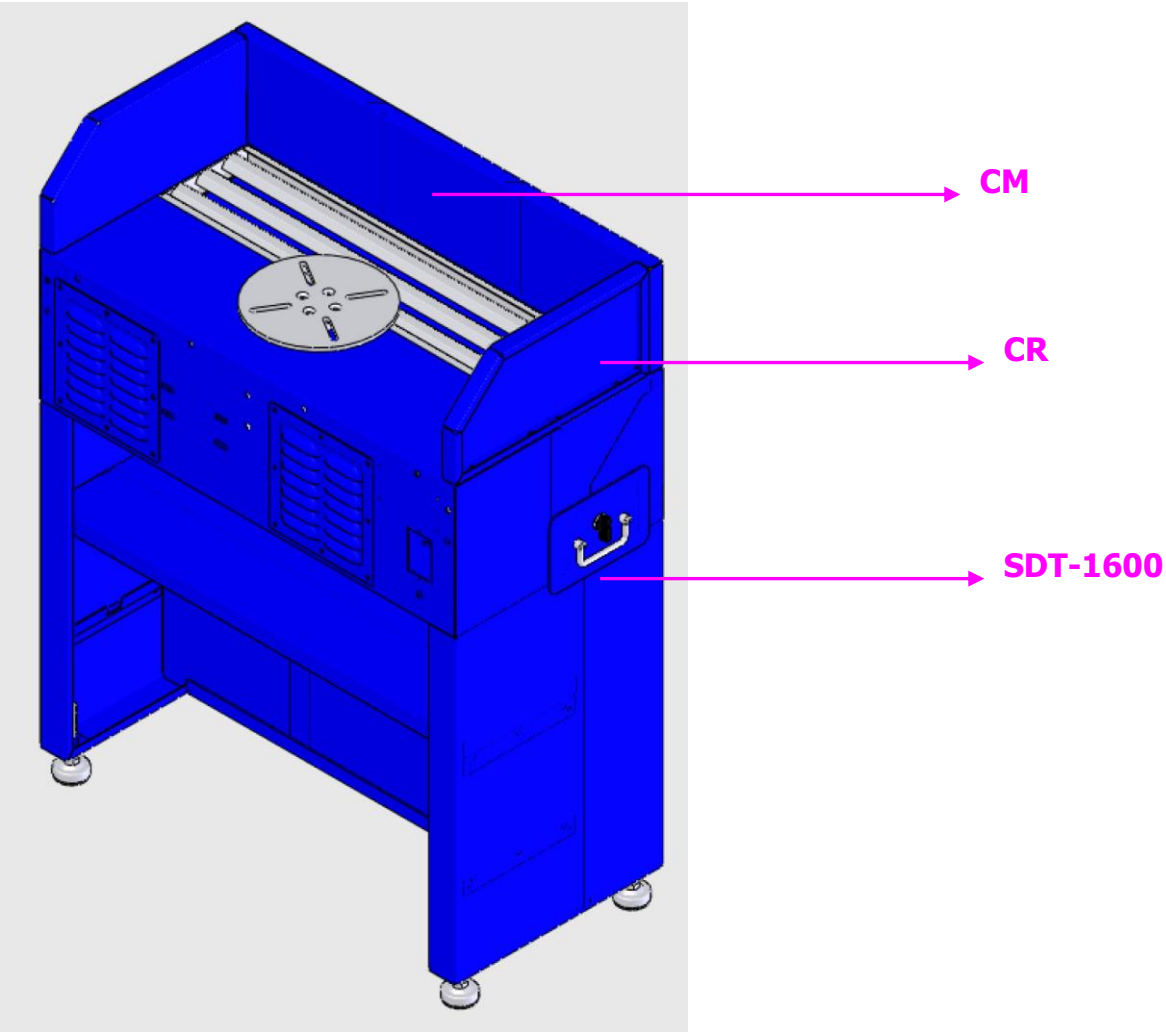
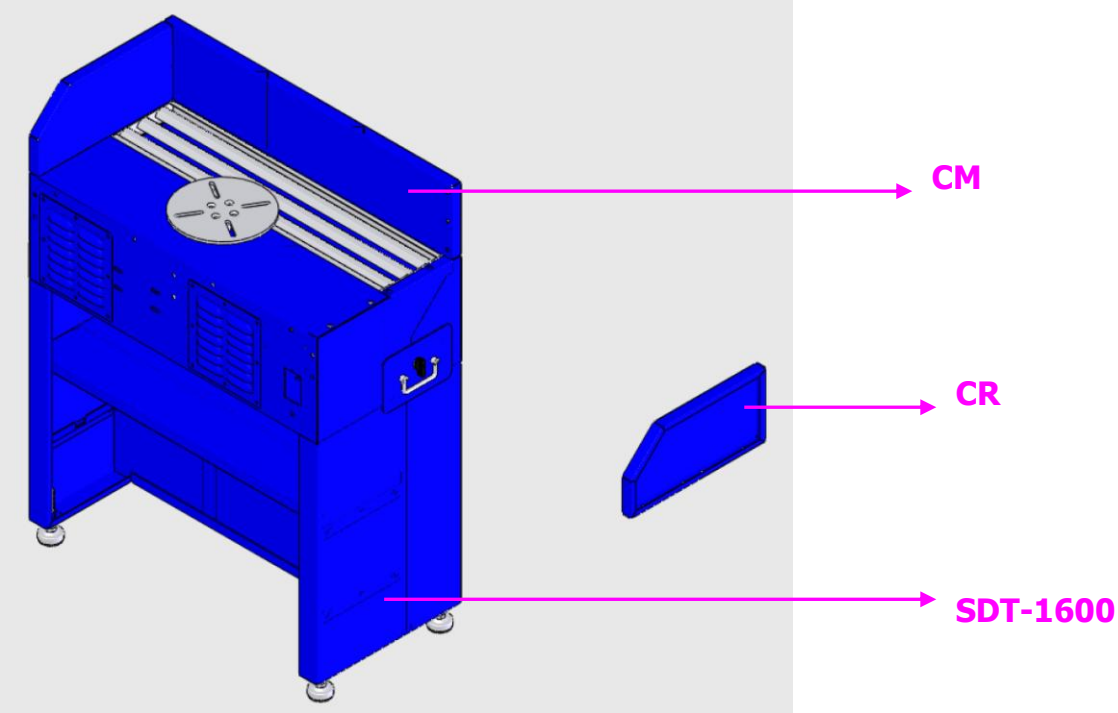

# ✚ Installations for SDT-1600.

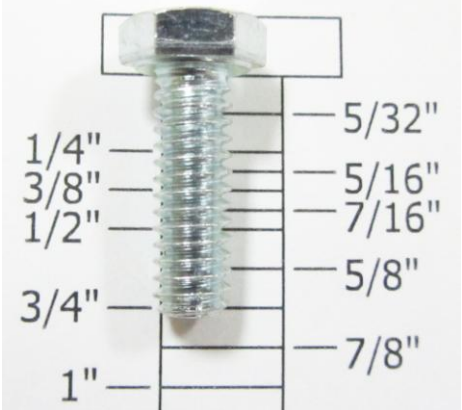

## ✚ Installations for SDT-1600.

- Take out the number: **STB-L**, **STB-R** and **STB-R**
- Fasten **STB-L**, **STB-R** and **STB-R** to **SDT-1600** with:

Part name	Description	Photos	Q'ty	Grainger Model #
Hex Screw	1/4" x 3/4"		6	1UY24
Flat Washer	1/4" x OD19 x 2T		6	*1JY29

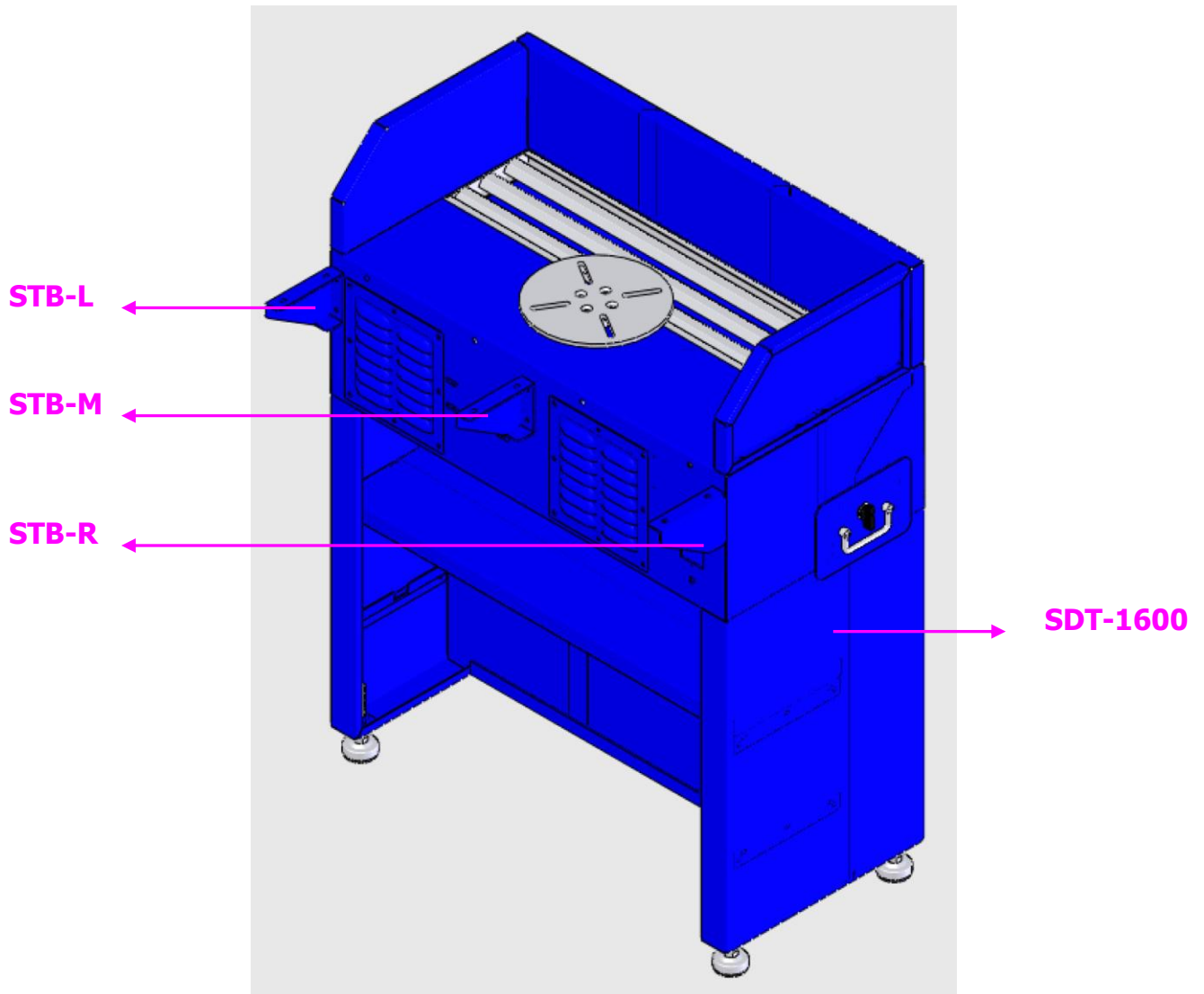
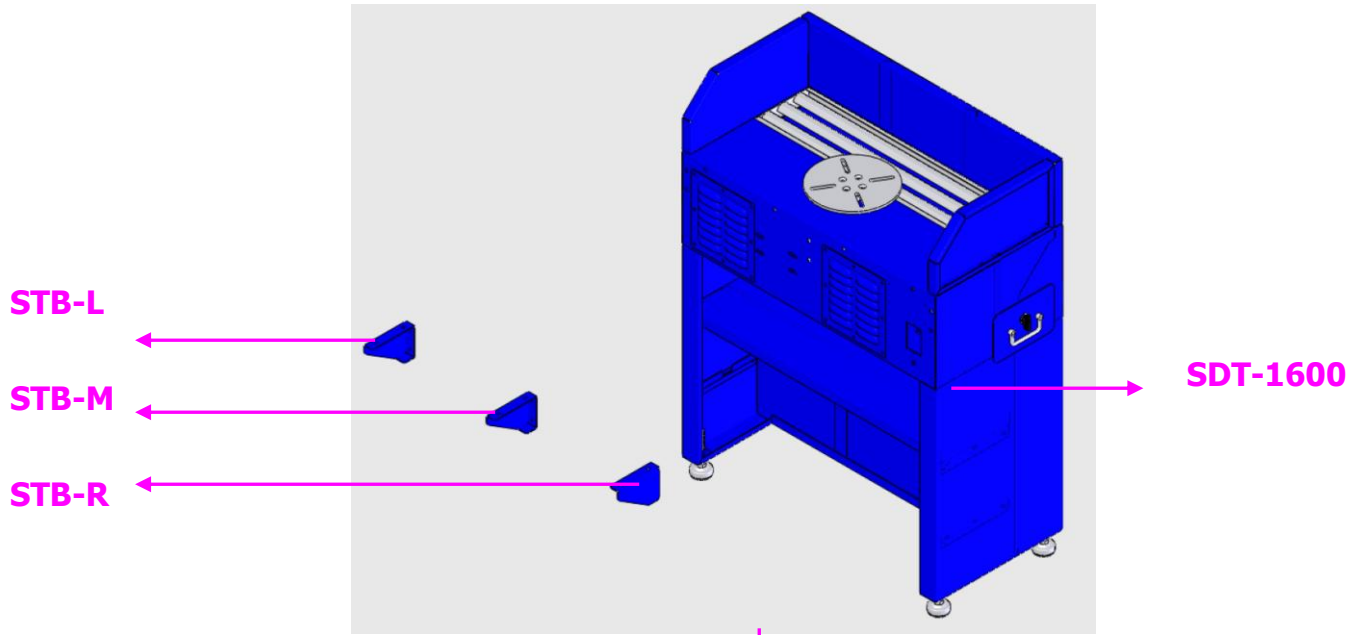

**(\*) Hardware item at similar spec available locally.**

# ✚ Installations for SDT-1600.



## ✚ Installations for SDT-1600.

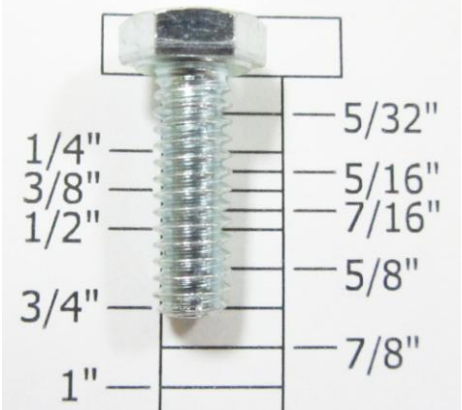

- Take out the number: **STB**
- Fasten **STB** to **SDT-1600** with:

Part name	Description	Photos	Q'ty	Grainger Model #
Hex Screw	1/4" x 3/4"		4	1UY24
Flat Washer	1/4" x OD19 x 2T		4	*1JY29

**(\*) Hardware item at similar spec available locally.**

## ✚ Installations for SDT-1600.

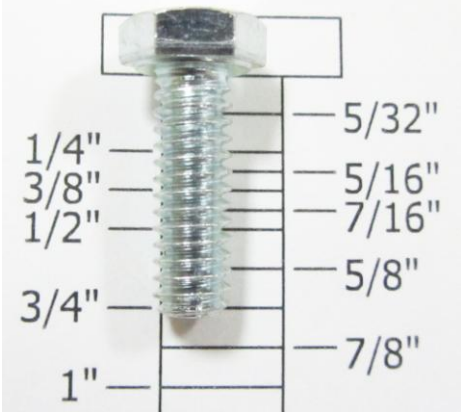
- Fasten **STB** to **STB-L**, **STB-R** and **STB-R** with:

Part name	Description	Photos	Q'ty	Grainger Model #
Hex Screw	1/4" x 3/4"		6	1UY24
Flat Washer	1/4" x OD19 x 2T		8	*1JY29
Hex Nut	1/4"		2	2FE45

(\* Hardware item at similar spec available locally.

## ✦ Installations for SDT-1600.

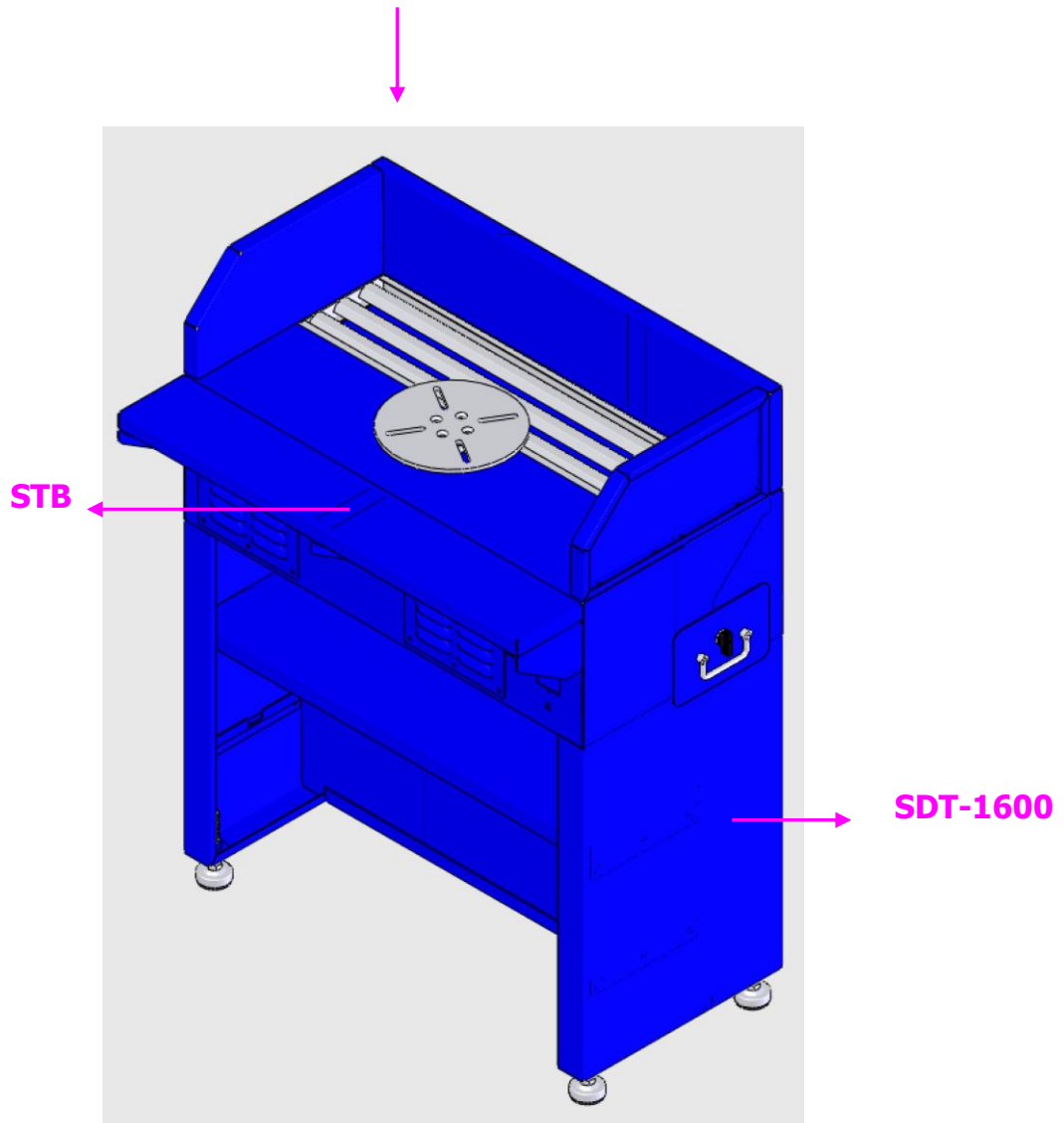
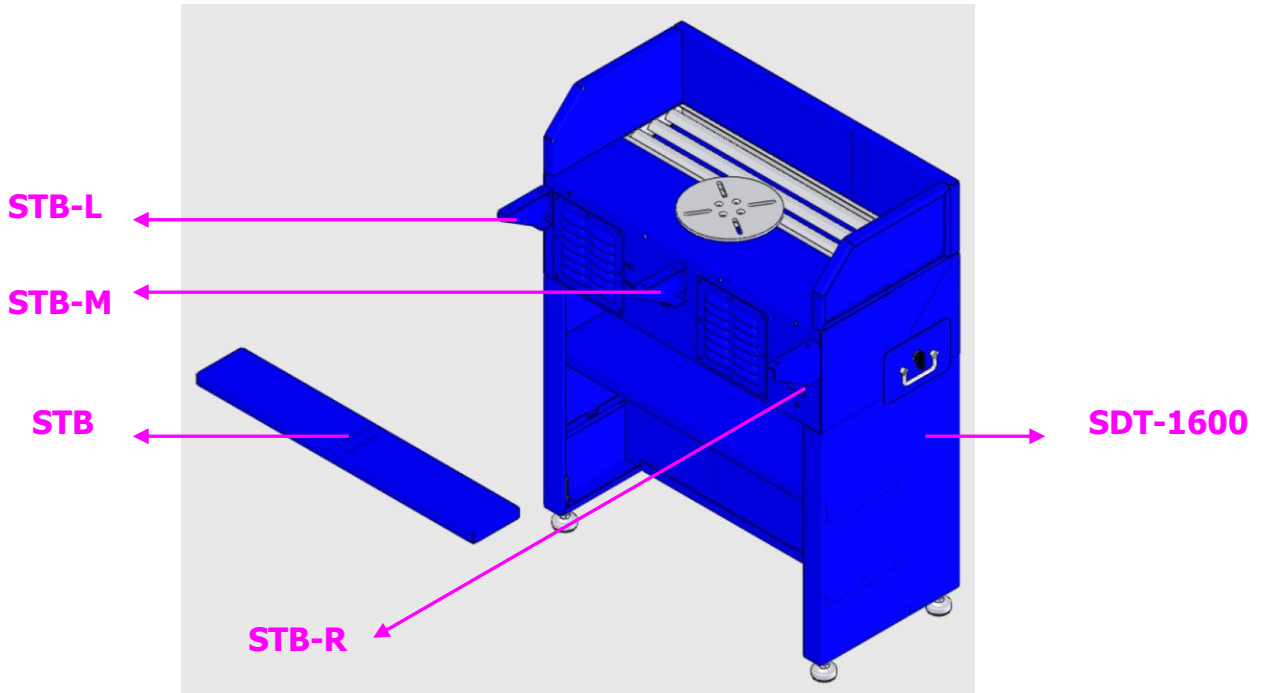



## ✚ Installations for SDT-1600.

- Take out the number: **IE**.
- Fasten **IE** to **SDT-1600** with:

Part name	Description	Photos	Q'ty	Grainger Model #
Hex Screw	5/16" x 3/4"		6	1YU33
Flat Washer	5/16" x OD23 x2T		6	*1JY31

**(\*) Hardware item at similar spec available locally.**

# ✚ Installations for SDT-1600.

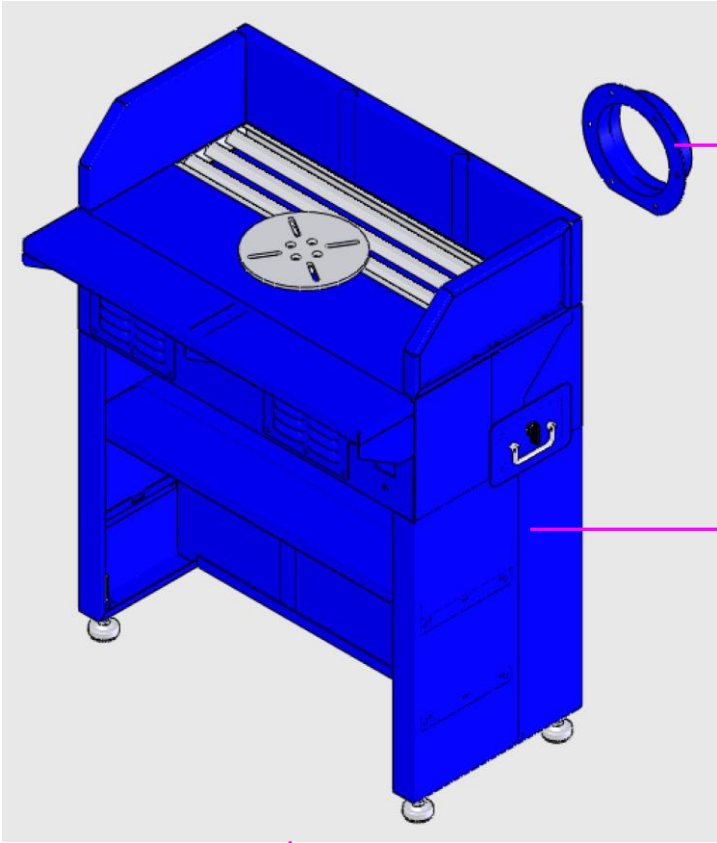

IE

SDT-1600

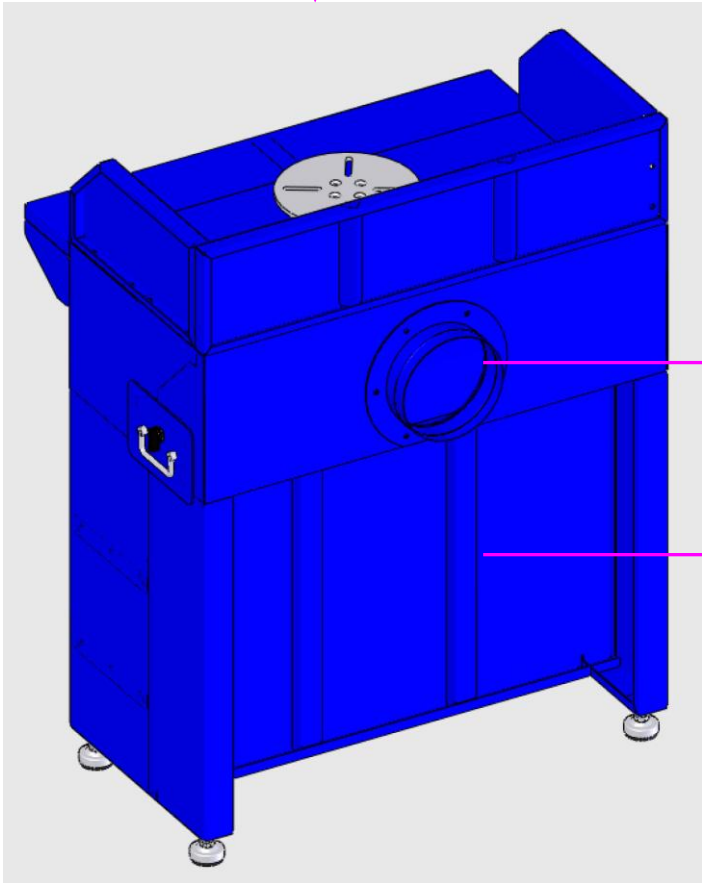

IE

SDT-1600

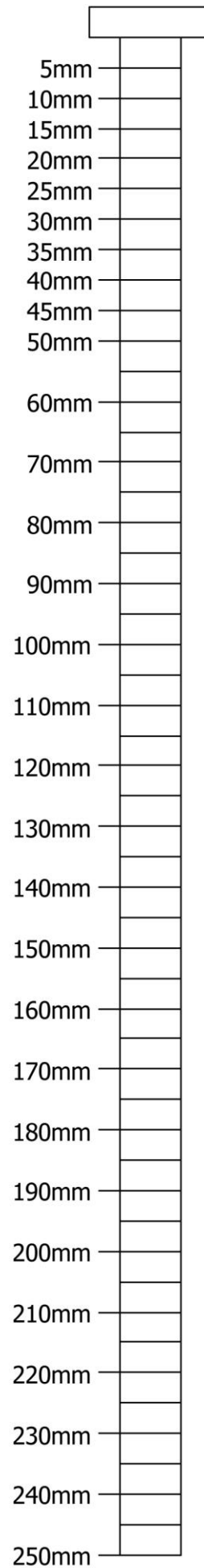
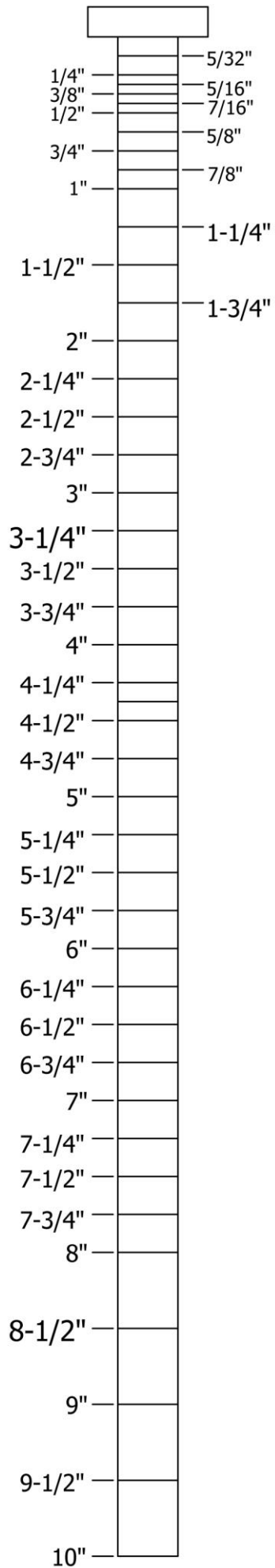

Flat Washer: 1/4"

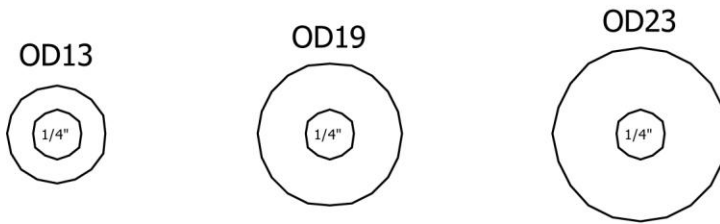

Flat Washer: 5/16"

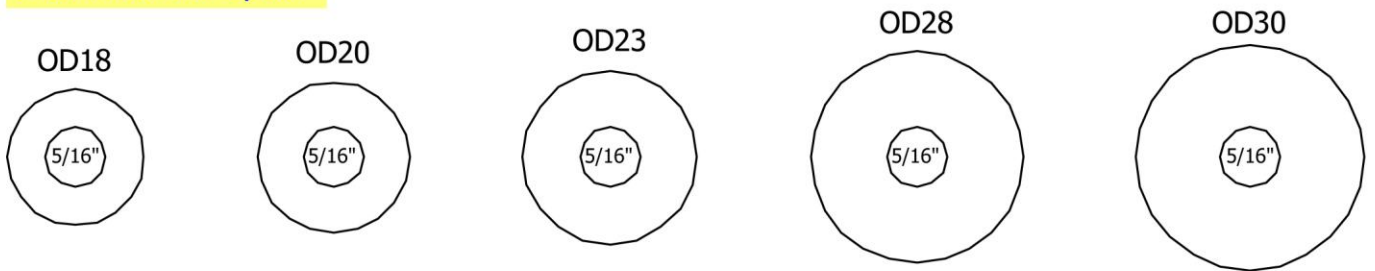

Flat Washer: 3/8"

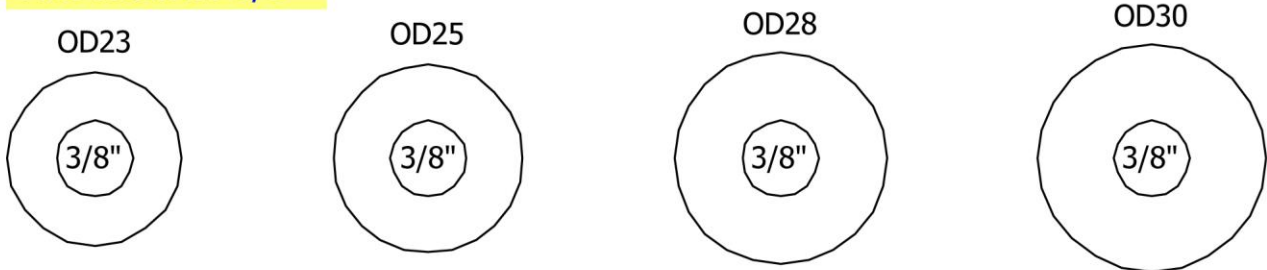

Flat Washer: 1/2"

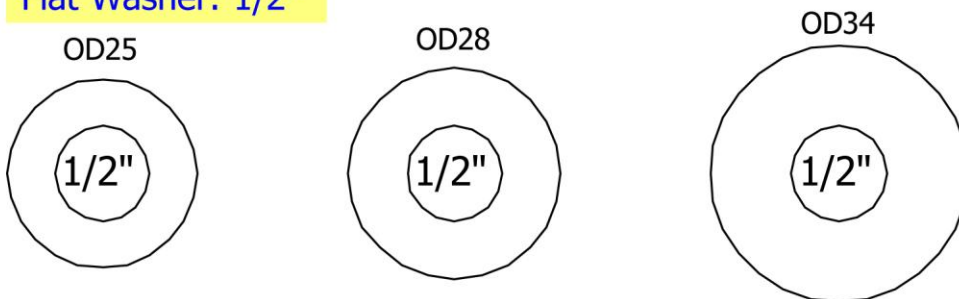

Flat Washer: 7/16"

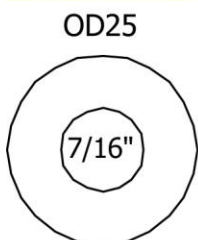

Flat Washer: 5/8"

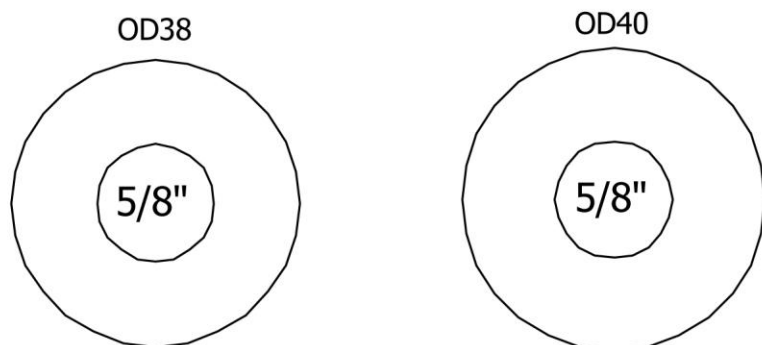

**HEX NUT**

3/16"



HEX NUT

1/4"



HEX NUT

5/16"



HEX NUT

3/8"



HEX NUT

1/2"

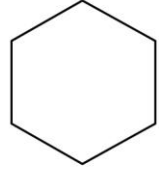

HEX NUT

**NYLON HEX NUT**

1/4"



NYLON HEX NUT

5/16"



NYLON HEX NUT

3/8"



NYLON HEX NUT

1/2"



NYLON HEX NUT