



Date: December 05, 2012

Project:

To: Q-Air Environmental Controls

Attn:

Recommended Equipment:

(1) SPB-03B Spray Booth: 3HP:

- 3HP / 575V / 60Hz / 3-phase

- to sit on customer's current and existing work bench

Avani Environmental Intl. Inc.

95 Cypress Drive

Youngsville, NC 27596

www.avanienvironmental.com

Phone: (919) 570-2862

Fax: (919) 570-2863

Email: info@avanienvironmental.com

www.weldingbooths.com

DO NOT SCALE

IF IN DOUBT ASK



Revisions

Rev	Description	Date	Approved
-----	-------------	------	----------

Synthetic Fiber Filter

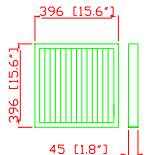

Pre-Primary Filter

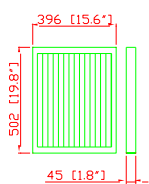

Fiber Glass

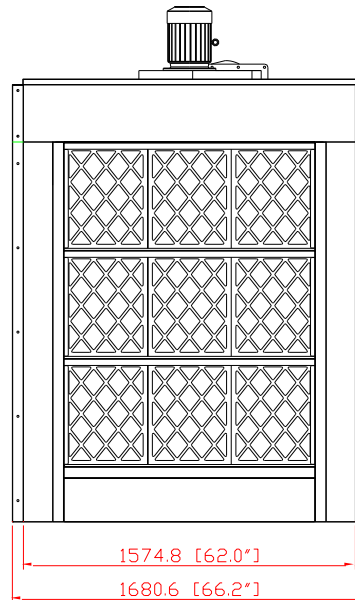
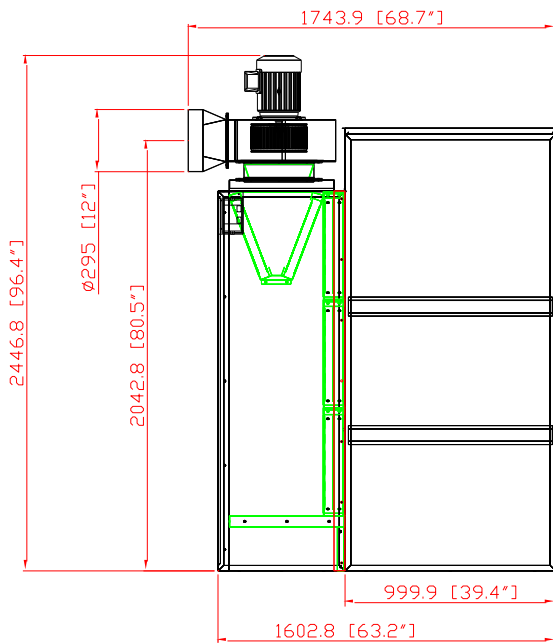
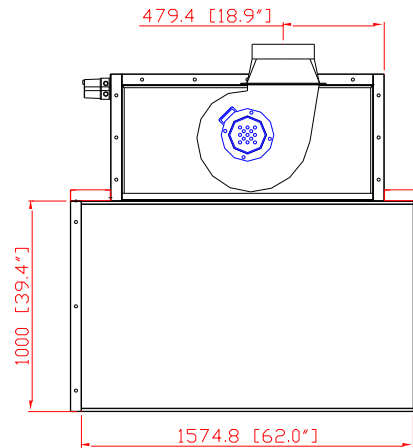
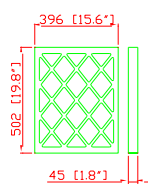

- SPB-03B 3HP Dry Spray Booth SPECIFICATION -

- Motor: 3HP x 1 pc
- ***TEFC Motor
- ***Aluminum Impeller

- Electric Spec: 575V / 60Hz / 3Ph / 3.25A (wired at 575V)
- Airflow: 1900 CFM (Nominal: 3300 CFM)

Filtration Stages:

1. Fiber Glass:
 - spec: 16" x 20" x 2"
 - filter efficiency: 30%
 - required quantity: 9 pcs
2. Pre-Primary Filter:
 - spec: 16" x 20" x 2"
 - filter efficiency: 35%
 - required quantity: 9 pcs
3. Synthetic Fiber Filter:
 - spec: 16" x 16" x 2"
 - filter efficiency: 60 ~ 65%
 - required quantity: 6 pcs

- Dimension: 66.2" x 68.7" x 96.4"
(1680.6 x 1743.9 x 2446.8mm)

- N.W.: 600 lbs (272 kgs)
- G.W.: 776 lbs (352 kgs)

- Construction: 14 Gauge
- Paint Color: powder coated Blue
- UL control box

AVANI ENVIRONMENTAL INTL. INC. Sales Department
95 Cypress Drive (919) 570-2862
Youngville, NC 27596 info@avanienvironmental.com

Date	Name	Part Number:	Title:
2012-12-05	***	dry spray booth	SPB-03B
Drawn by:	Checked by:		

The drawings, AutoCAD, 3-D Models, and specifications are the property of Avani Environmental Intl. Inc. (AE) and may not be reproduced, distributed, modified, or otherwise used, except provided herein, without the express written permission of AE.

Size	Scale	Drawing Number:
A	1 = 30	***

