

ARRANGEMENT 4

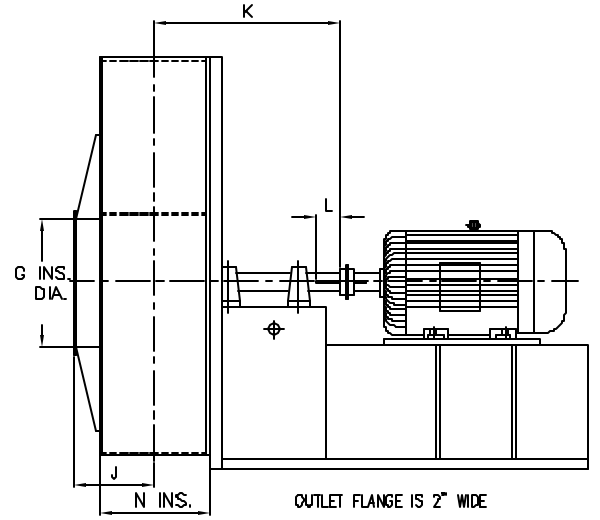
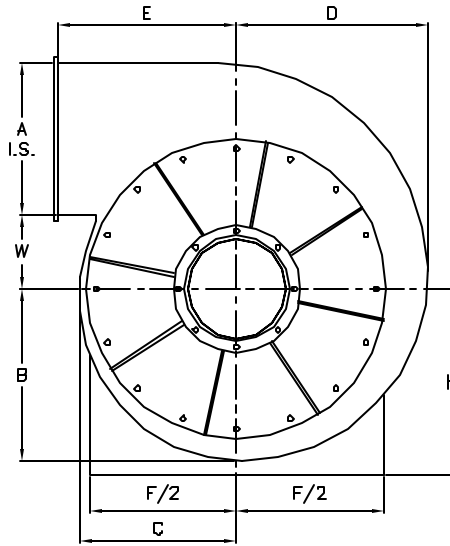

ARRANGEMENT 8

SIZE 19 -79.4 WHEEL WIDTH

DIMENSION - INCHES

FAN SIZE	A	B	C	D	E	F	G	H	J	K (ARR.8)	L (ARR.8)	N	W
13	12-5/8	17-1/16	15-7/16	18-11/16	17-7/16	15-7/8	13	23	6-1/4	28	4	11-1/16	7-3/16
15	14-1/2	19-9/16	17-11/16	21-7/16	19-7/8	24	15	26	10-1/8	30-5/16	5	12-3/4	8-5/16
17	16-7/16	22-1/16	19-15/16	24-3/16	22-1/4	27	17	29	11-1/16	31-15/16	6	14-3/8	9-3/8
19	18-1/4	24-1/2	22-1/8	26-7/8	24-11/16	30	19	32	11-3/16	34-9/16	7	14-3/8	10-1/2
21	20-3/16	27-1/16	24-7/16	29-11/16	27-1/8	33-1/2	21	35	14-1/32	36-5/8	7	17-11/16	11-5/8
23	22-1/8	29-3/16	26-5/16	32-1/16	29-5/8	37	23	39	15-1/8	40-3/16	7	19-5/16	12-3/4
26	24-15/16	32-15/16	29-11/16	36-3/16	33-3/16	42-1/2	26	44	17-7/32	42-15/16	7	22-3/16	14-7/16
29	27-3/4	36-13/16	33-3/16	40-7/16	37	46-1/4	29	48	18-7/32	48-3/4	8-1/2	24-17/32	16-5/16

FAN SIZE	A	B	C	D	E	F	G	H	J	K (ARR.8)	L (ARR.8)	N	W
15													
17													
19													
21													
23													
26													
29													

ITEM NO	IDENTIFICATION	NO REQ'D	FAN SIZE	DISCH. & ROT.	WHEEL TYPE	CL.	PERFORMANCE							MOTOR DATA						
							C.F.M.	O.V.	S.P.	R.P.M.	B.H.P.	TEMP.	ELEV.	H.P.	R.P.M.	CURRENT	FRAME	TYPE		

ITEM NO	DRIVE DATA				MOTOR	VIBR. BASE TYPE	SPECIAL FEATURES	SPECIAL FEATURES	
	MTR.SHEAVE	FAN SHEAVE	BELTS	CENTER				A=FLANGED OUTLET	H=SPLIT HOUSING
								B=FLANGED INLET	J=SPECIAL FINISH-SEE NOTES
								C=OUTLET DAMPER	SPARK RESISTANT
								D=CLEANOUT DOOR; TYPE:	CONSTRUCTION, TYPE 'c'
								1.QUICK CLAMP	L=INLET COLLAR
								2.BOLTED	
								3.PLUG	
								E=SHAFT COOLER AND GUARD	
								F=DRAIN OPENING	
								G=SHAFT SEAL	

CUSTOMER _____

_____ P.O.# _____

JOB NAME _____

LOCATION _____



SERIES 9000 SIZES 13 TO 29
 ADJUSTABLE HOUSING ARRANGEMENT NO 4 & 8
SHELDONS ENGINEERING
 www.sheldonsengineering.com
 sales@sheldonsengineering.com

FURNISHED FOR SALES PURPOSE DIMENSIONS NOT CERTIFIED	DATE	SUBMITTED BY	SALES OFFICE
DRAWING CERTIFIED BY S.E. FURNISHED FOR APPROVAL-NOT RELEASED FOR PRODUCTION	DATE	ENGINEER	SO#
DRAWING CERTIFIED BY S.E. APPROVAL-NOT REQUIRED-RELEASED FOR PRODUCTION	DATE	ENGINEER	DWG#