

Laurus Silencer-Fan Fix

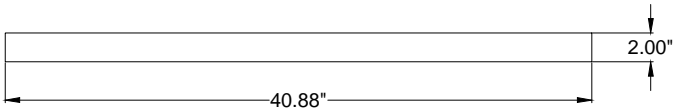
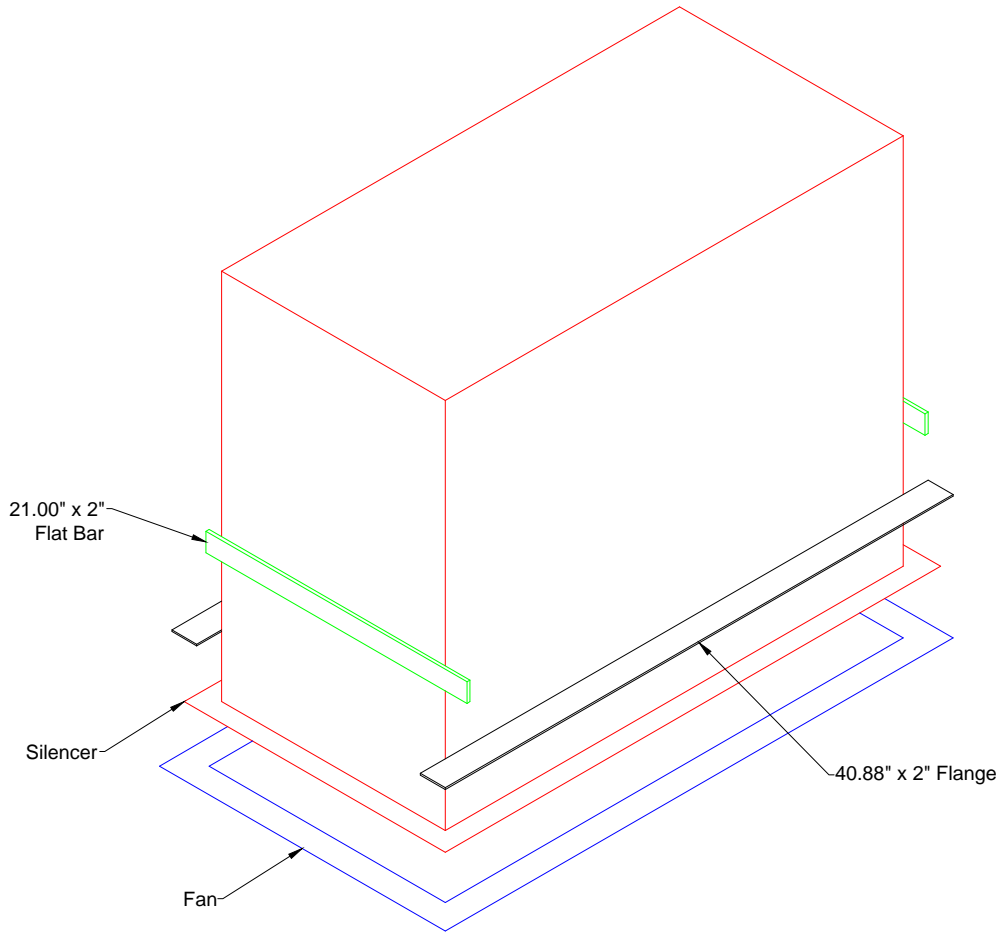

- Notes:
1. Need two galvanized 16 Ga cuts for one silencer
 2. Lay cuts on side of silencer
 3. Use Flat bar on ends, sandwich silencer to fan

Avani Environmental Intl. Inc.
95 Cypress Drive
Youngsville, NC 27596
P# 919-570-2862 F# 919-570-2863

Avani

Project: Laurus	
Drawing: Silencer-Fan Fix	
Date: 6-20-13	Drawn by:MDT
Sheet No:	