



**Date:** December 15, 2011

**Project:** Welding Booth po# 3478

**To:** Independent School District 318

**Attn:**

**Recommended Equipment:**

(2) sets WB-6055 (2 booths side-by-side) with 7.5HP, 4 cartridges top mount dust collector on booth top

---

**Avani Environmental Intl. Inc.**  
95 Cypress Drive  
Youngsville, NC 27596  
[www.avanienvironmental.com](http://www.avanienvironmental.com)

Phone: (919) 570-2862  
Fax: (919) 570-2863  
Email: [info@avanienvironmental.com](mailto:info@avanienvironmental.com)  
[www.weldingbooths.com](http://www.weldingbooths.com)

The drawings, AutoCAD, 3-D Models, and specifications are the property of Avani Environmental Intl. Inc. (AE) and may not be reproduced, distributed, modified, or otherwise used, except provided herein, without the express written permission of AE.















Hardware Bag D





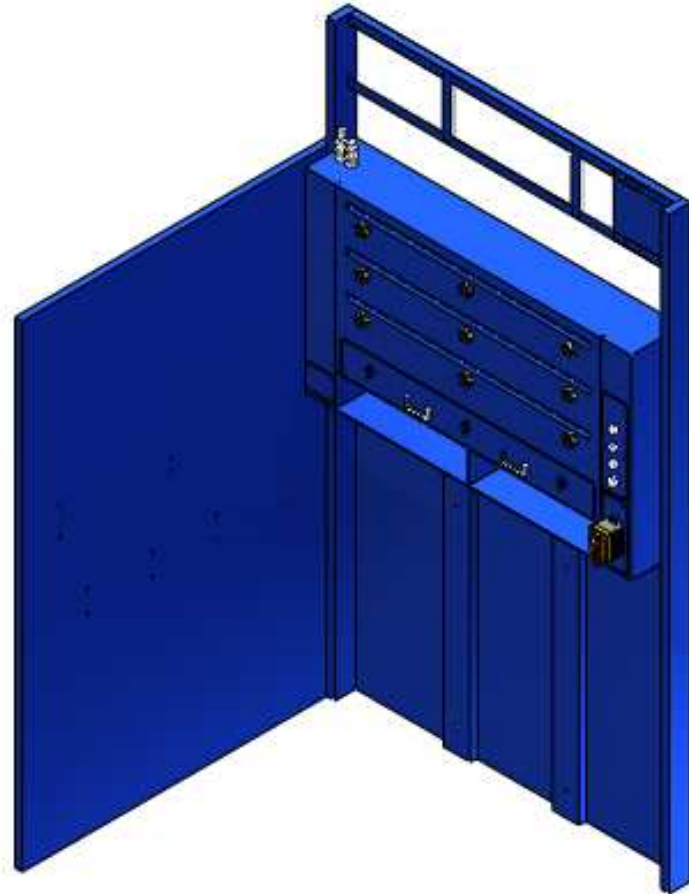

Hardware Bag E



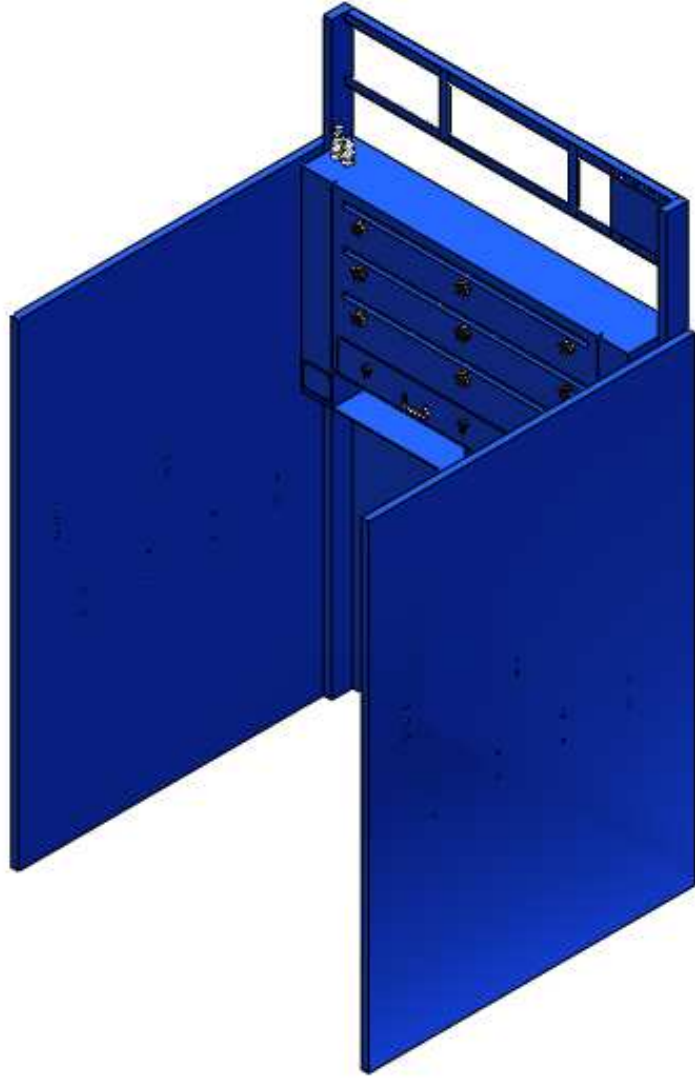



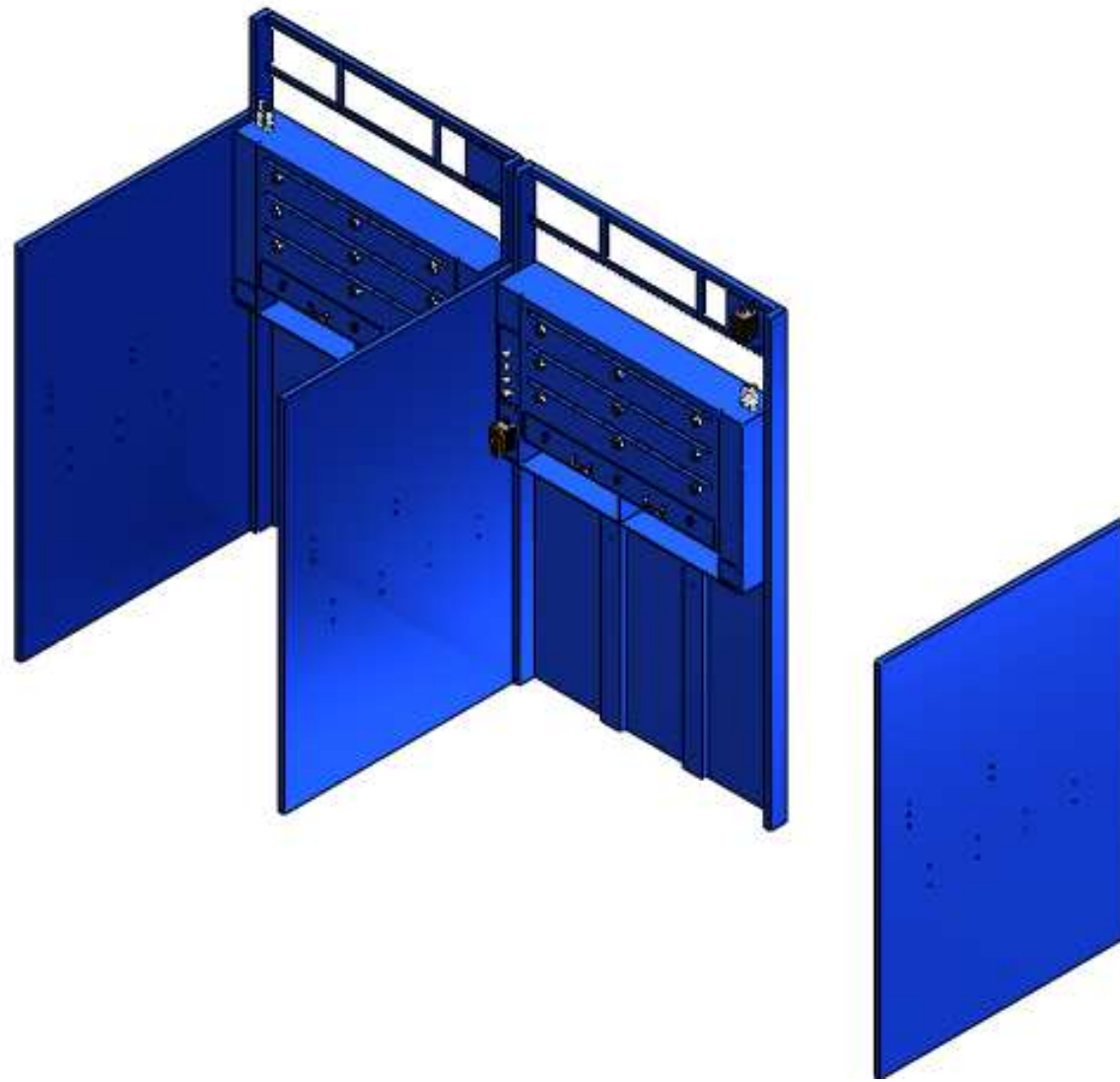

Hardware Bag C

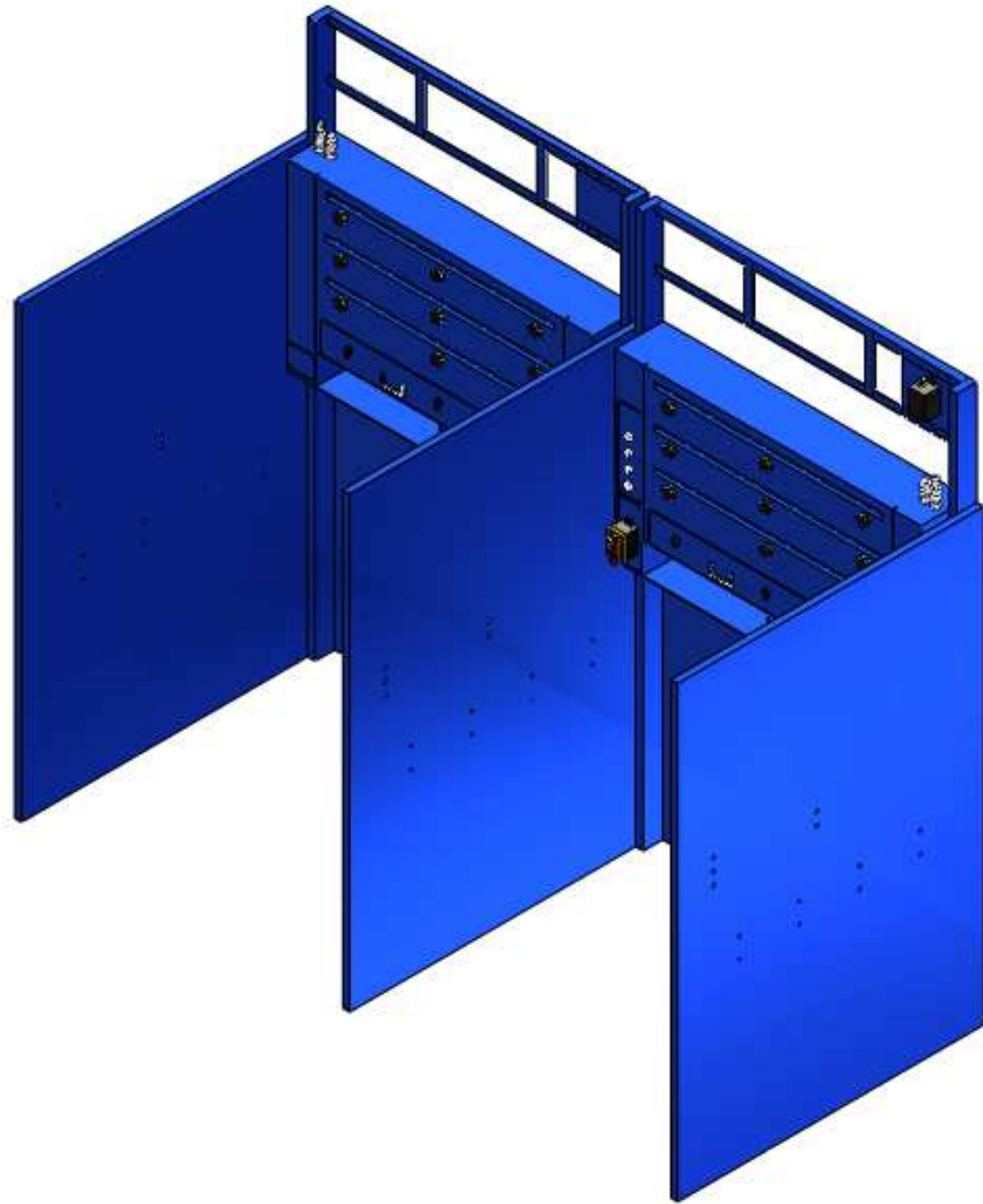



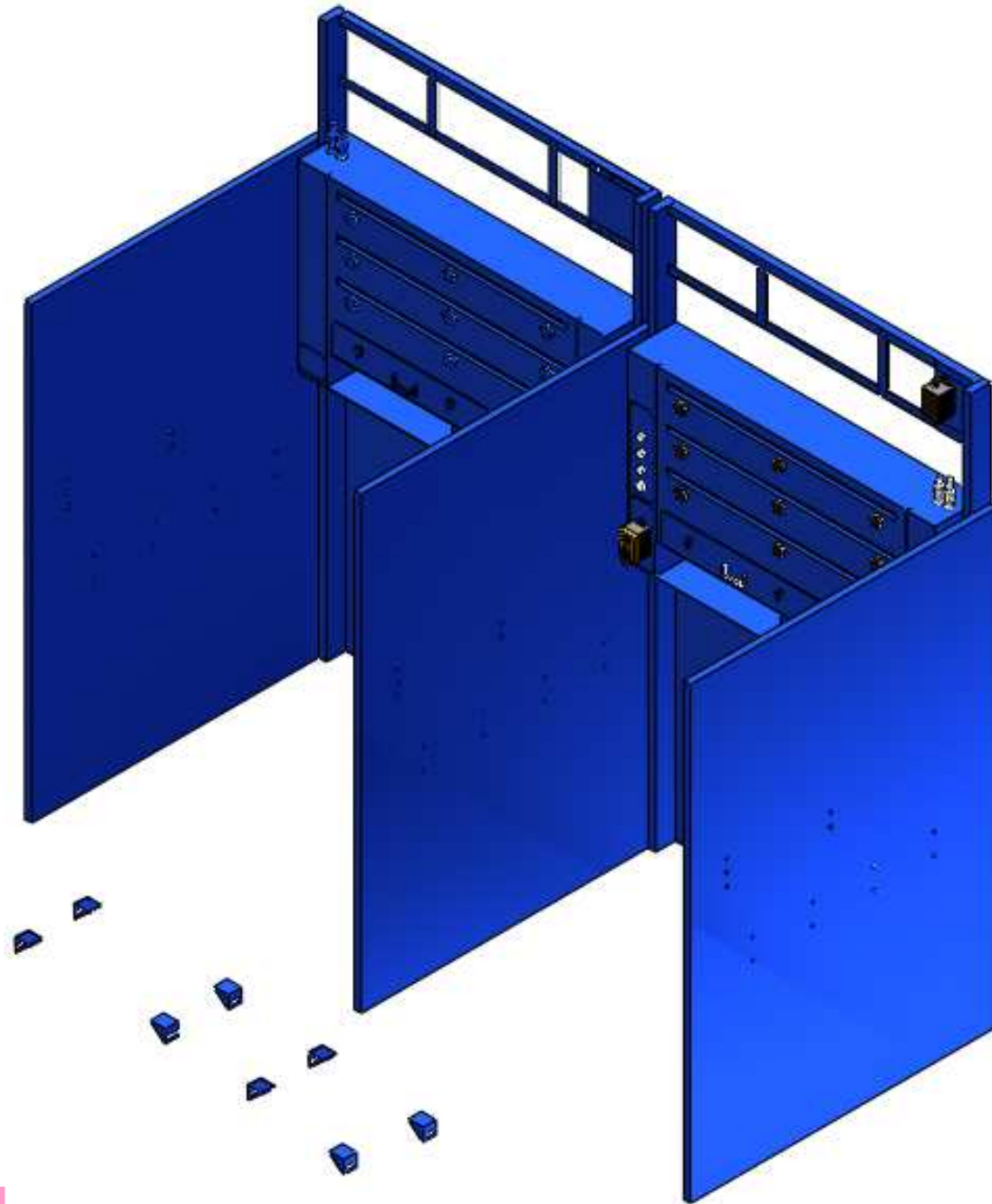

Hardware Bag K

Hardware Bag M



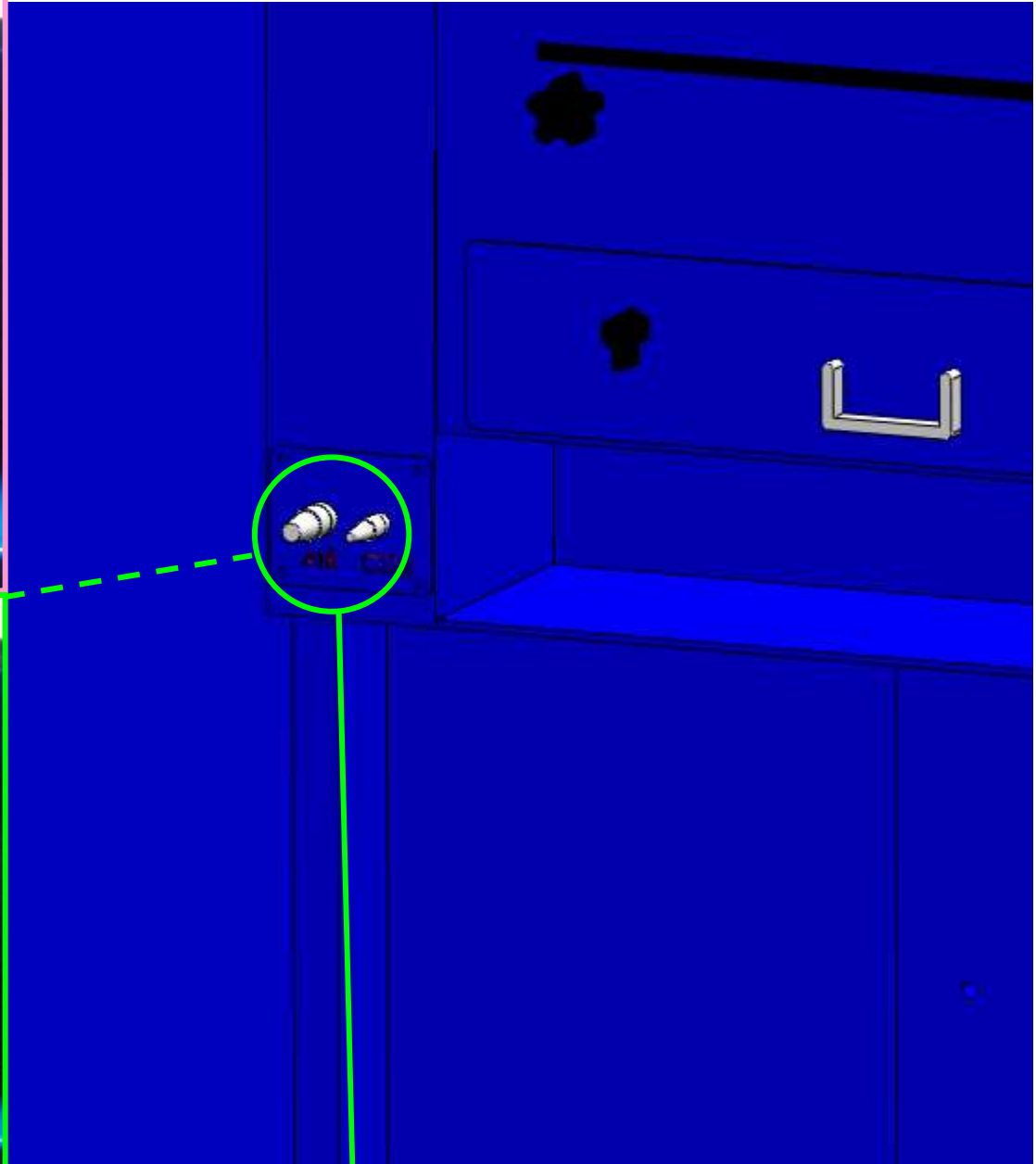

CO2 and air compressor connector

- Place the top mount dust collector TMC-7-4 on the top hood draft. Ensure that it sits properly and is secured with screws.

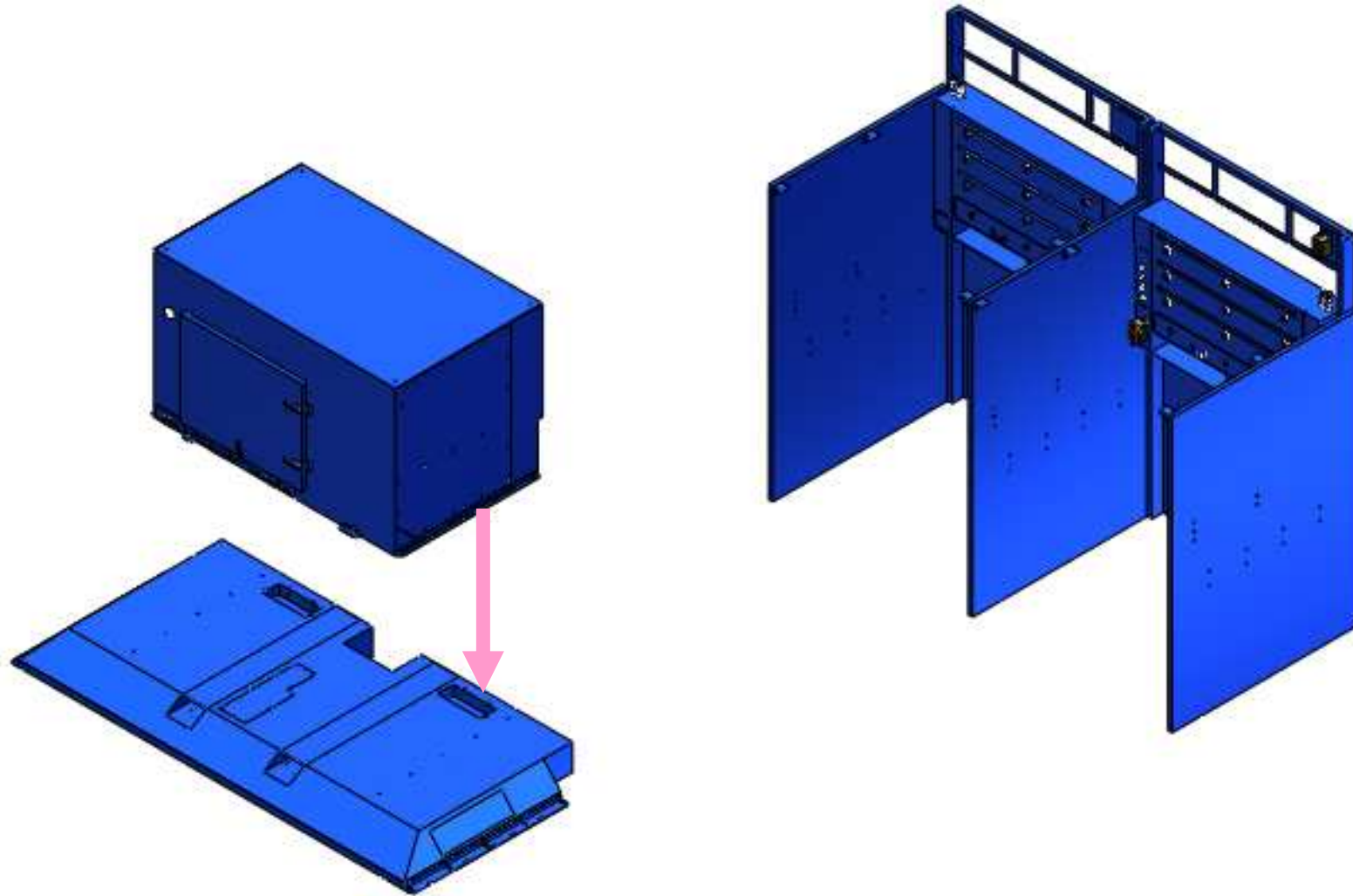

Hardware Bag R, S, T

- Place the TMC-7-4 and the top hood draft above the booths.

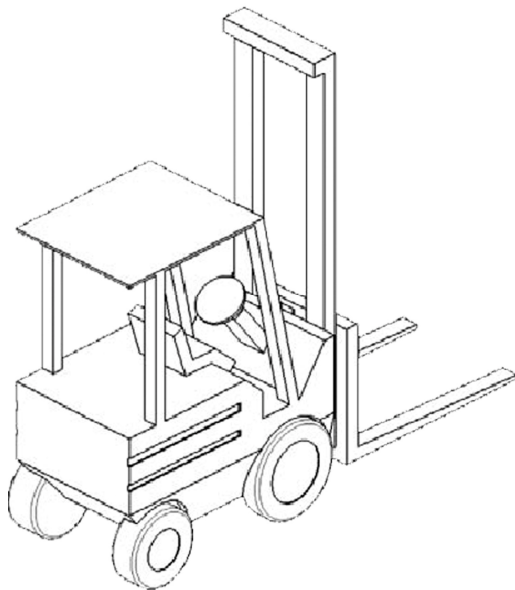
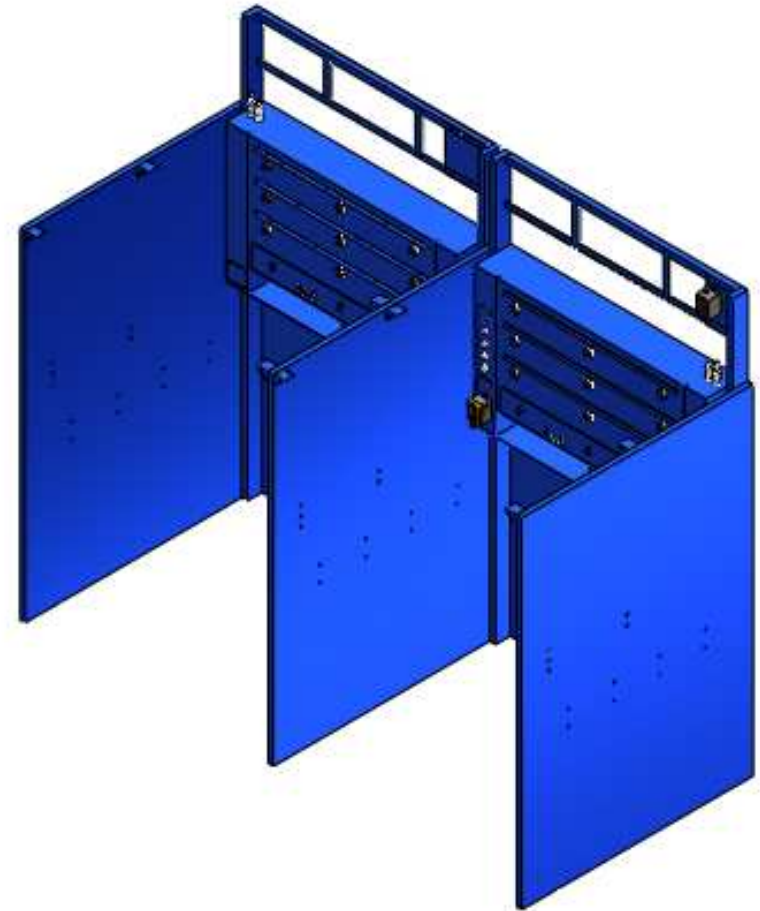
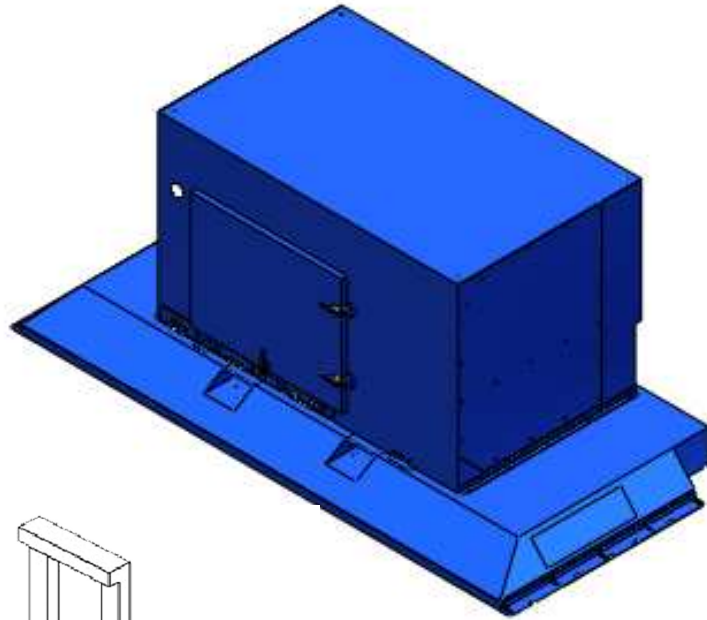



- Follow steps A, B, and C completely and fasten screws afterwards.

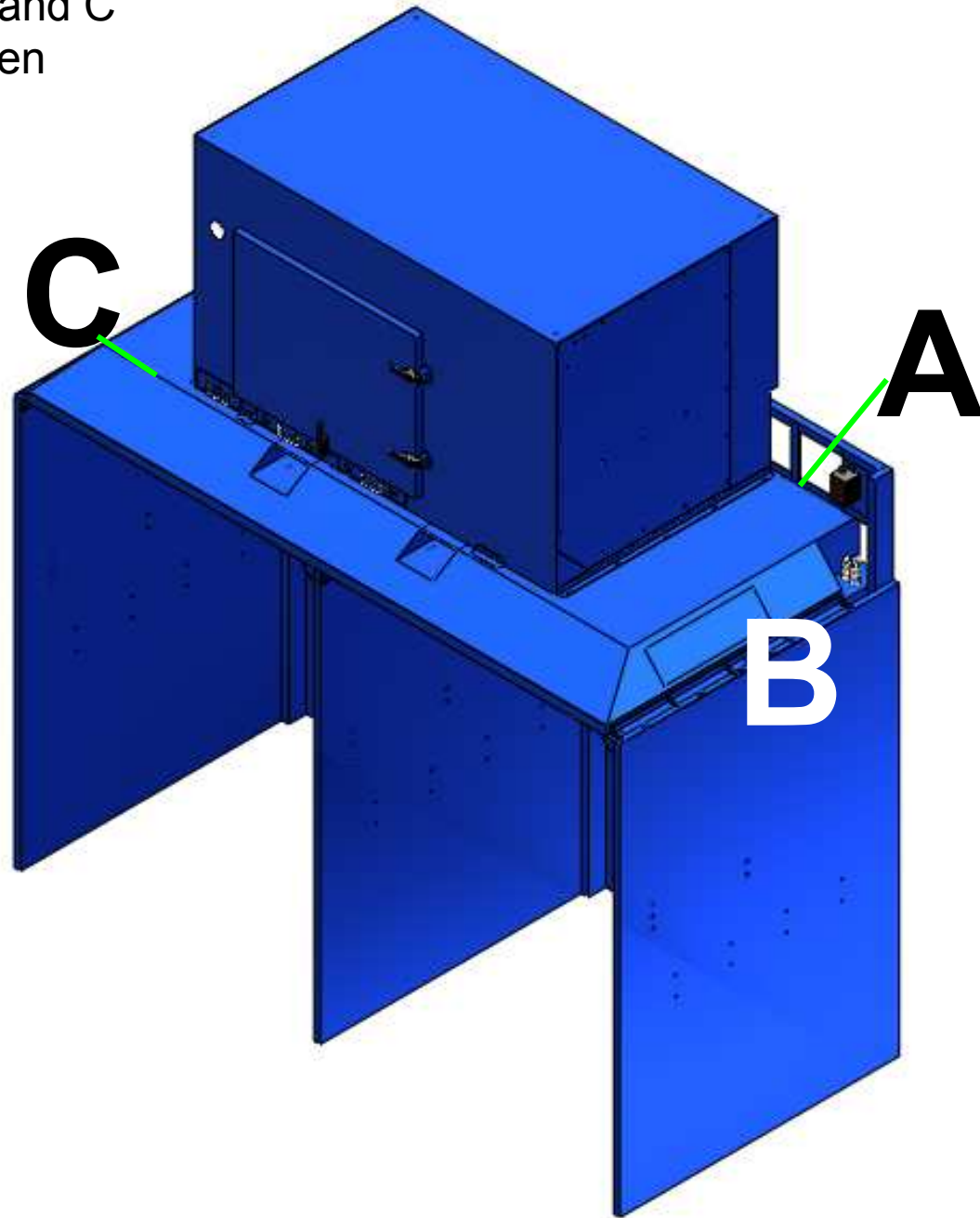



**A2:** Match the bolt patterns of the upper part of the backdraft to the bolt patterns of the TMC-7-4.

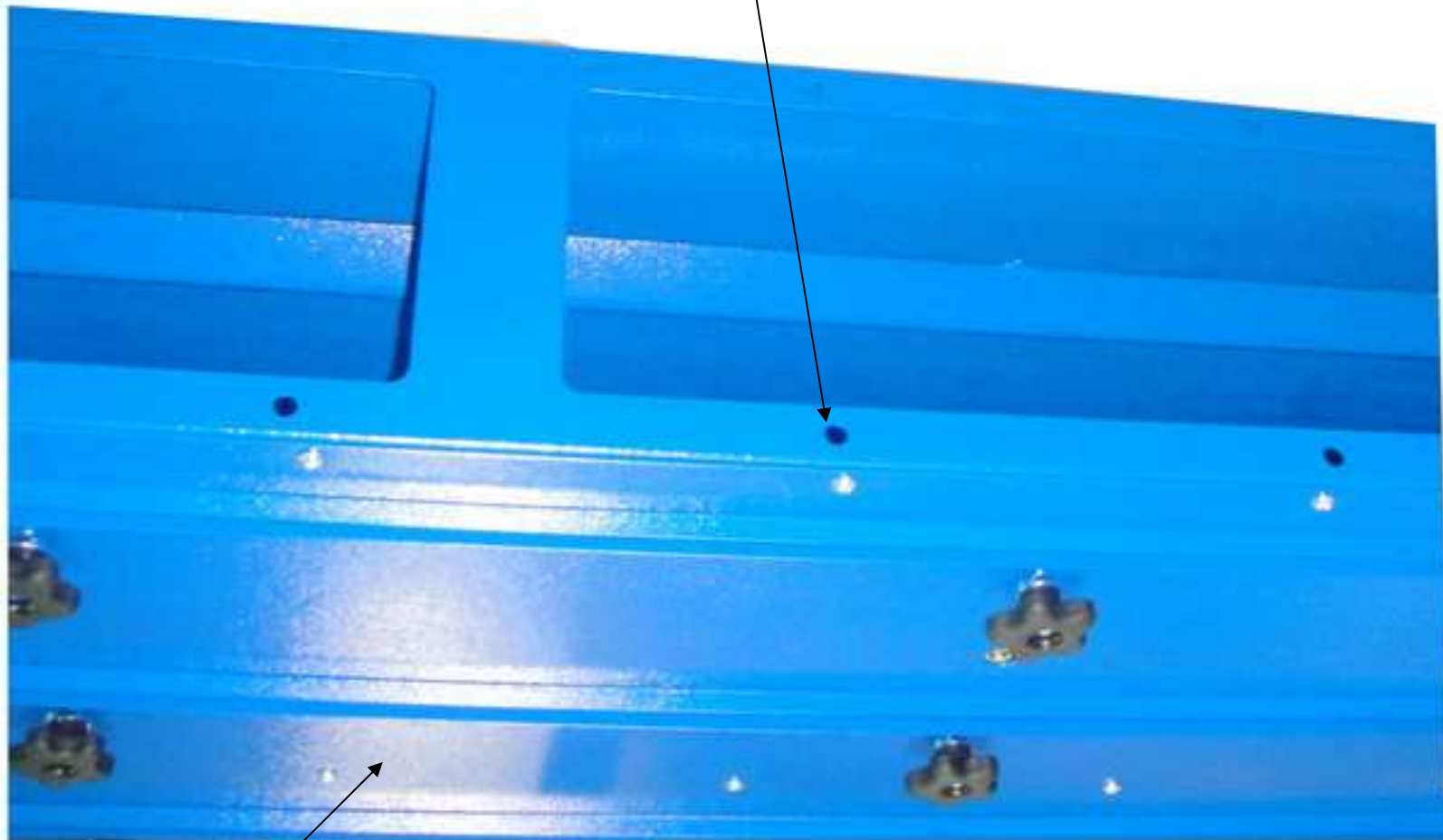

**A1:** Take off the front panel of the backdraft module.

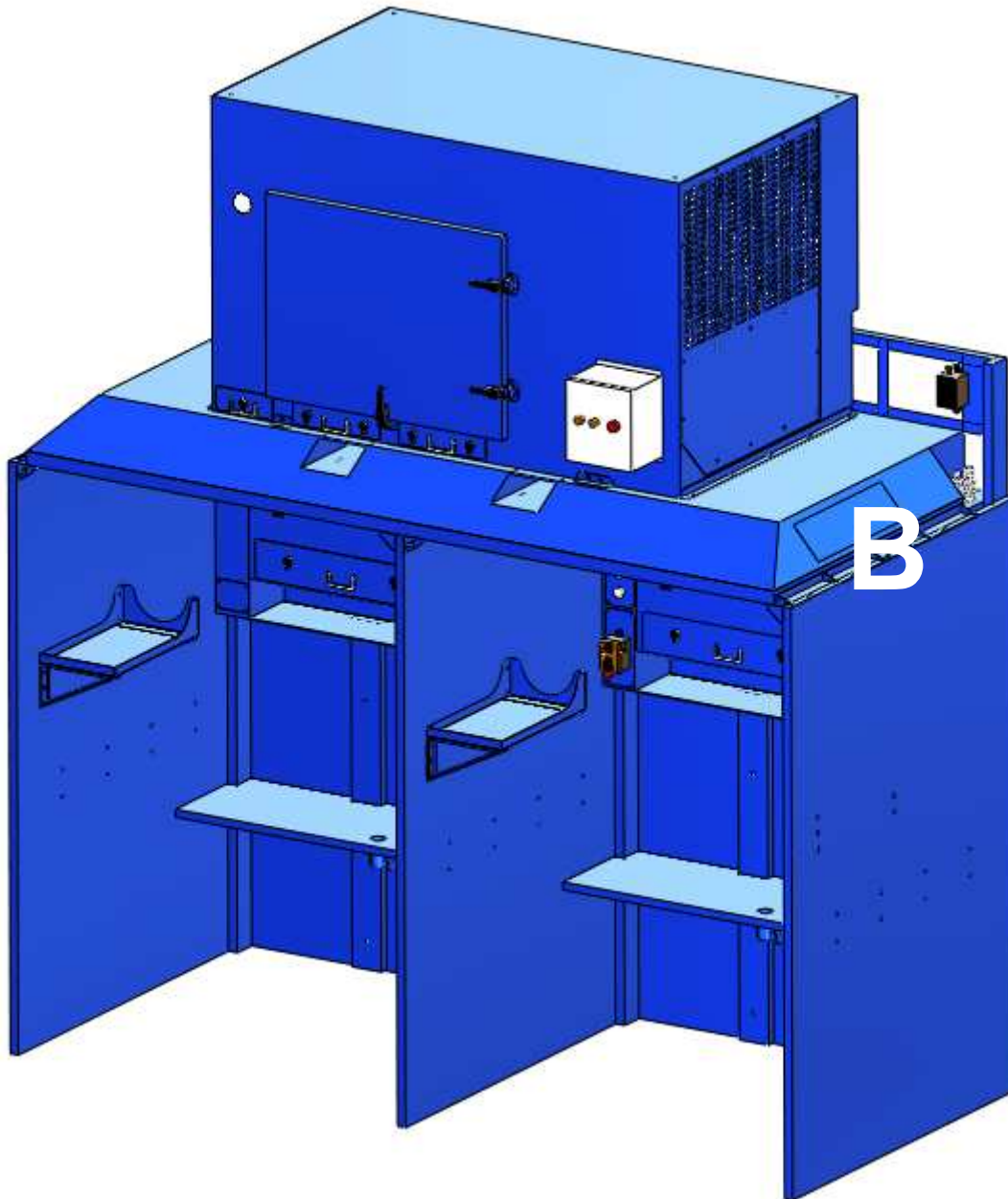

**B:** adjust the feet to ensure that the bolt patterns of the side panel match to the bolt patterns of the top hood draft.

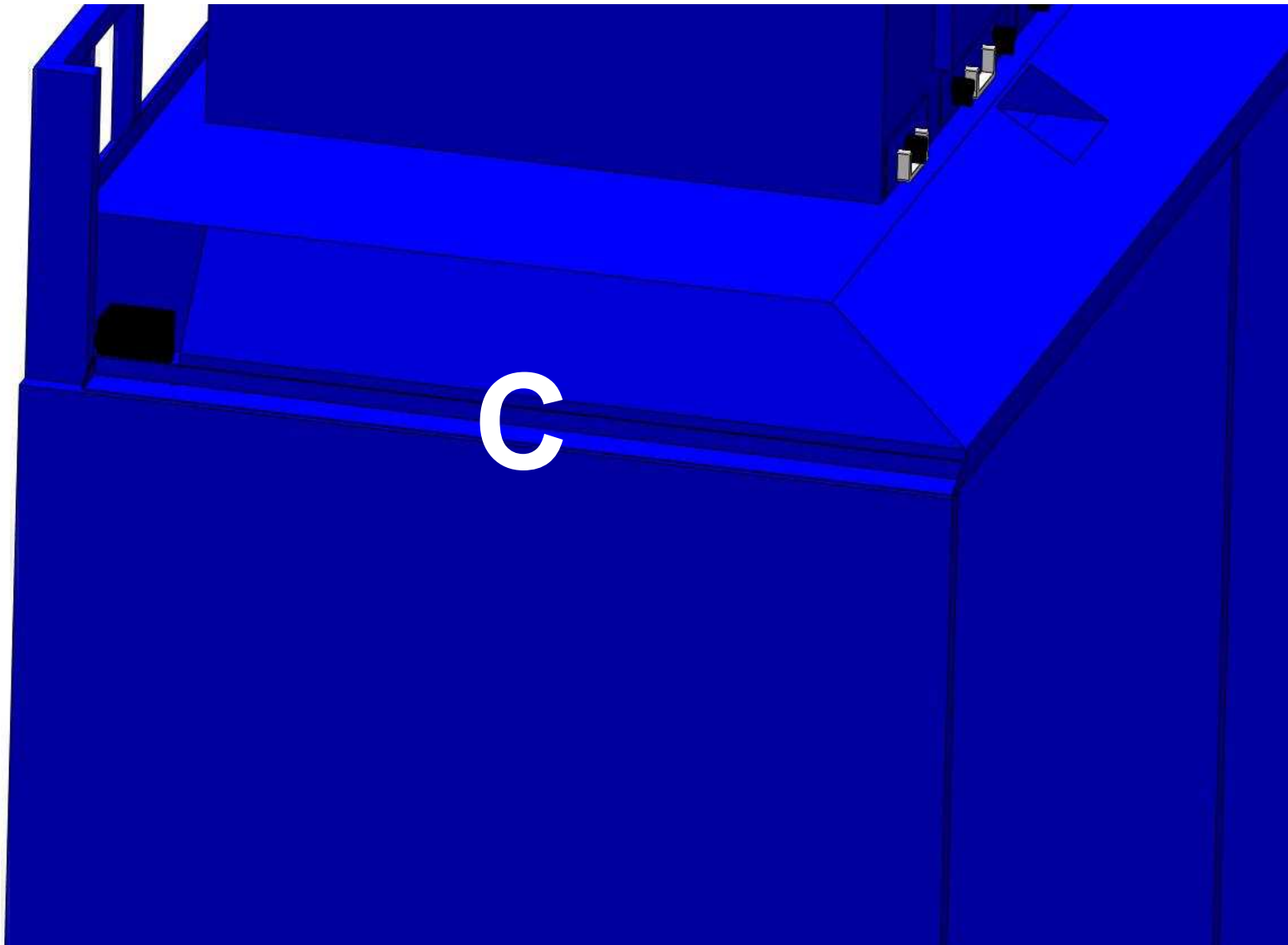

**C:** adjust the feet to ensure that the bolt patterns of the side panel match to the bolt patterns of the top hood draft.

•Attach the hypotenuse corner gussets bases at the panels, below the top hood draft, 2 pcs on each panel side, total 8 pcs for the two booths sitting together (pink circles).

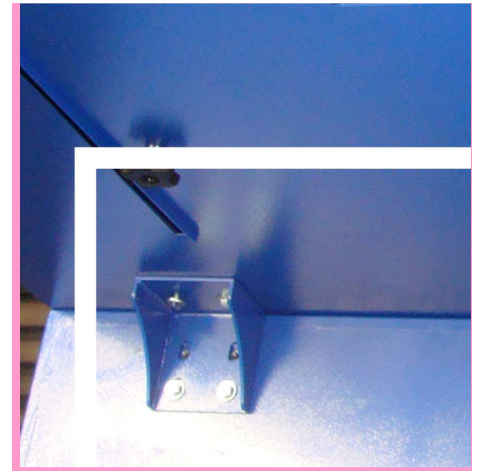
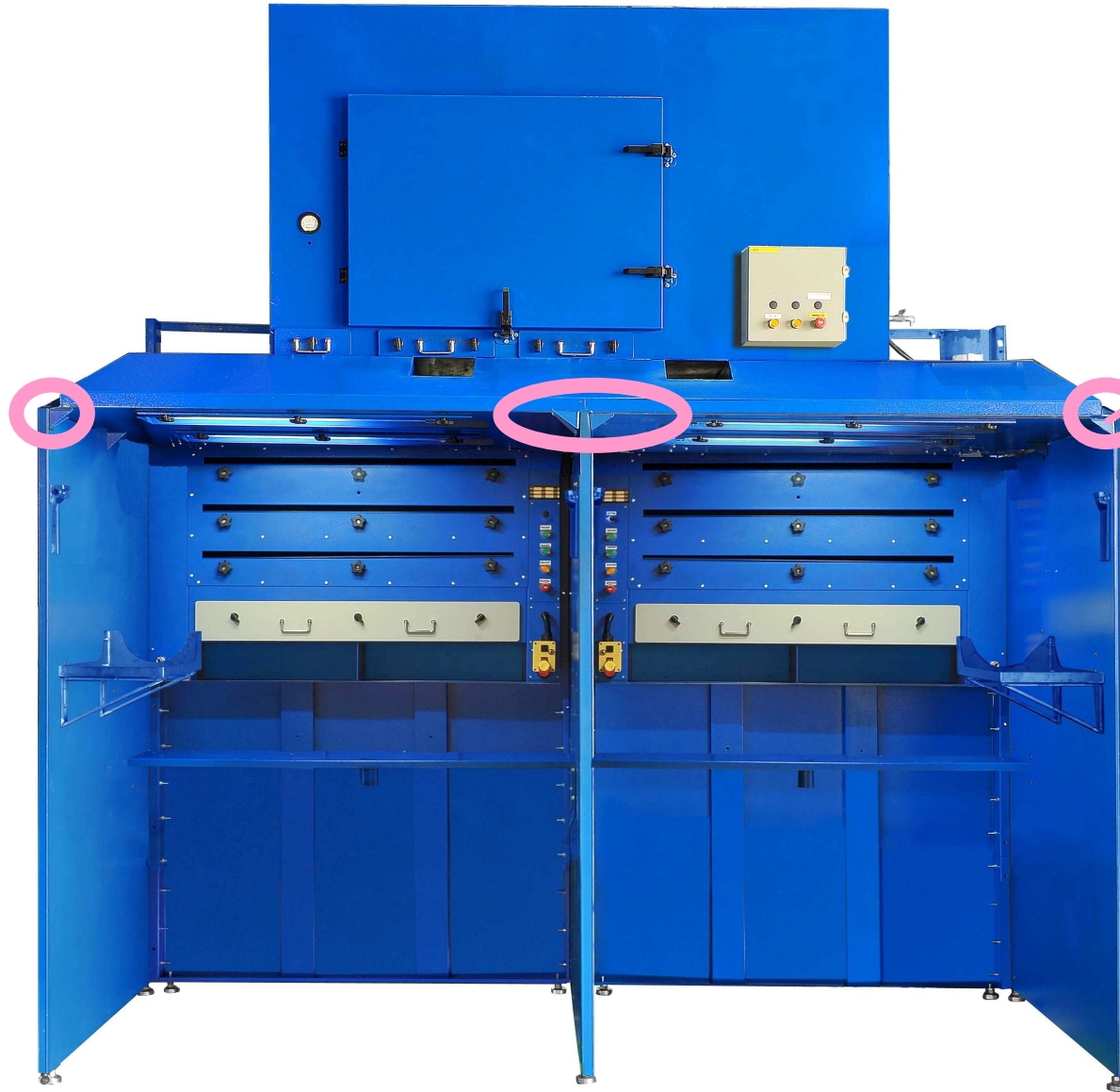

Hardware Bag K, M



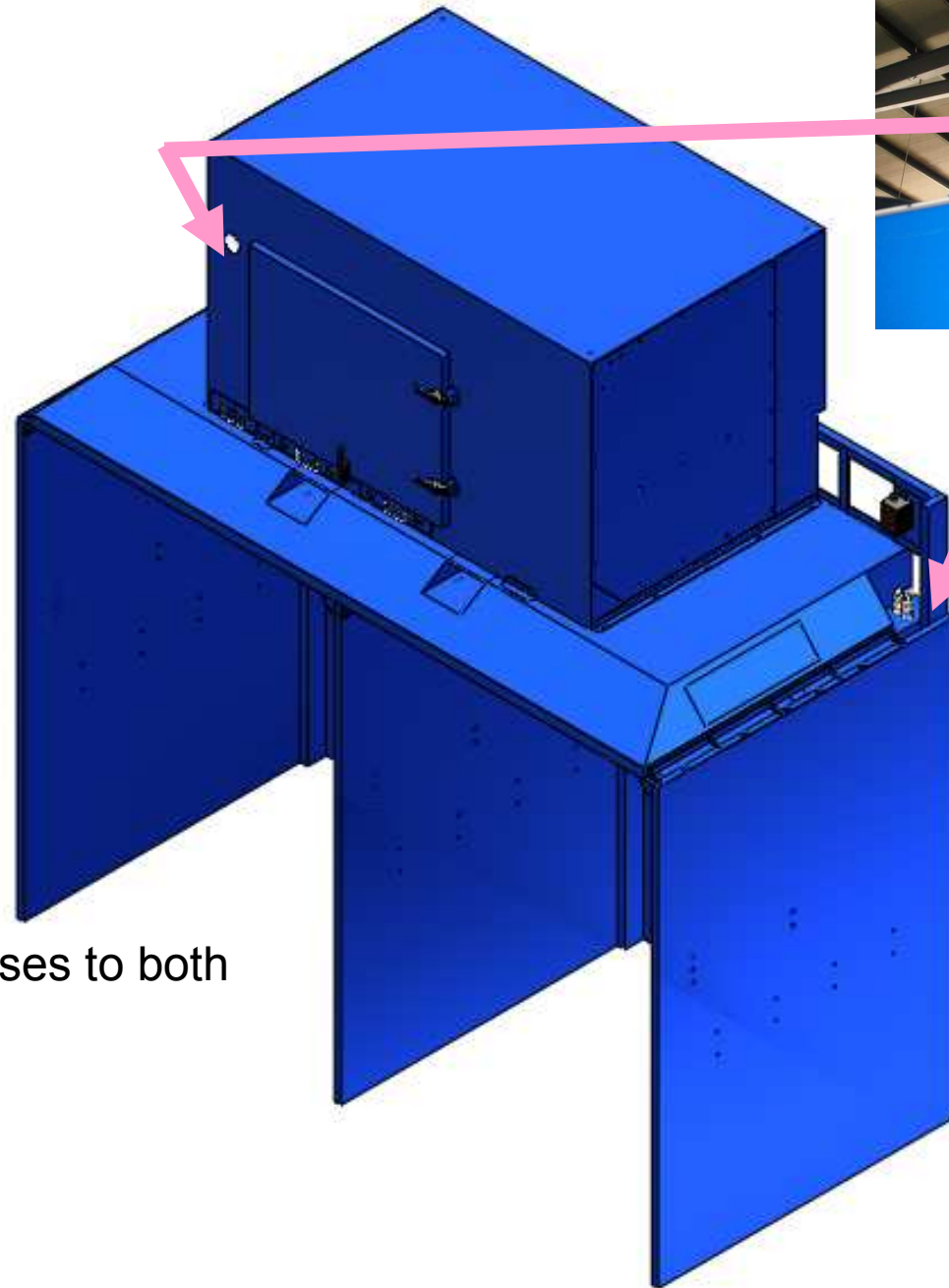

•Attach the fixing bases to both sides (pink arrows).

Hardware Bag A

Hardware Bag B

•Secure the adjustable backshelf in position, 1 pc in each booth, total 2 pcs for the two booths sitting together.

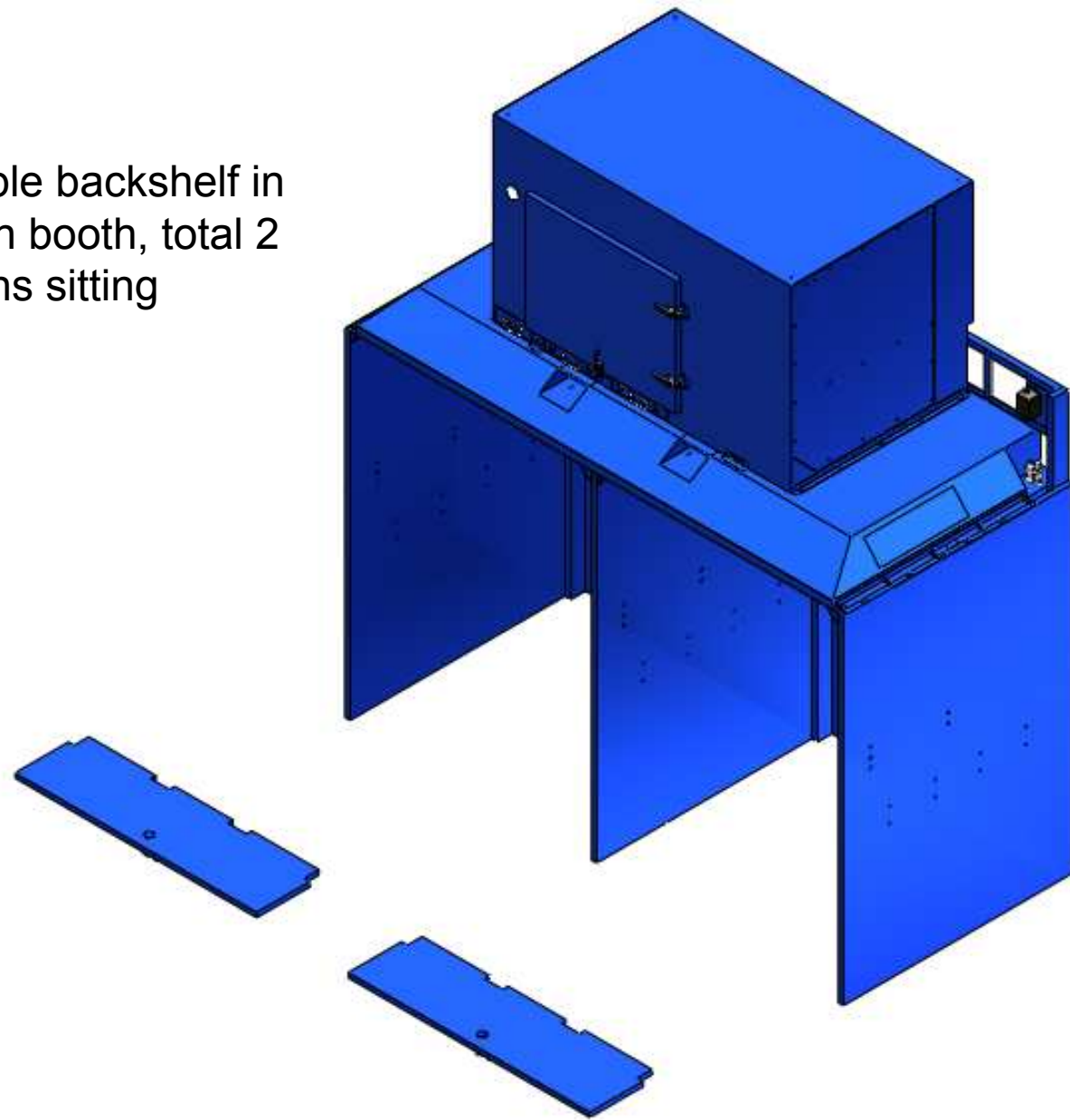

Hardware Bag F



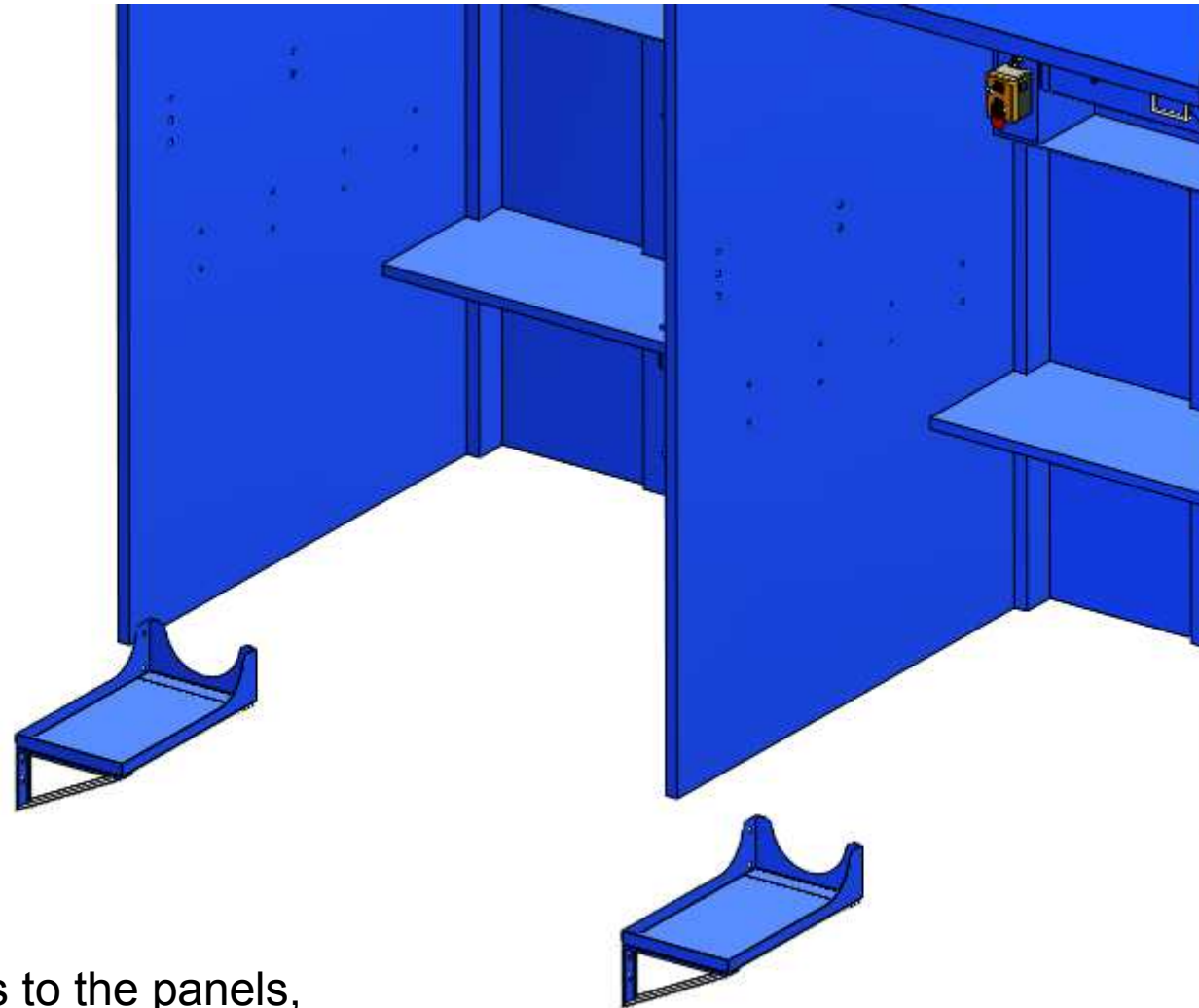

- Attach CO2 brackets to the panels, 1 pc in each booth, total 2 pcs for the two booths sitting together.

CO2 bracket

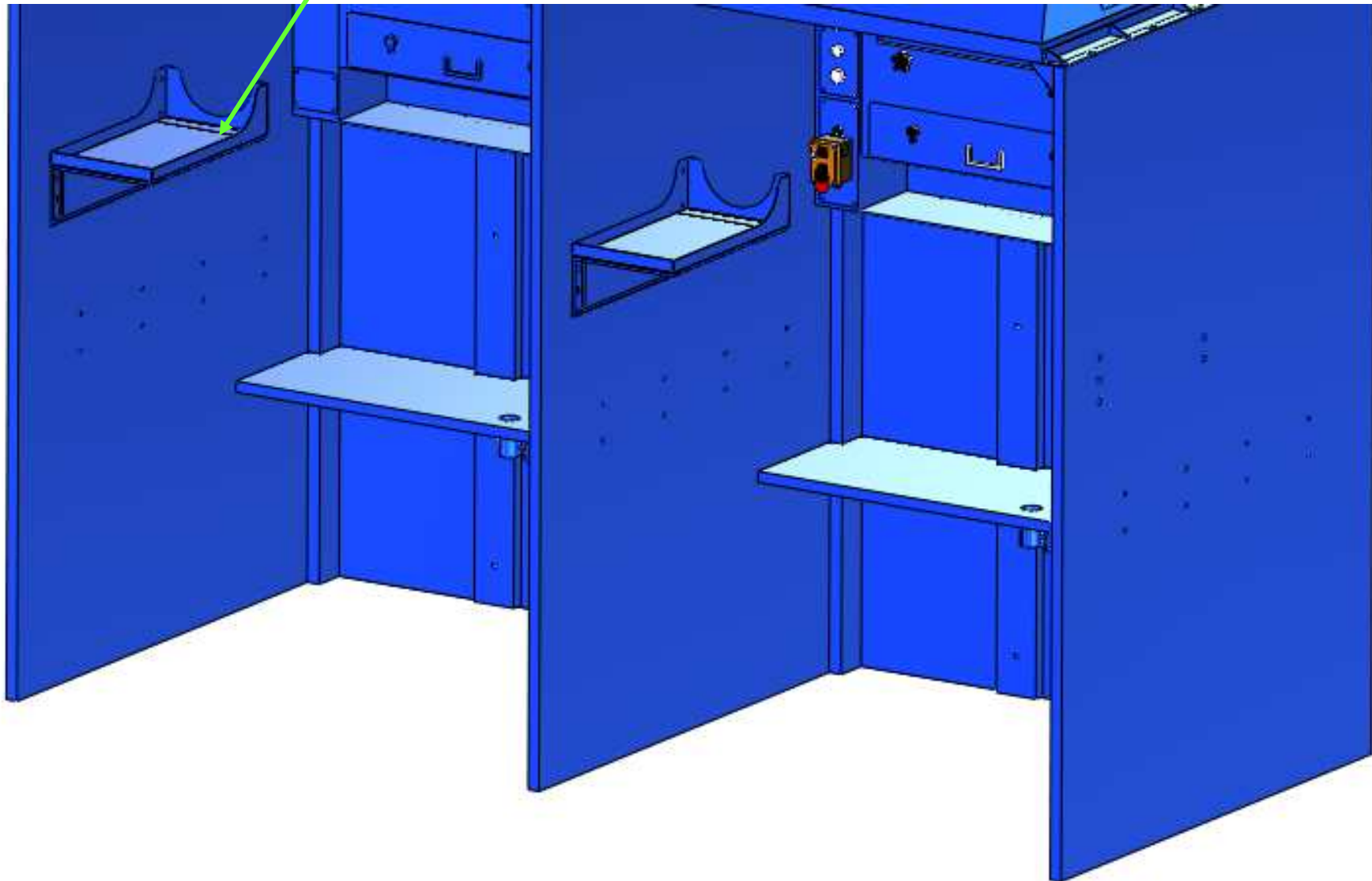

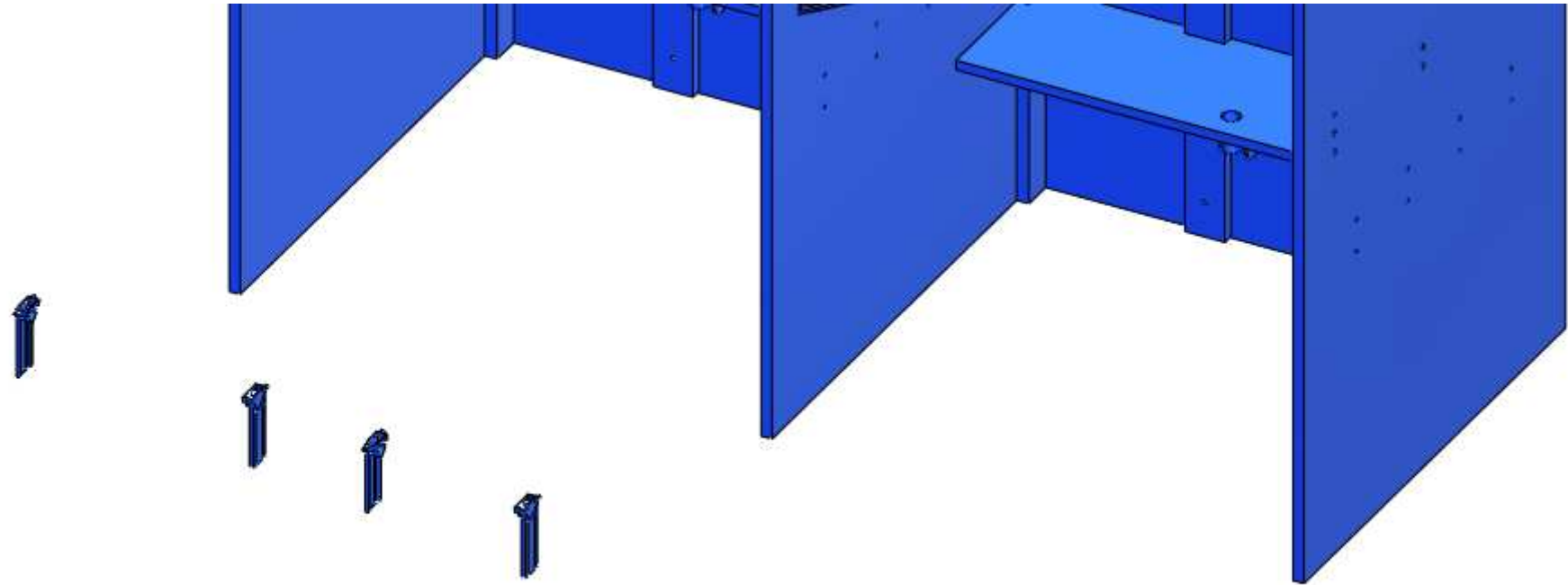

- Attach adjustable curtain rods to the side panels, 2 pcs in each booth, total 4 pcs for the two booths sitting together.

Hardware Bag O

adjustable curtain rod

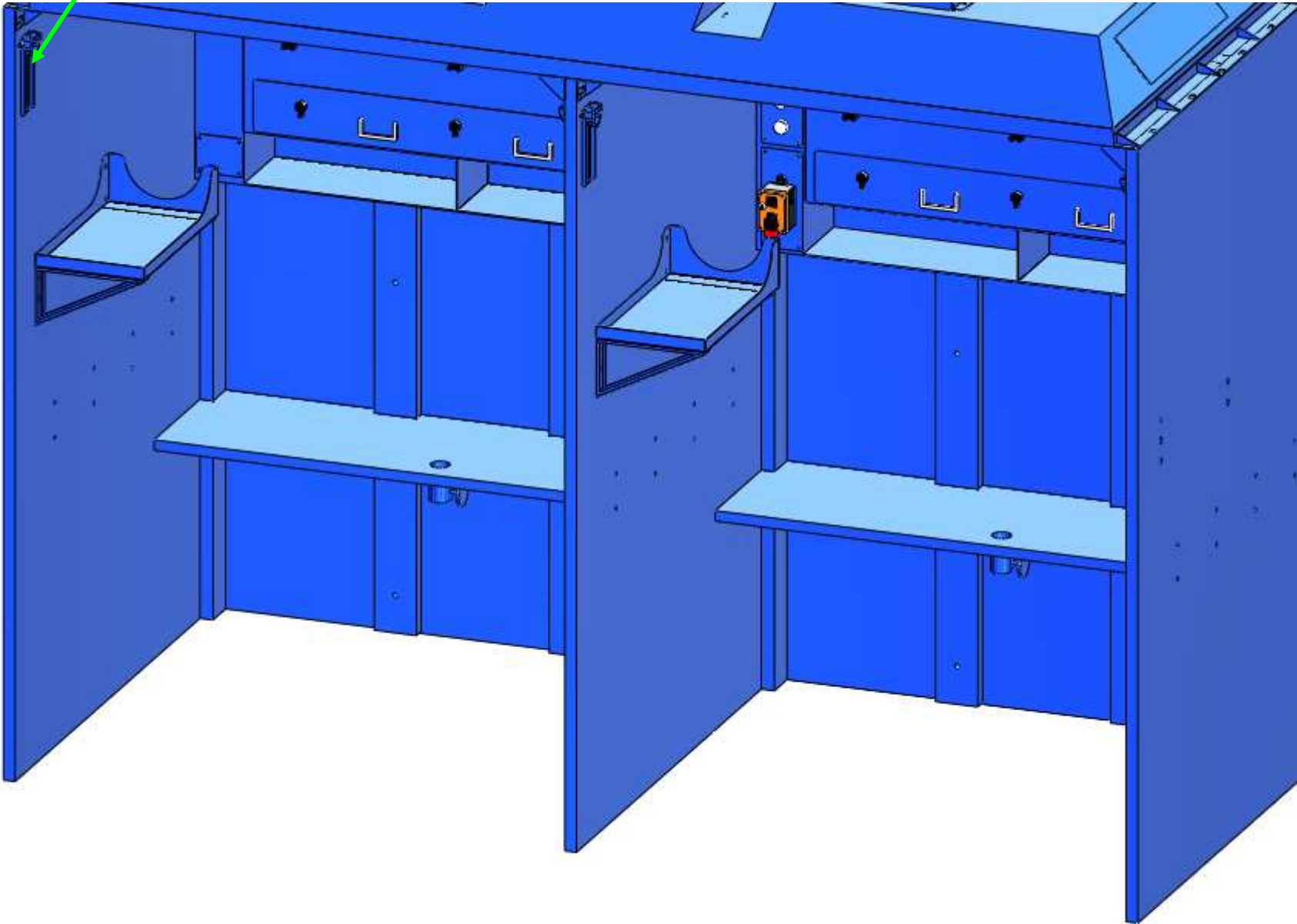

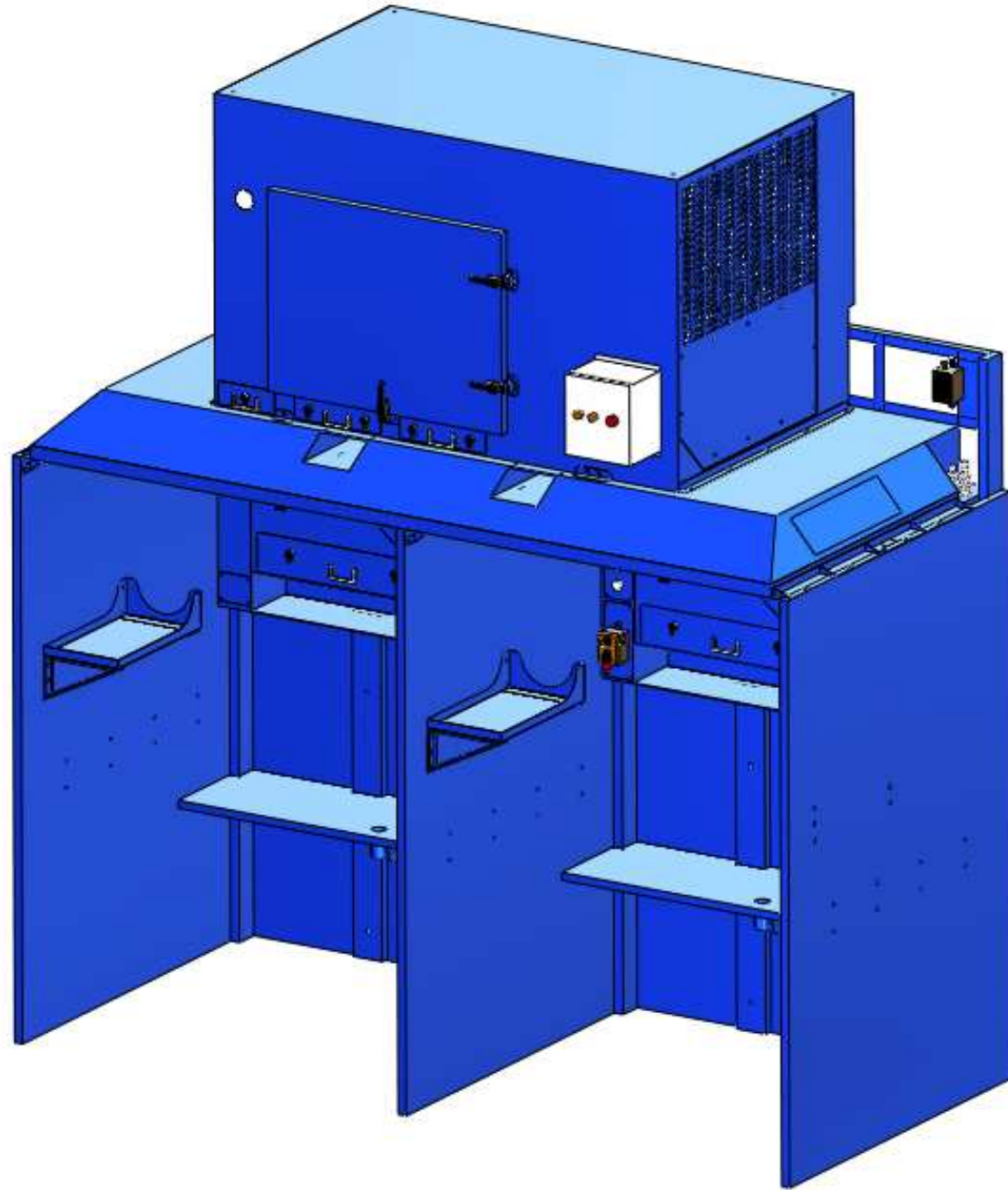

● WB-6055 (side-by-side):

- booth (4)
- 7.5HP top mount dust collectors (2)

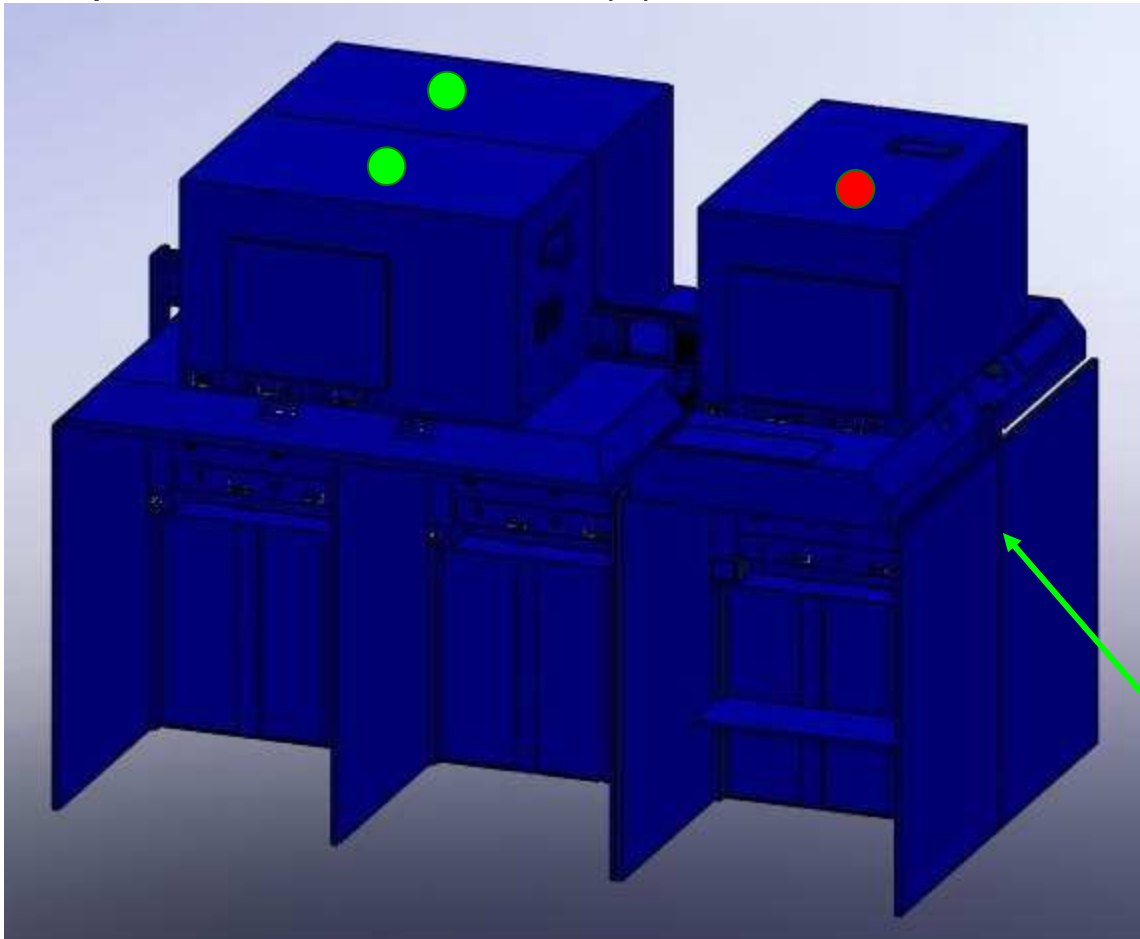

back to back connections

● WB-6055 (back-to-back):

- booth (2)
- 7.5HP top mount dust collectors (1)

Hardware Bag G



**D: control panels inside the booths**

**E: electrical junction box, cable connections of overhead lights and light switch**

**F: main power supply outsourcing for TMC-7-4**

**G: main electrical box wiring for TMC-7-4**

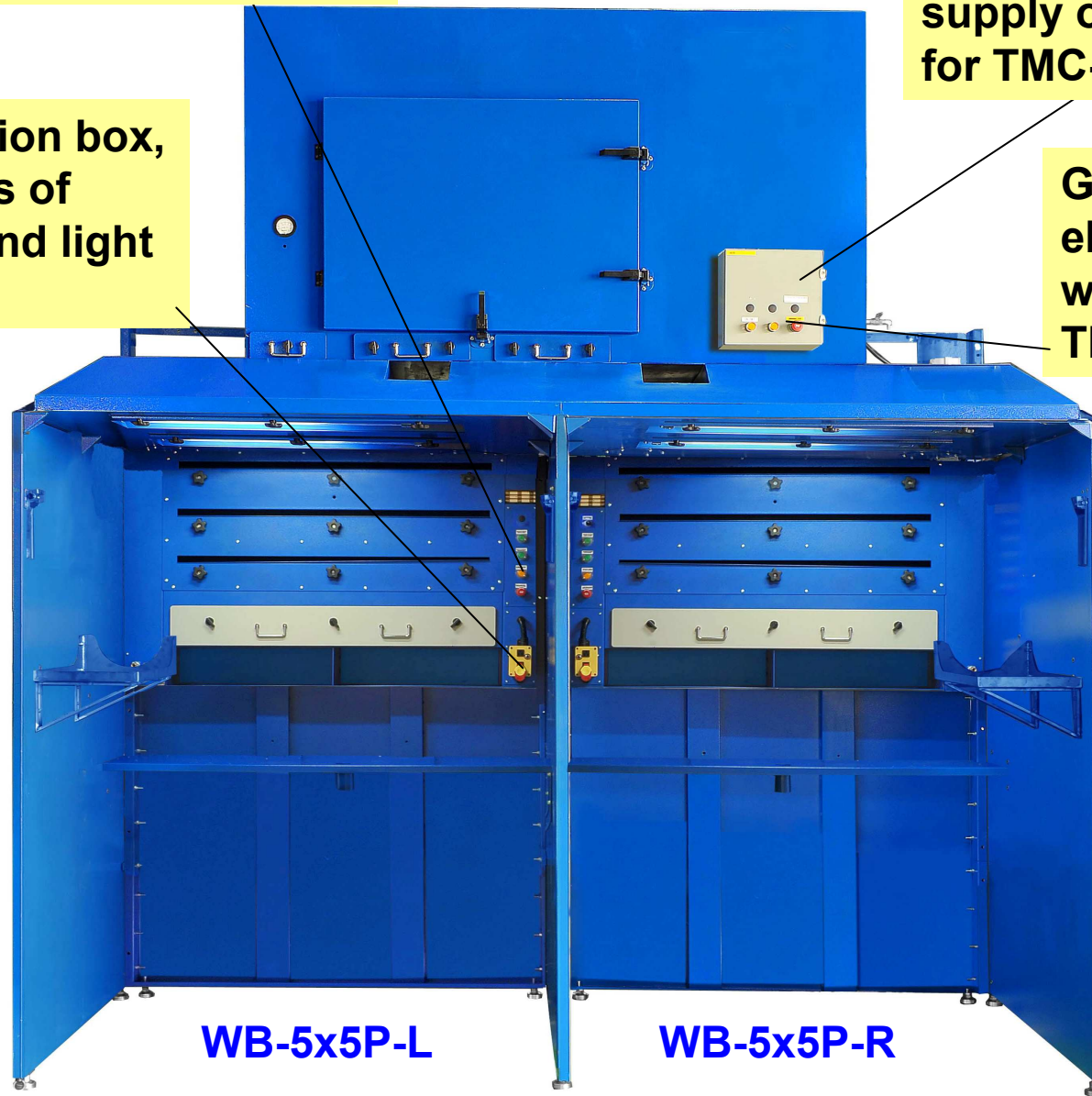

**WB-5x5P-L**

**WB-5x5P-R**

**(left booth when facing the unit)**

**(right booth when facing the unit)**

## D: control panels inside the booths







**D1: WB-5x5P-R control panel  
(right booth when facing the unit)**

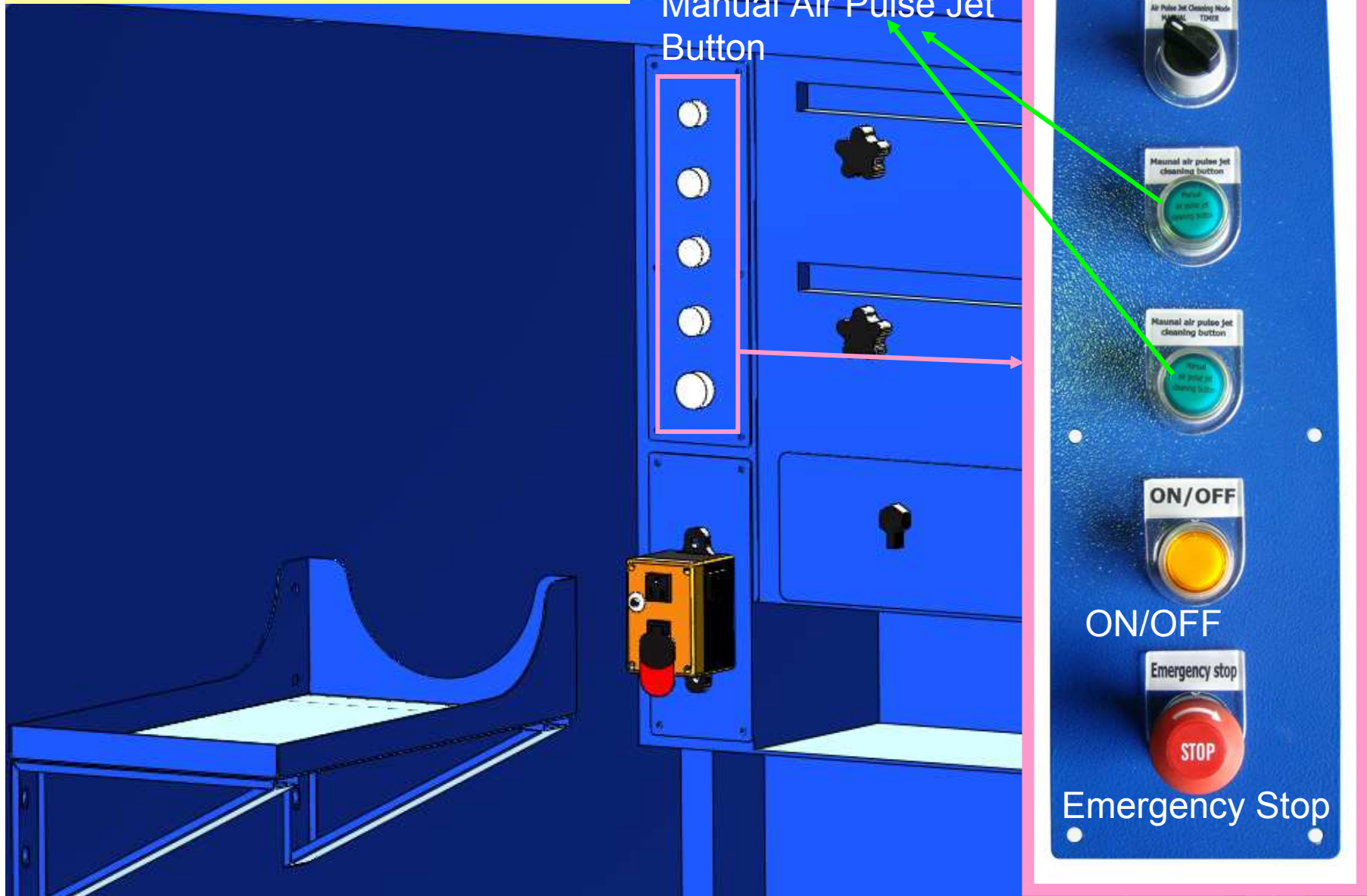

**D1: WB-5x5P-L control panel**  
**(left booth when facing the unit)**

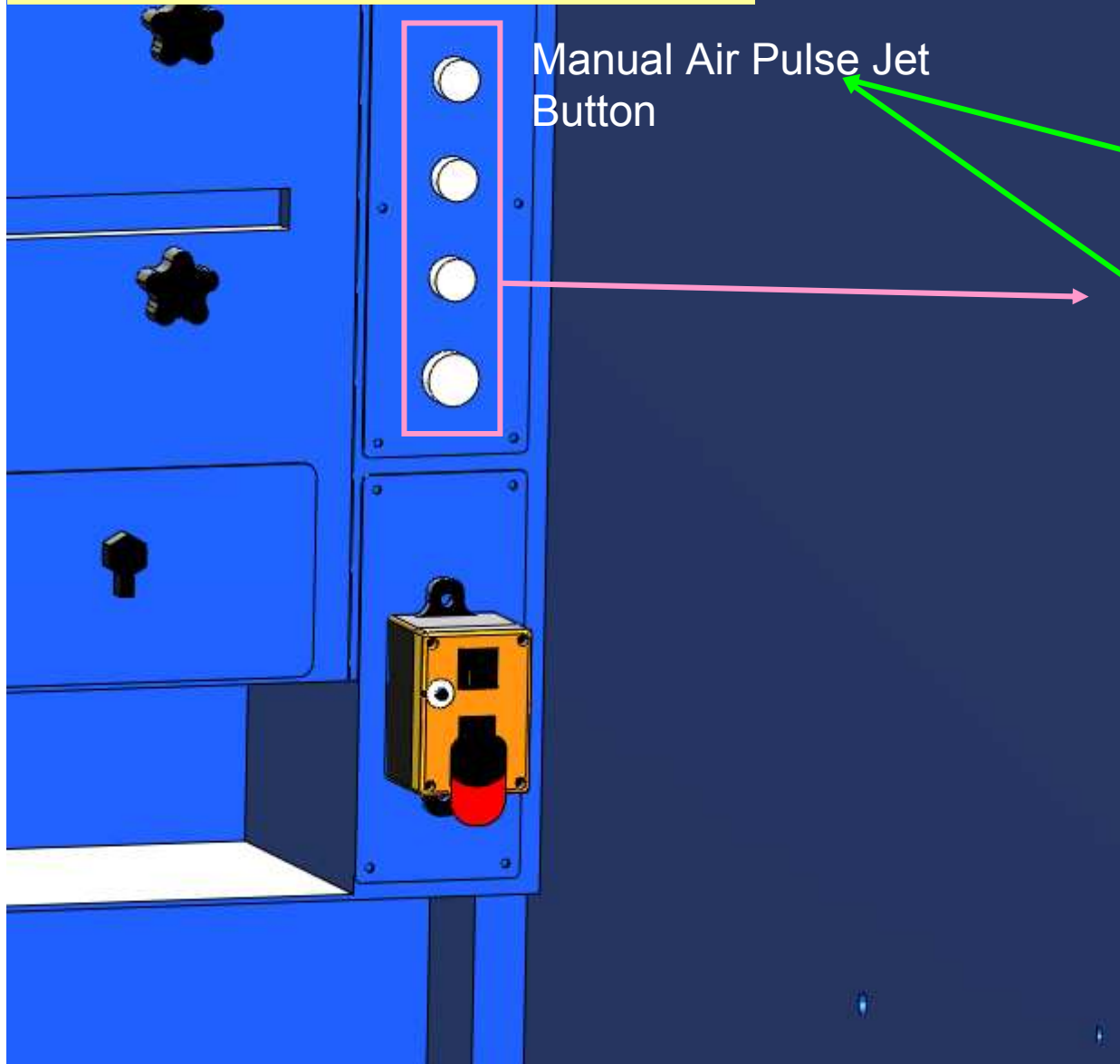

Manual Air Pulse Jet  
Button



Emergency Stop

## E: electrical junction box, cable connections of overhead lights and light switch



- ◆ Take out the light switch from packing.  
(number: 2 and 4)

- ◆ Put the light power cord into the hole.
- ◆ Have the light power cord go into the wireway blue circled and up through to booth top opening.

- ◆ Use the screwdriver to match the Philips Head Screw and lock the light switch on the booth.



- ◆ Take out the control panel from packing.  
(number: 1 and 3)

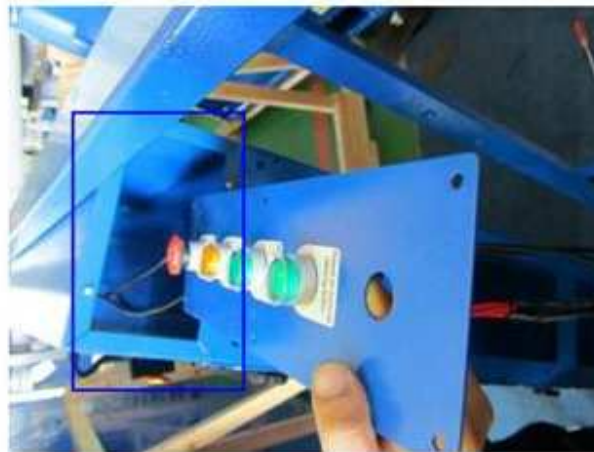

- ◆ Have the control panel go through the wireway and take out it from the wireway.



- ◆ Use the screwdriver to match the Philips Head Screw and lock the control panel on the booth.



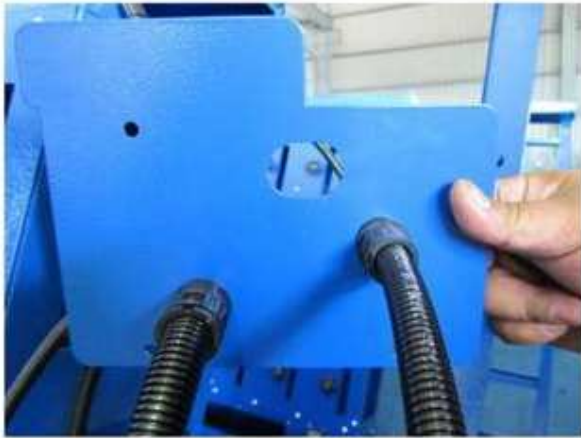

◆ Take out the iron plate from packing.



◆ Take out the corrugated plastic tubing from plastic connection.

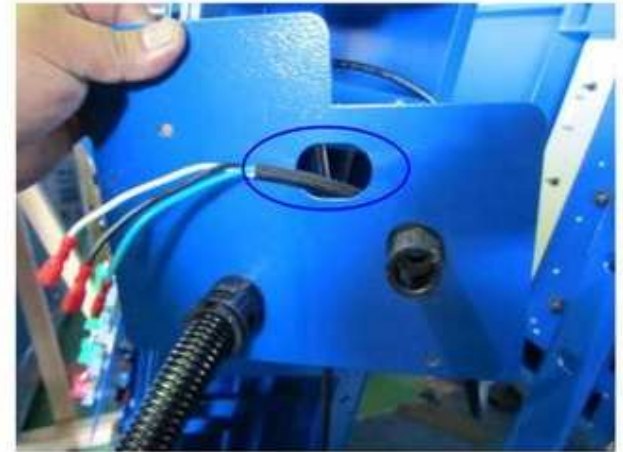

◆ Have the cord of the light switch go through the iron plate.



◆ Have the cord of light switch go through the plastic connection.



◆ Have the cord of light switch go through the plastic tubing.



◆ Lock the plastic tubing into the plastic connection.

## E1: cable connections of light switch to overhead lights for WB-5x5P



- ◆ Take out the cord of light from the steel adapter box.

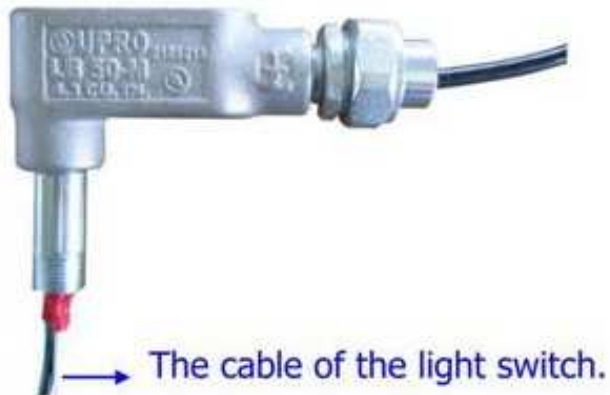

- ◆ Have the cord of the light switch go through the tube into the steel adapter box.

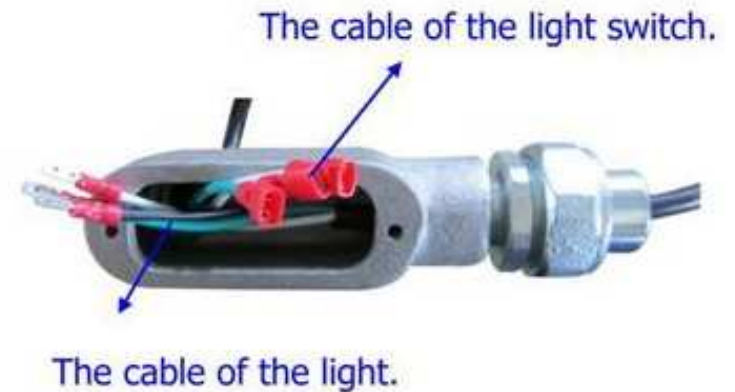

- ◆ Take out the cord of the light switch from the steel adapter box.

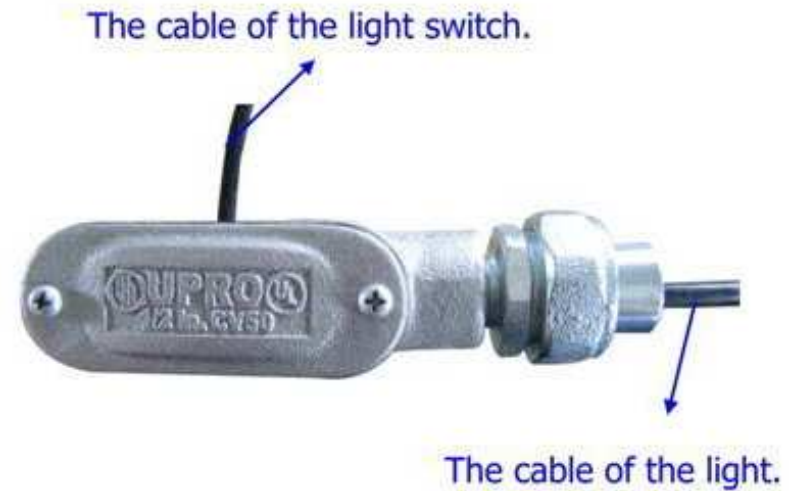
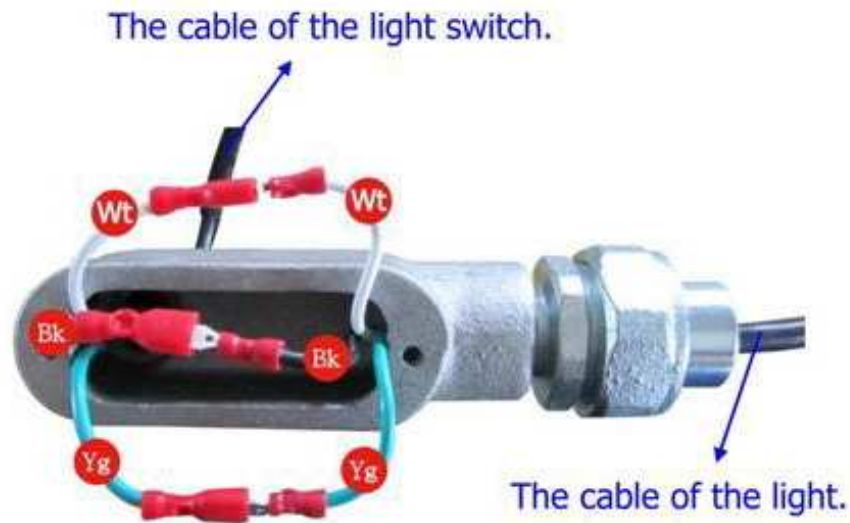

- ◆ Connection the white electrical wire with the white electrical wire.
- ◆ Connection the black electrical wire with the black electrical wire.
- ◆ Connection the green electrical wire with the green electrical wire.

- ◆ Lock the cover of the steel adapter box.



## E2: cable connections of electrical junction box for WB-5x5P



- ◆ Open the cover of the electrical junction box.



- ◆ Have the cable go through the plastic connection into the electrical junction box.



- ◆ Connection the cable with the terminal blocks for the electrical junction box.



- ◆ Have the cable go through the plastic connection into the electrical junction box.

Local main power supply coming in.



- ◆ Connection the cable with the terminal blocks for the electrical junction box.
- ◆ Link this set to local main power supply.



- ◆ Lock the cover of the electrical junction box.

**E3: wirings for light switch and 2-plugs sockets for WB-5x5P-L (left booth when facing the unit) and WB-5x5P-R (right booth when facing the unit)**

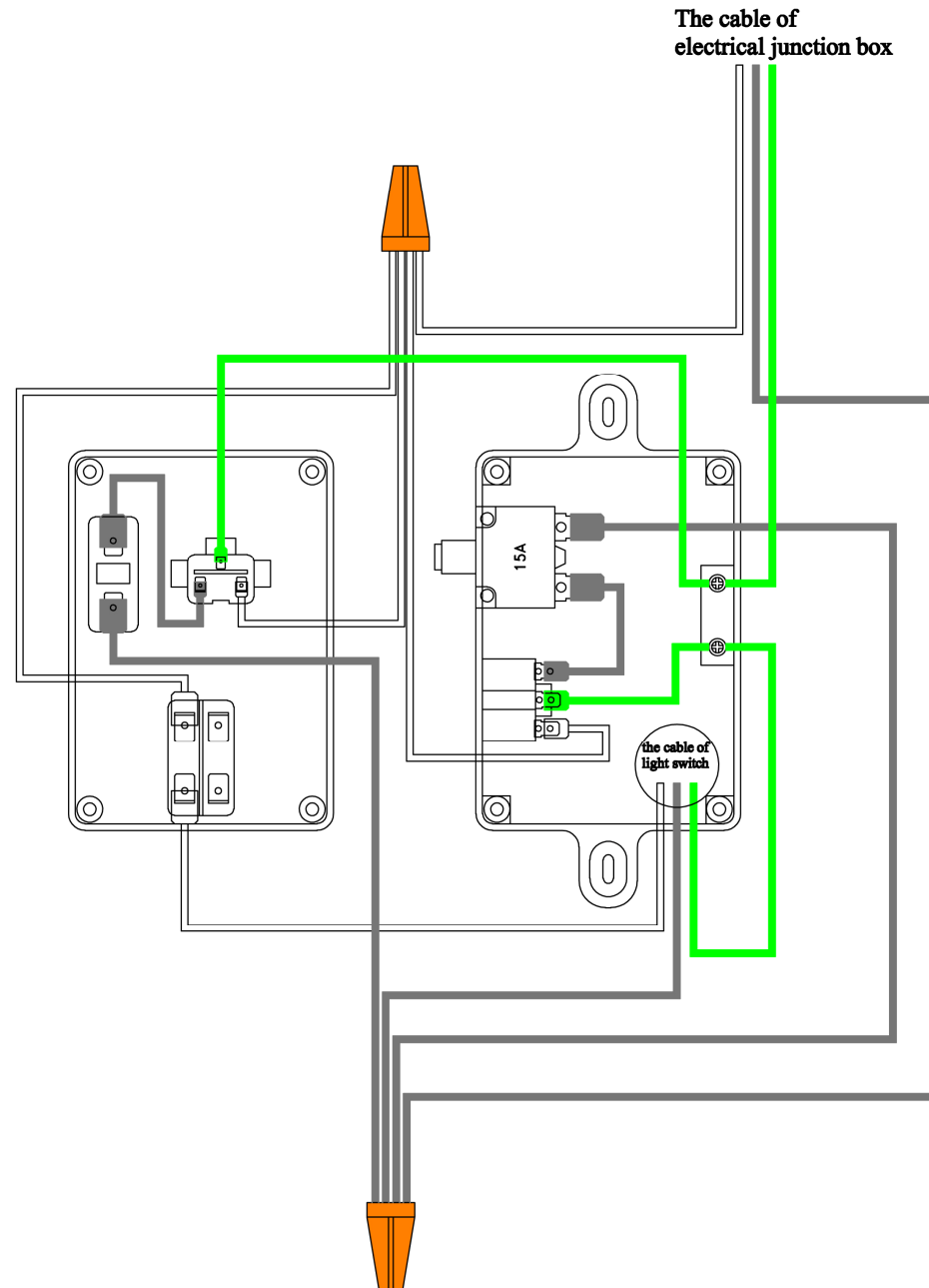



UL approved control box

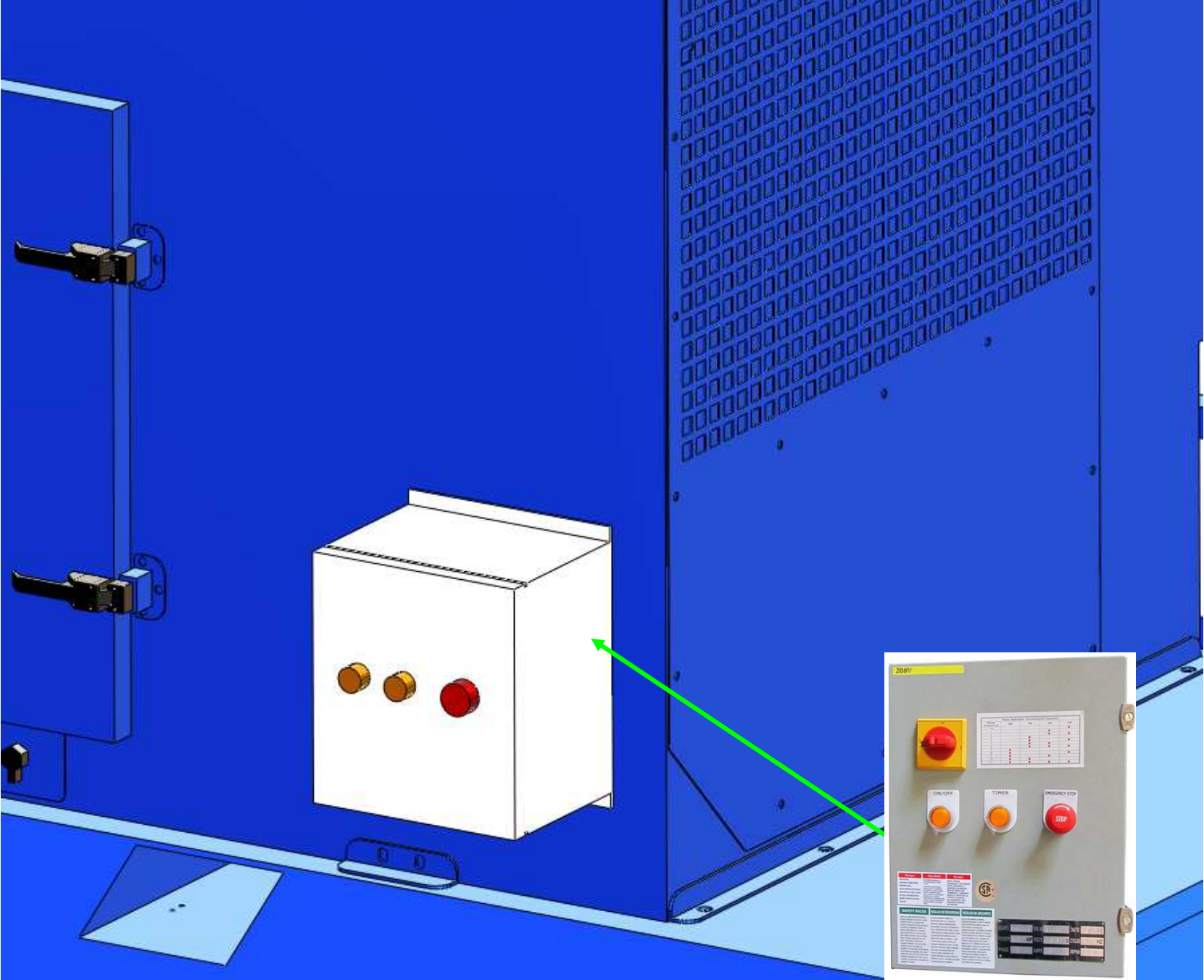

# F: main electrical box wiring for TMC-7-4

(control box: 7.5HP / 208/415V / 60Hz / 3Ph, **connected to 208V**)

## Main Electrical Box Wiring For TMC-7-4

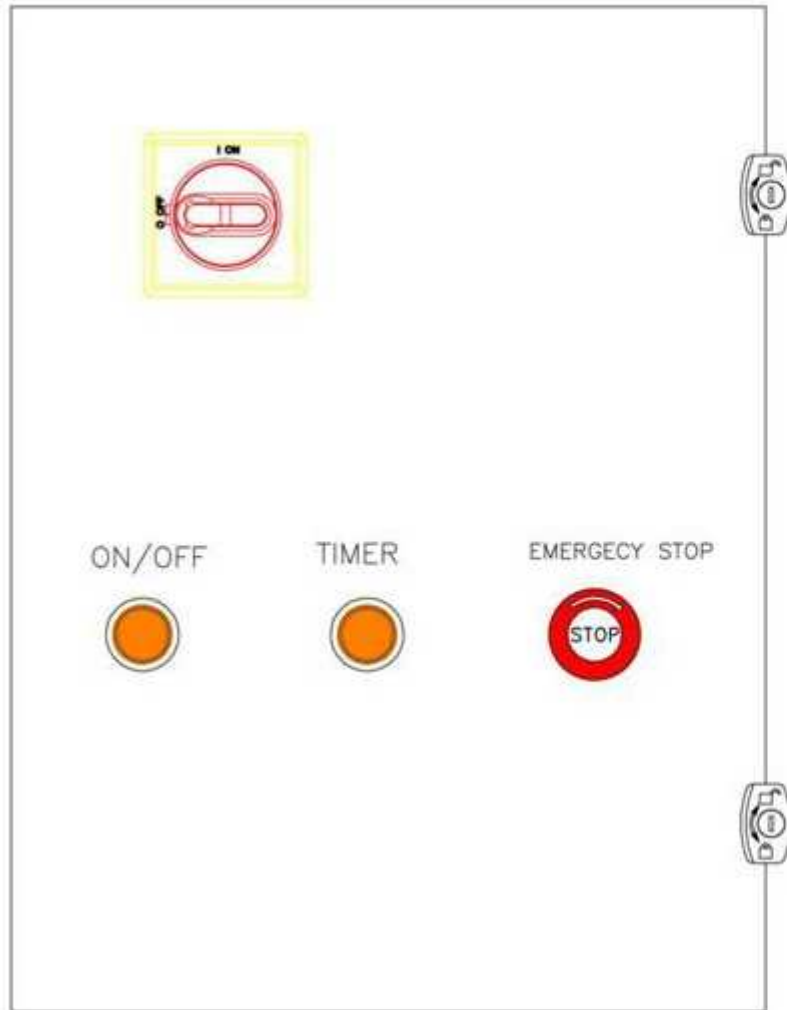

# Main Electrical Box Wiring For TMC-7-4

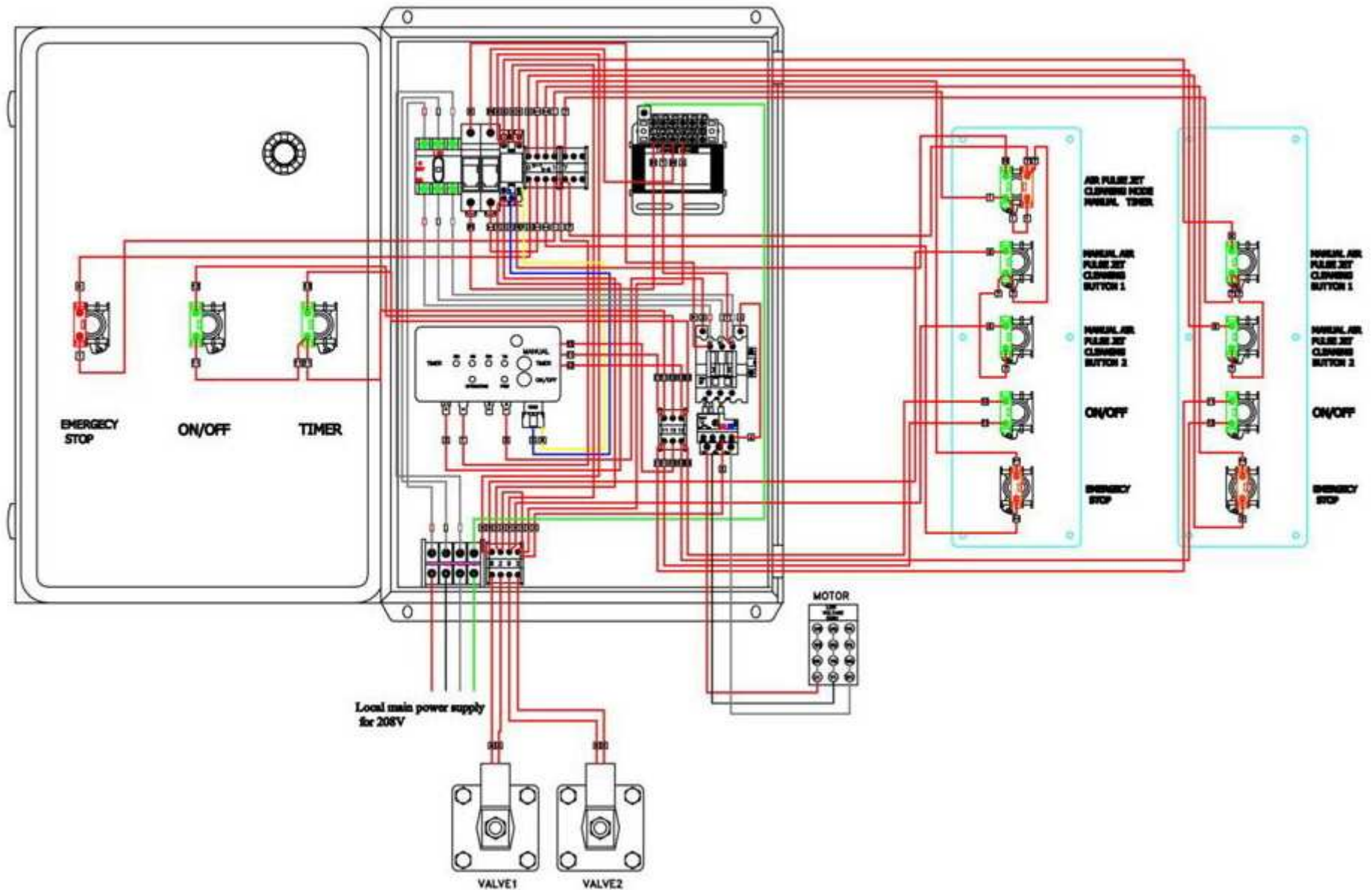

# Main Electrical Box Components for TMC-7-4

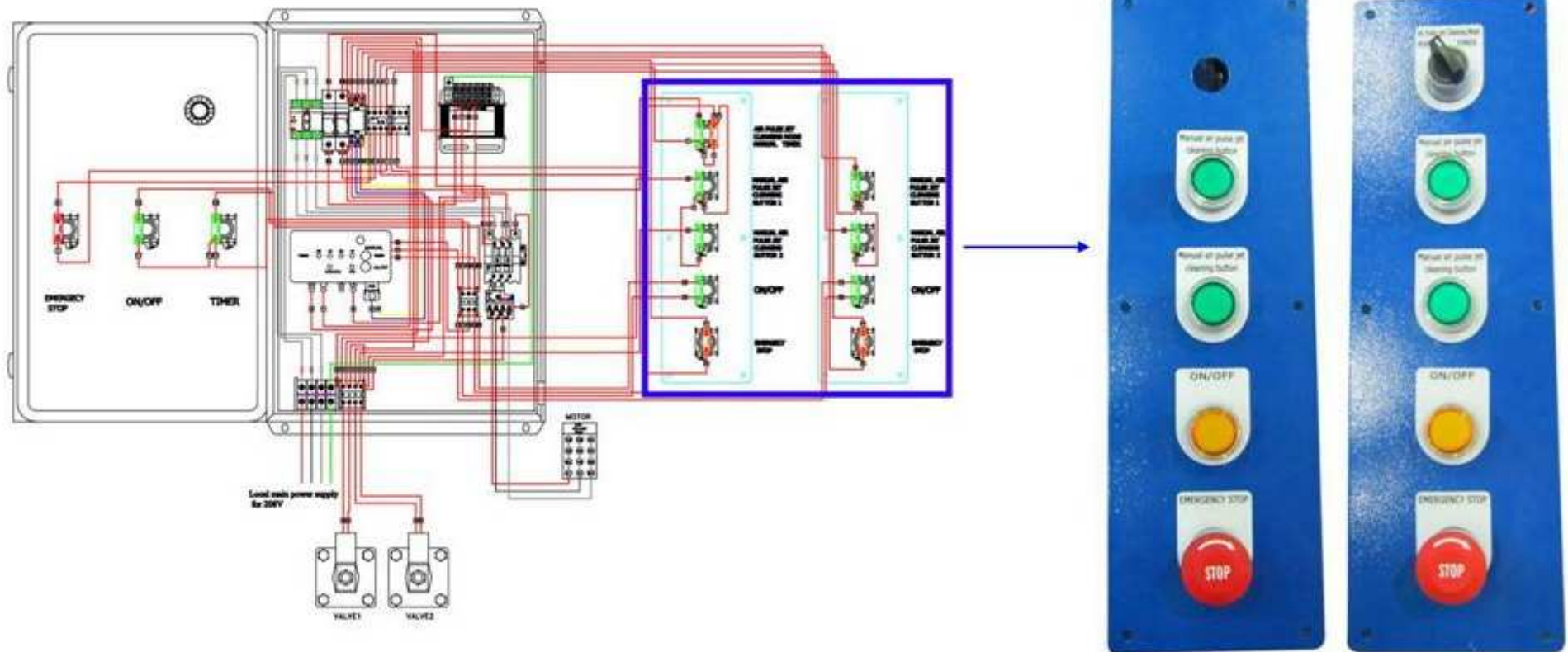



# Main Electrical Box Components for TMC-7-4



◆ IC Board (Front)



◆ IC Board (Back)

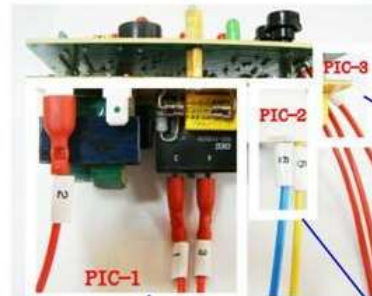

◆ 12 : TIMER.  
◆ 13 : ON/OFF

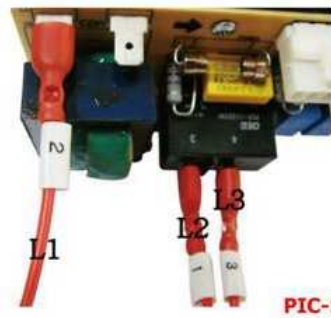

◆ L1/L2 : The main power.  
◆ L3 : The blower.

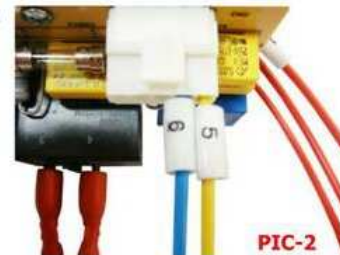

◆ Air pulse jet system.

# Main Electrical Box Components for TMC-7-4

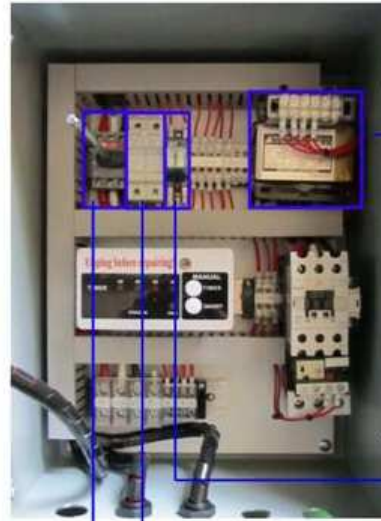

◆ Transformer for 208V.



◆ Panel disconnect switch.



◆ Fuse bus.



◆ Relay.





## Main Electrical Box Components for TMC-7-4

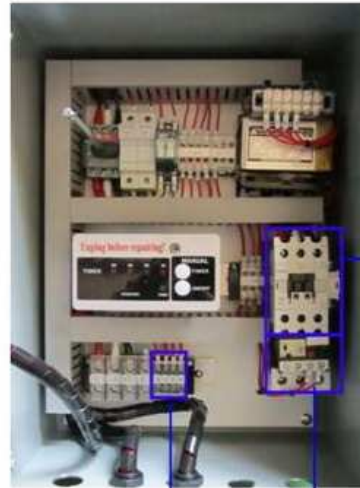

◆ Magnetic contactor.



◆ Air pulse jet system.



◆ Valve.



◆ Thermal Relay for motor of 7.5HP.



# Hardware bags detailed list:

Independent School TMC-7-4 above WB-6055 (dual booths side-by-side, total 2 sets)

A		Fixing Base (left)		# of pack required	2
	Part Name	Specification	Q'ty	Total	
1	Hex Screw	3/8"*2-1/2"	2	4	
2	Hex Screw	3/8"*3/4"	1	2	
3	Hex Screw	5/16"*3/4"	1	2	
4	Lock Nut	3/8"	2	4	
5	Flat Washer	3/8"*OD23*2t	5	10	
6	Flat Washer	5/16"*OD23*2t	1	2	

C		Right Side Panel to Main Set		# of pack required	2
	Part Name	Specification	Q'ty	Total	
1	Half-threaded Screw	3/8"*4"	8	16	
2	Lock Nut	3/8"	8	16	
3	Flat Washer	3/8"*OD23*2t	16	32	

E		Middle Panel to Main Set		# of pack required	2
	Part Name	Specification	Q'ty	Total	
1	Half-threaded Screw	3/8"*5-1/2"	10	20	
2	Lock Nut	3/8"	10	20	
3	Flat Washer	3/8"*OD23*2t	20	40	

K		Left Side Panel Top Joints		# of pack required	8
	Part Name	Specification	Q'ty	Total	
1	Hex Screw	5/16"*3/4"	2	16	
2	Flat Washer	5/16"*OD23*2t	2	16	

O		Curtain Rod		# of pack required	8
	Part Name	Specification	Q'ty	Total	
1	Hex Screw	1/4"*3/4"	4	32	
2	Flat Washer	1/4"*OD19*2t	4	32	

S		Adjacence of the Top Hood Draft (back part) and Upper Part of the Backdraft Module - 2		# of pack required	2
	Part Name	Specification	Q'ty	Total	
1	Hex Screw	5/16"*3/4"	10	20	
2	Flat Washer	5/16"*OD23*2t	10	20	

V		CO2 Bracket		# of pack required	4
	Part Name	Specification	Q'ty	Total	
1	Hex Screw	5/16"*3/4"	7	28	
2	Flat Washer	5/16"*OD23*2t	7	28	

G		Hardware for Backdraft & Back Panels Back-to-Back Connections		# of pack required	1
	Part Name	Specification	Q'ty	Total	
1	Half-threaded Screw	3/8"*9"	12	12	
2	Lock Nut	3/8"	12	12	
3	Flat Washer	3/8"*OD23*2t	24	24	

B		Fixing Base (right)		# of pack required	2
	Part Name	Specification	Q'ty	Total	
1	Hex Screw	3/8"*2-1/2"	2	4	
2	Hex Screw	3/8"*3/4"	1	2	
3	Hex Screw	5/16"*3/4"	1	2	
4	Lock Nut	3/8"	2	4	
5	Flat Washer	3/8"*OD23*2t	5	10	
6	Flat Washer	5/16"*OD23*2t	1	2	

D		Left Side Panel to Main Set		# of pack required	2
	Part Name	Specification	Q'ty	Total	
1	Half-threaded Screw	3/8"*4"	8	16	
2	Lock Nut	3/8"	8	16	
3	Flat Washer	3/8"*OD23*2t	16	32	

F		Adjustable Backshelf (solid)		# of pack required	4
	Part Name	Specification	Q'ty	Total	
1	Hex Screw	5/16"*3/4"	8	32	
2	Flat Washer	5/16"*OD18*2t	8	32	

M		Right Side Panel Top Joints		# of pack required	8
	Part Name	Specification	Q'ty	Total	
1	Hex Screw	5/16"*3/4"	2	16	
2	Flat Washer	5/16"*OD23*2t	2	16	

R		Adjacence of the Top Hood Draft (back part) and Upper Part of the Backdraft Module - 1		# of pack required	2
	Part Name	Specification	Q'ty	Total	
1	Hex Screw	5/16"*3/4"	38	76	
2	Hex Nut	5/16"	38	76	
3	Flat Washer	5/16"*OD23*2t	76	152	

T		Adjacence of the Top Hood Draft (back part) and Upper Part of the Backdraft Module - 3		# of pack required	2
	Part Name	Specification	Q'ty	Total	
1	Hex Screw	5/16"*3/4"	35	70	
2	Flat Washer	5/16"*OD23*2t	35	70	

X		Adjacence of the Upper Part of the Backdraft Module		# of pack required	2
	Part Name	Specification	Q'ty	Total	
1	Hex Screw	5/16"*3/4"	24	48	
2	Flat Washer	5/16"*OD23*2t	24	48	