

✚ Installations for WB-1066 (4 booths side by side).

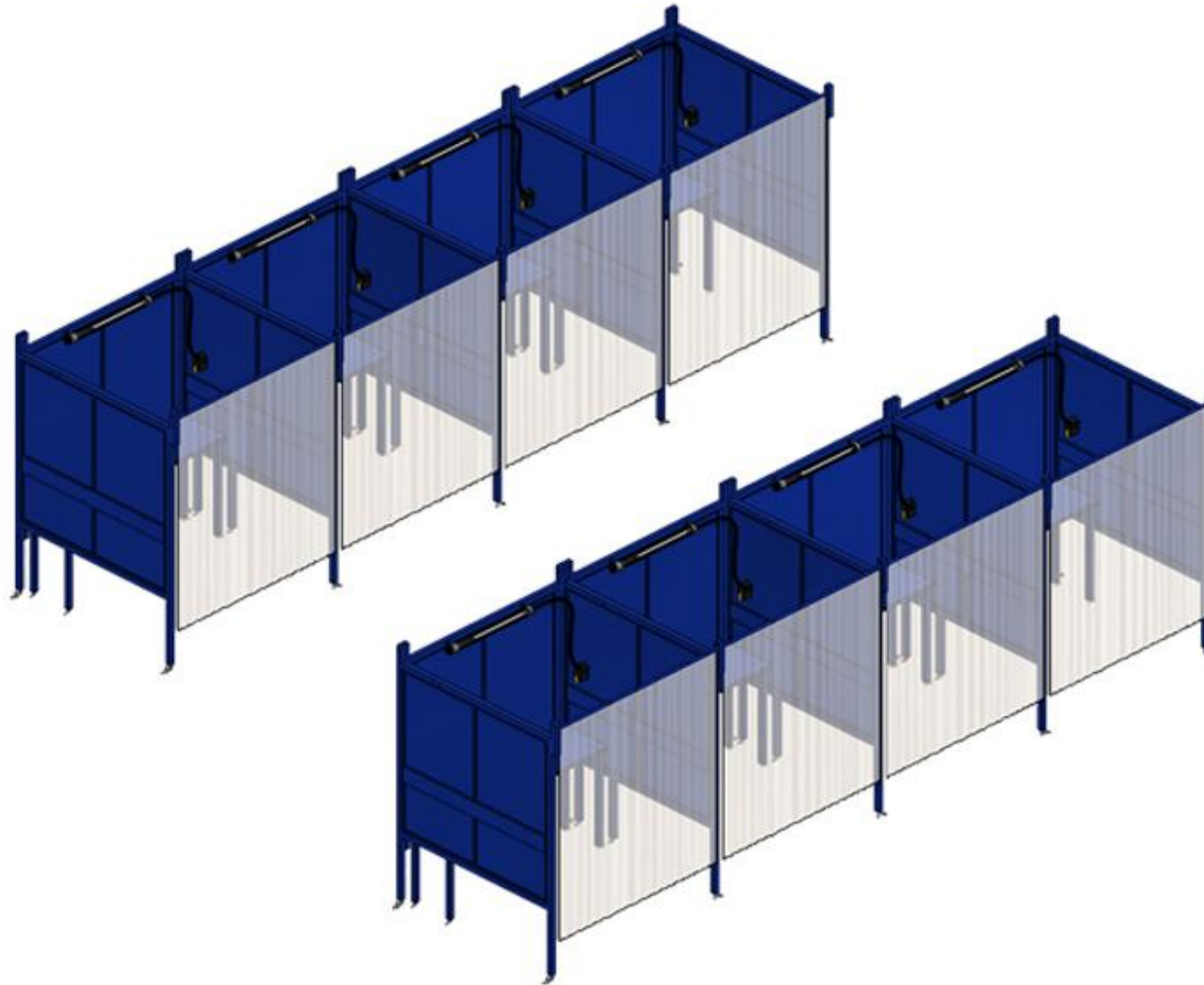

✚ Installations for WB-1066 (4 booths side by side).

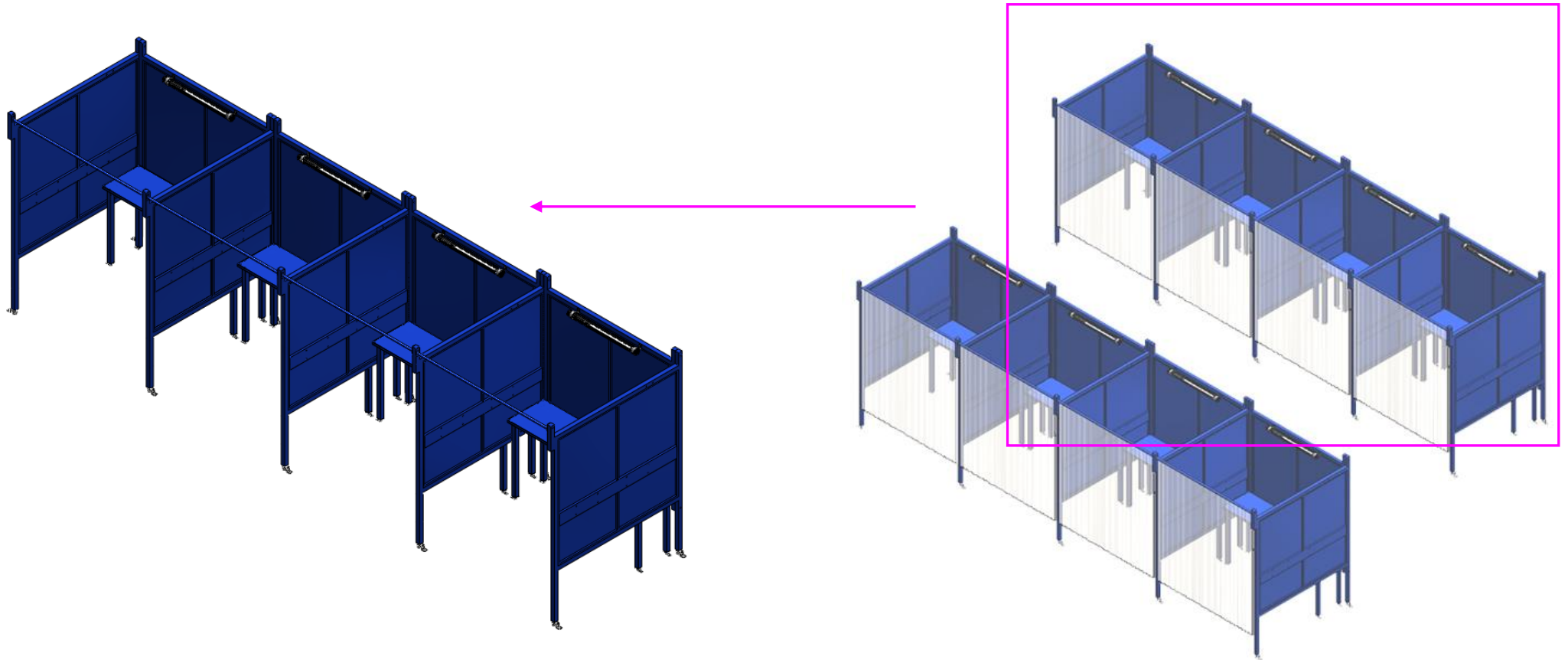

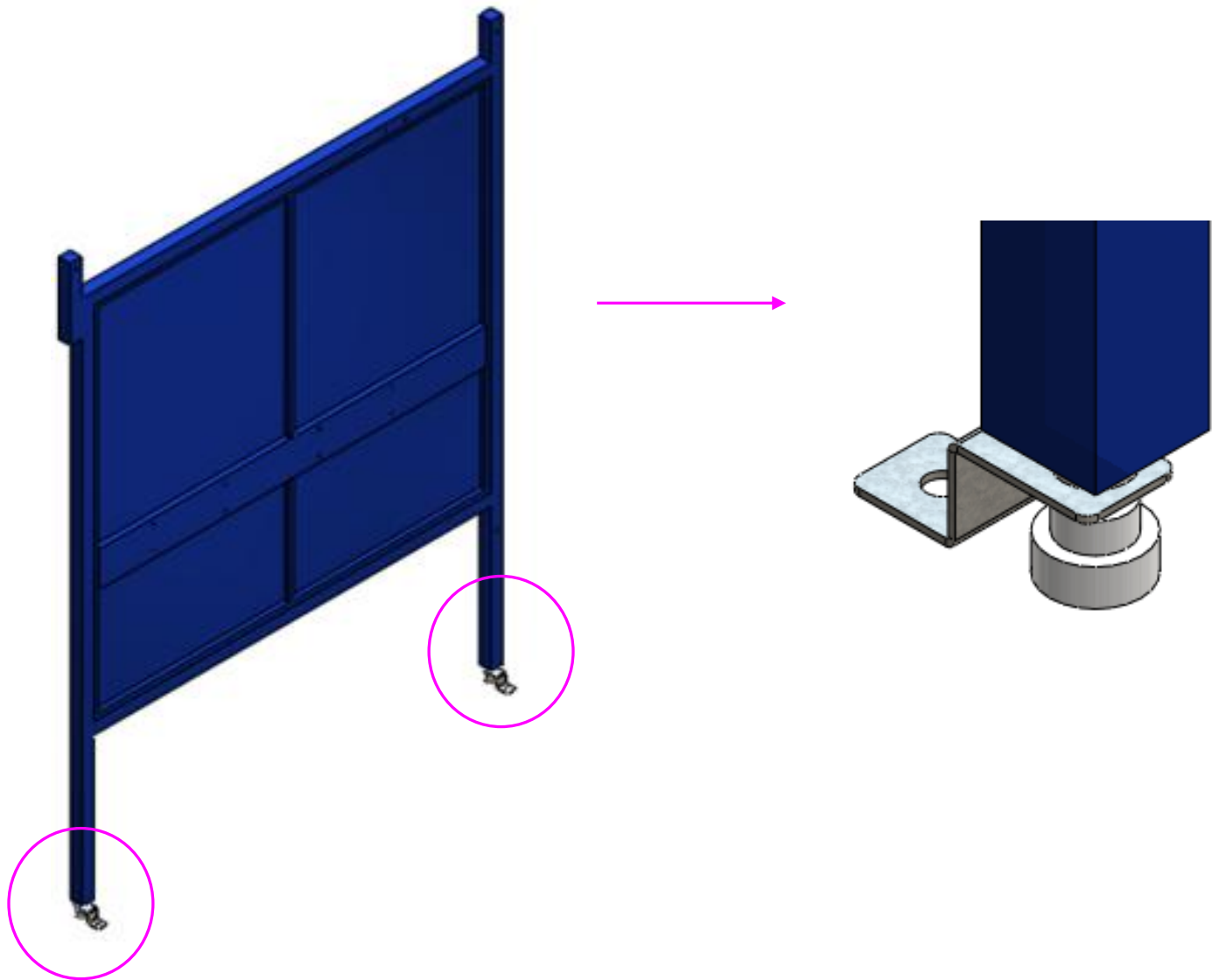

✦ Installations for WB-1066 (4 booths side by side).

- Take out **Adjustable Feet**.
- Fasten **Adjustable Feet** to **BL, BM-1~3 and BR**.

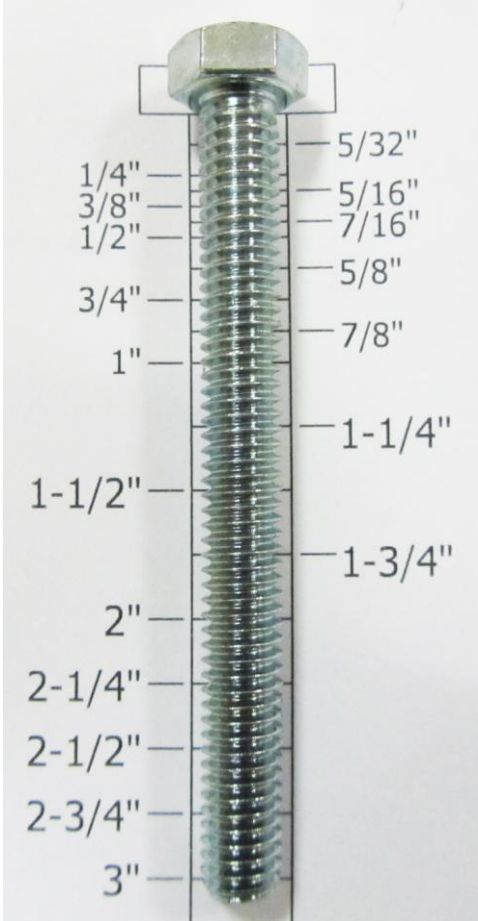

✚ Installations for WB-1066 (4 booths side by side).

- Take out **BL** and **BS-1**.
- Join **BL** and **BS-1** together with:

Part name	Description	Photos	Q'ty	Grainger Model #
Hex Screw	5/16" x 3"		2	1YU39
Flat Washer	5/16" x OD23 x 2T		2	*1JY31

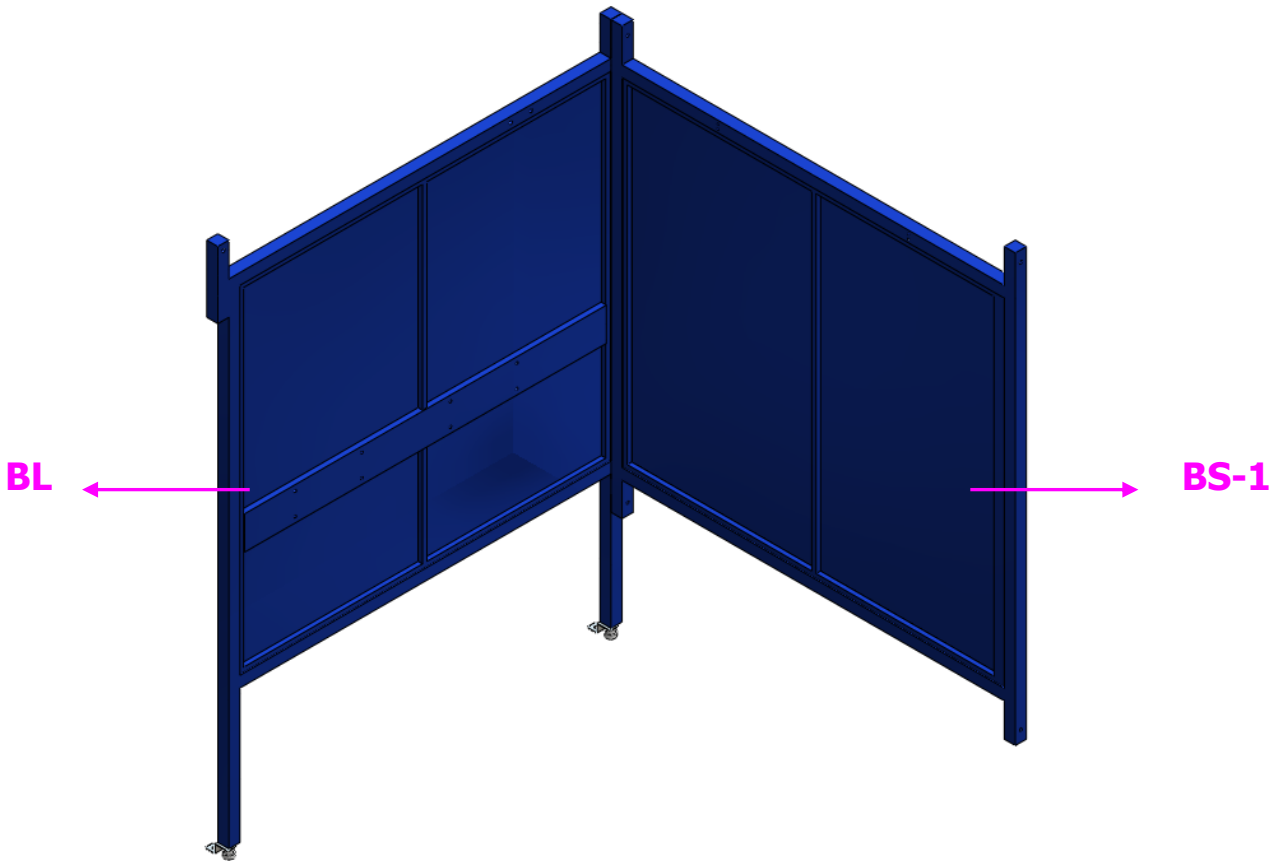
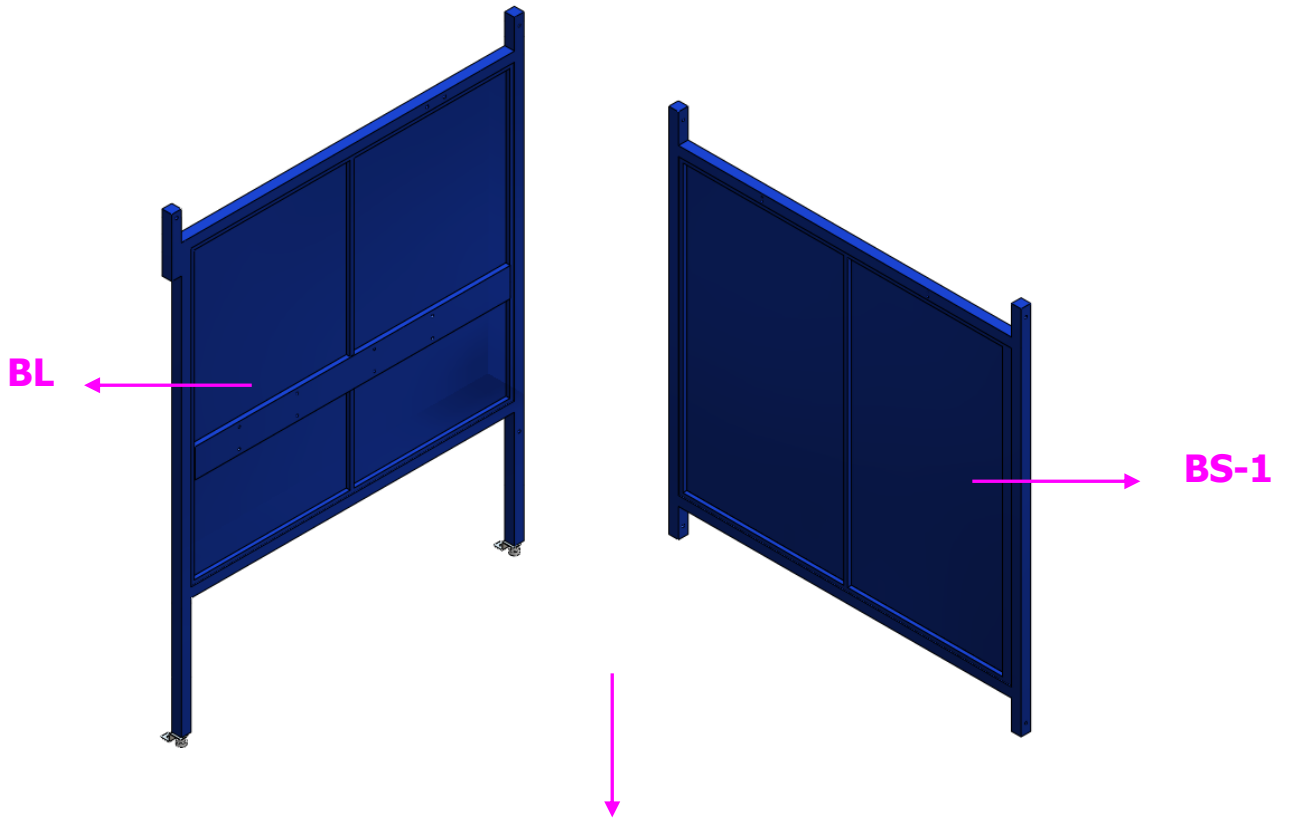

(* Hardware item at similar spec available locally.

✦ Installations for WB-1066 (4 booths side by side).

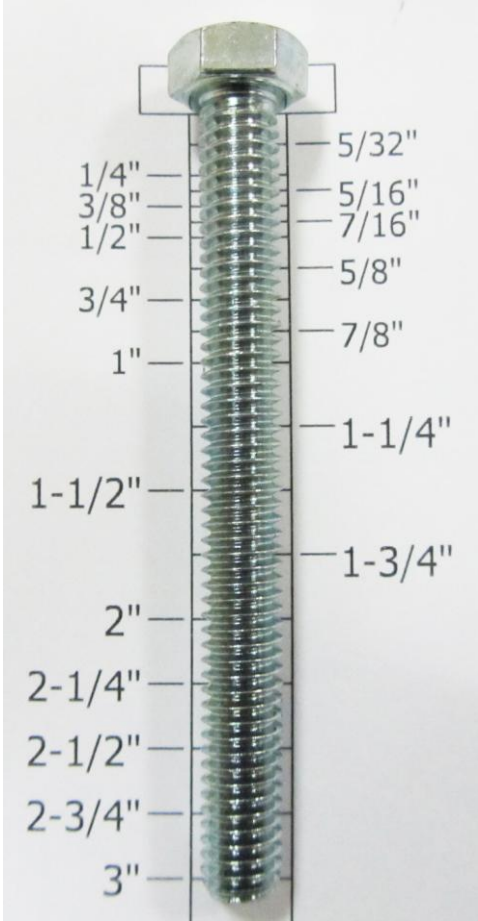

✚ Installations for WB-1066 (4 booths side by side).

- Take out **BM-1**.
- Fasten **BM-1** to **BS-1** with:

Part name	Description	Photos	Q'ty	Grainger Model #
Hex Screw	5/16" x 3"		2	1YU39
Flat Washer	5/16" x OD23 x 2T		2	*1JY31

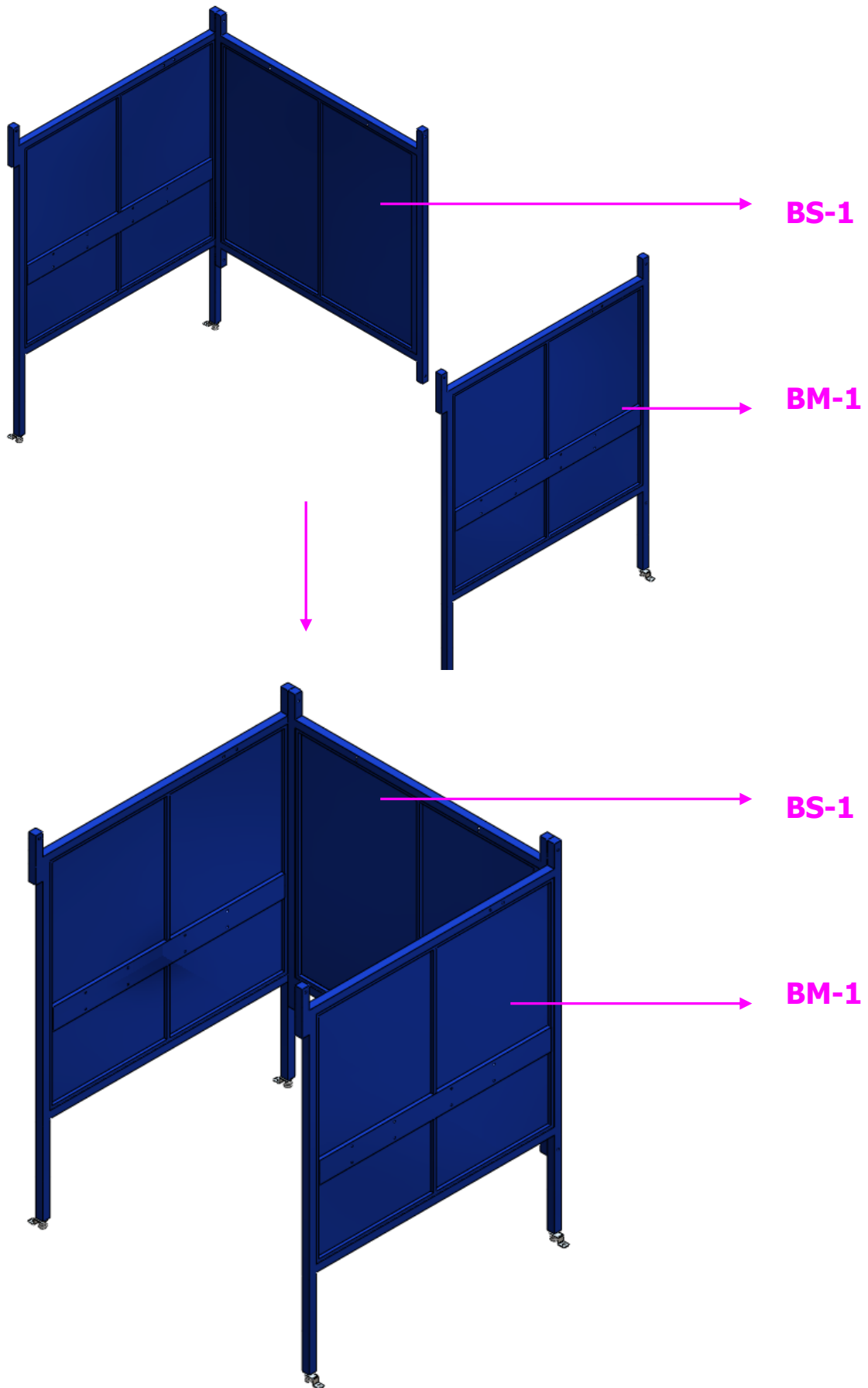

(* Hardware item at similar spec available locally.

✦ Installations for WB-1066 (4 booths side by side).

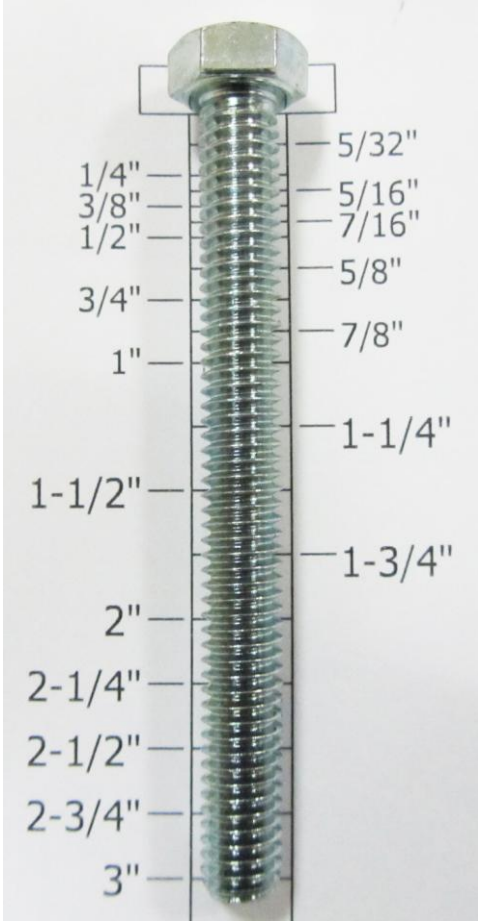

✚ Installations for WB-1066 (4 booths side by side).

- Take out **BS-2**.
- Fasten **BS-2** to **BM-1** with:

Part name	Description	Photos	Q'ty	Grainger Model #
Hex Screw	5/16" x 3"		2	1YU39
Flat Washer	5/16" x OD23 x 2T		2	*1JY31

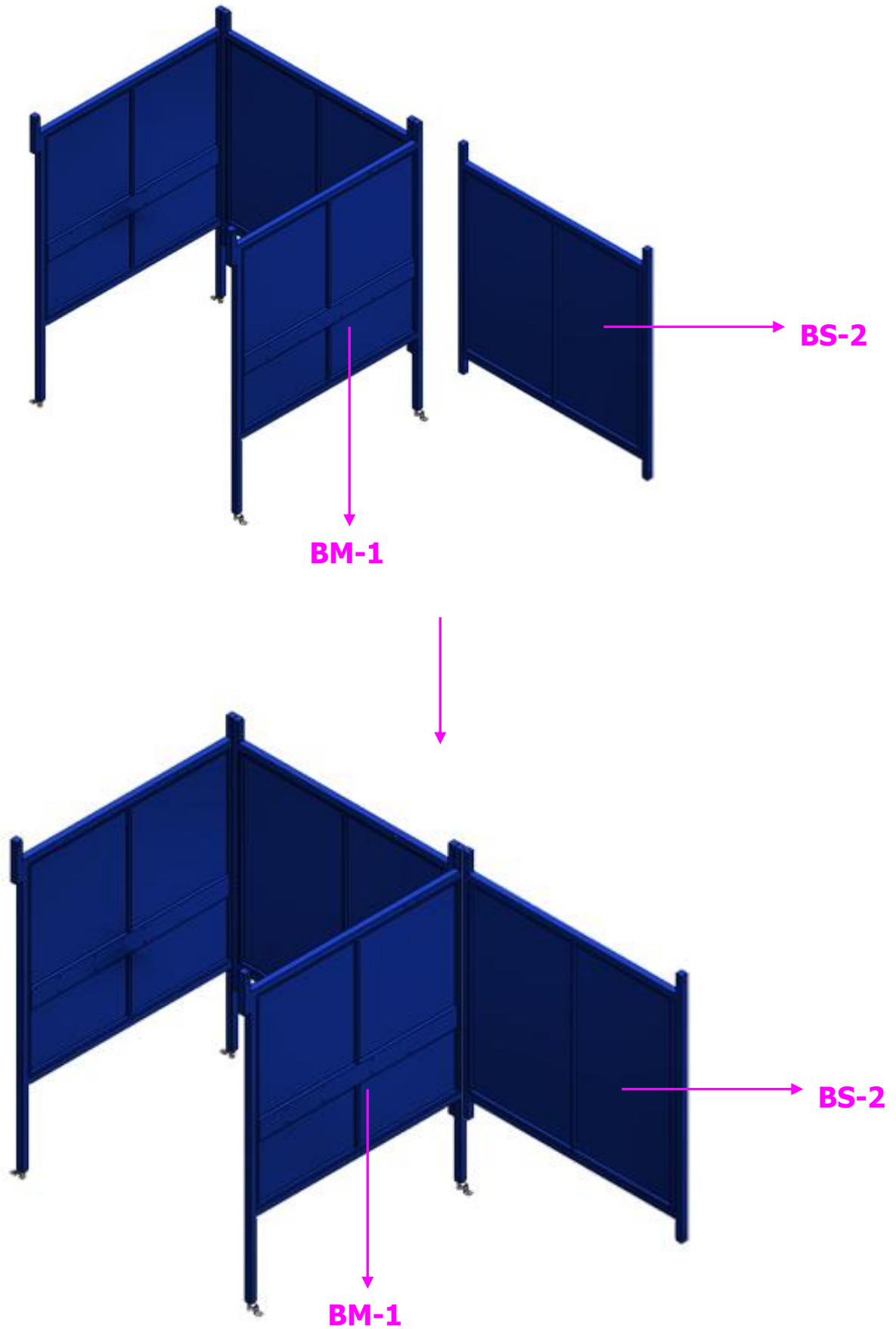

(* Hardware item at similar spec available locally.

✦ Installations for WB-1066 (4 booths side by side).

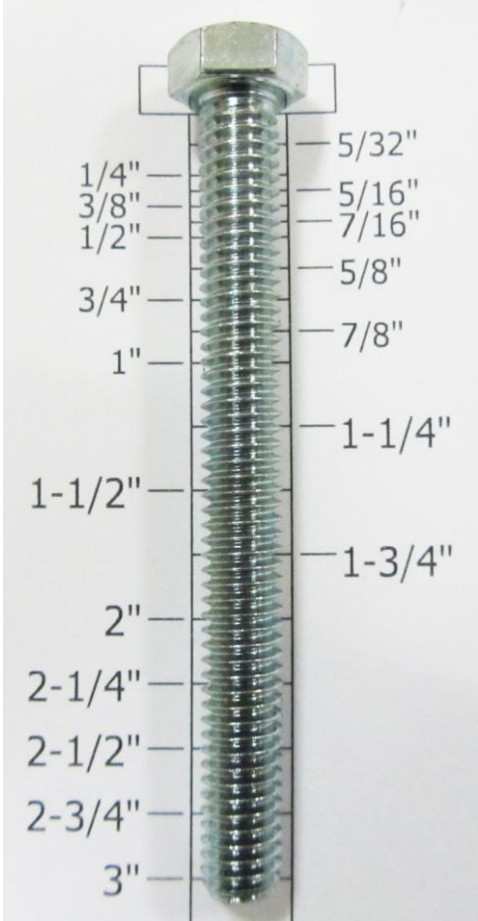

✚ Installations for WB-1066 (4 booths side by side).

- Take out **BM-2**.
- Fasten **BM-2** to **BS-2** with:

Part name	Description	Photos	Q'ty	Grainger Model #
Hex Screw	5/16" x 3"		2	1YU39
Flat Washer	5/16" x OD23 x 2T		2	*1JY31

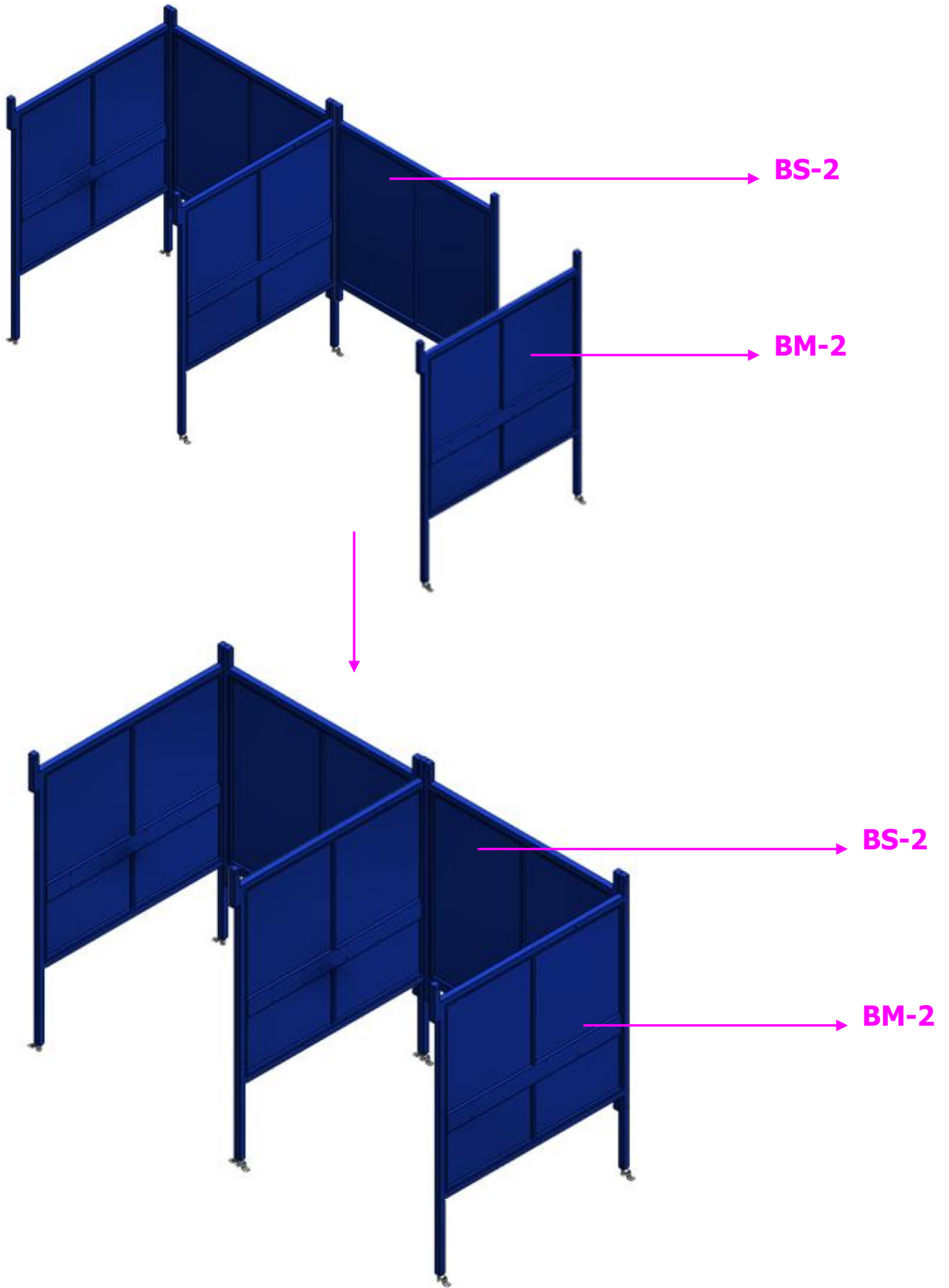

(* Hardware item at similar spec available locally.

✦ Installations for WB-1066 (4 booths side by side).

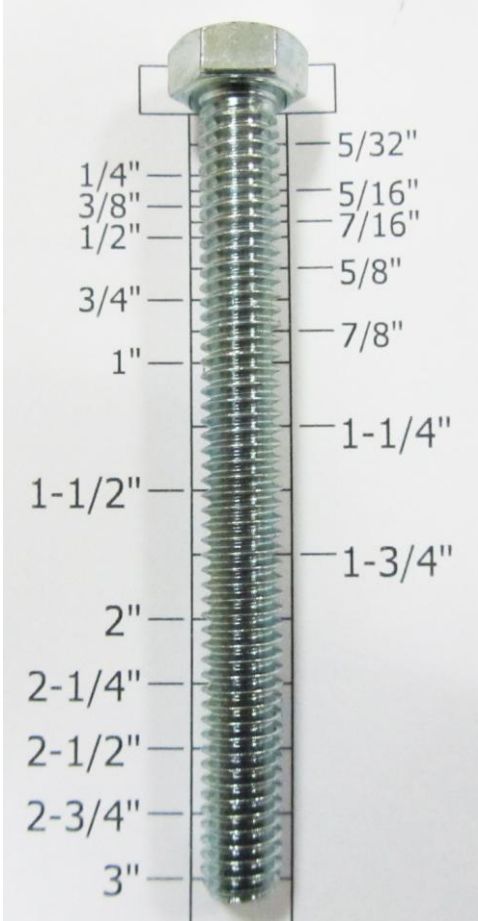

✚ Installations for WB-1066 (4 booths side by side).

- Take out **BS-3**.
- Fasten **BS-3** to **BM-2** with:

Part name	Description	Photos	Q'ty	Grainger Model #
Hex Screw	5/16" x 3"		2	1YU39
Flat Washer	5/16" x OD23 x 2T		2	*1JY31

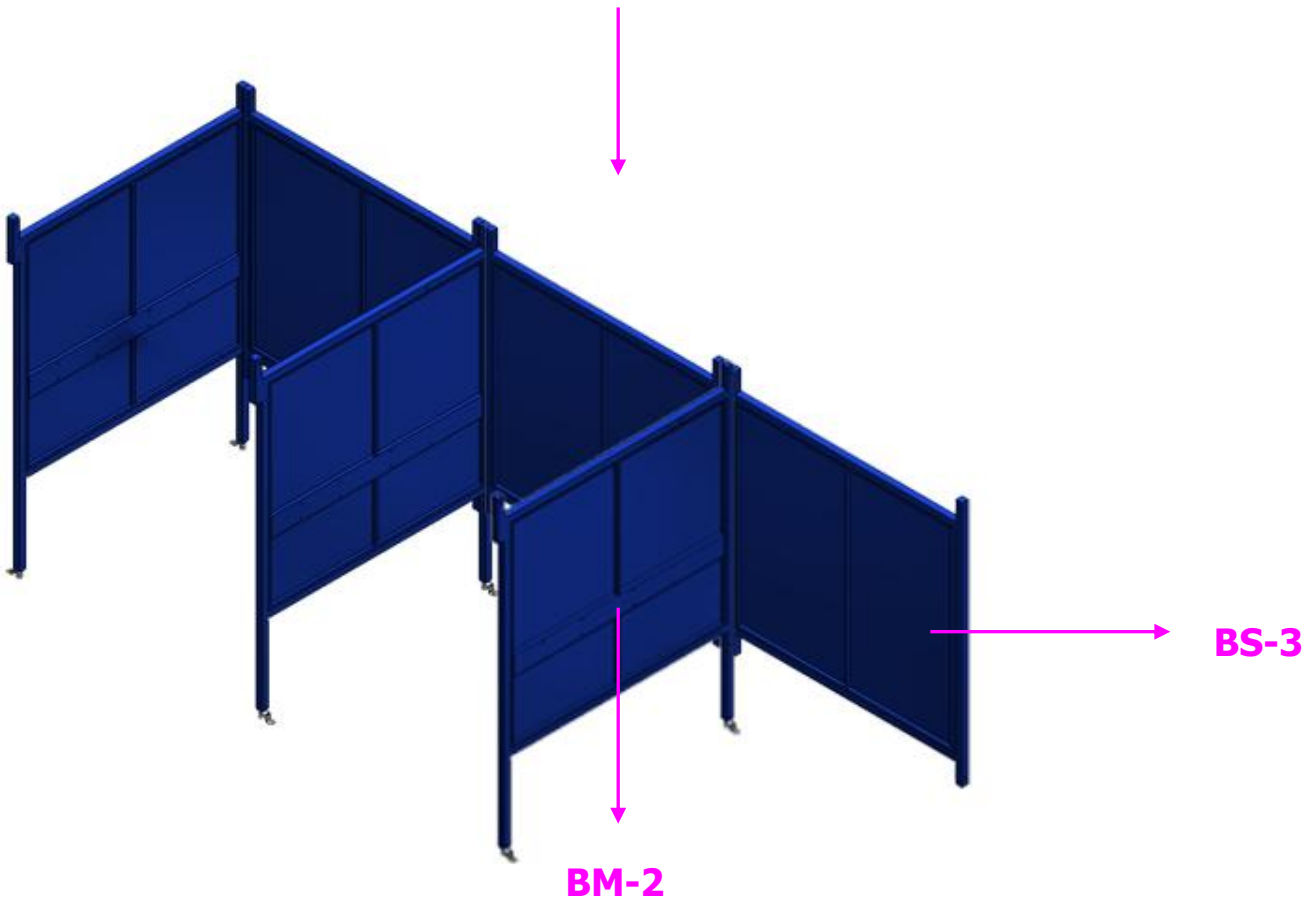
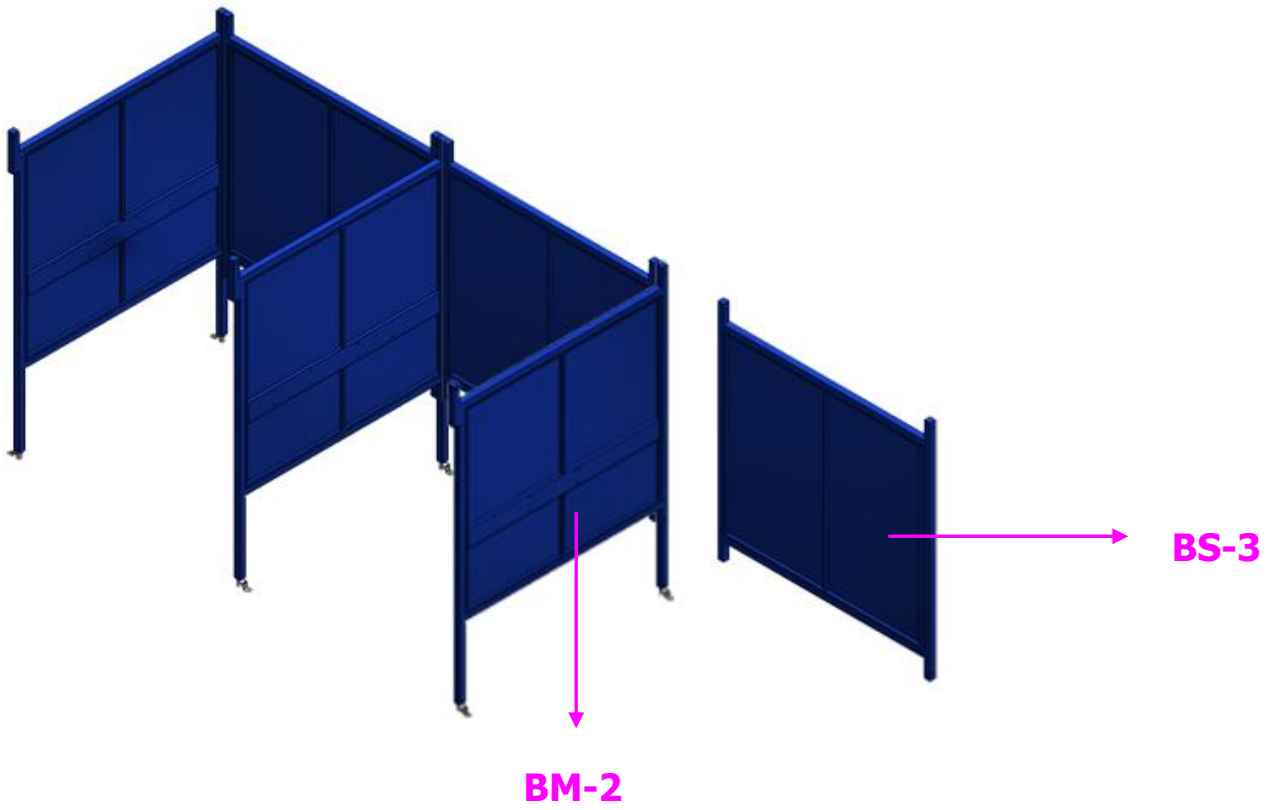

(* Hardware item at similar spec available locally.

✦ Installations for WB-1066 (4 booths side by side).

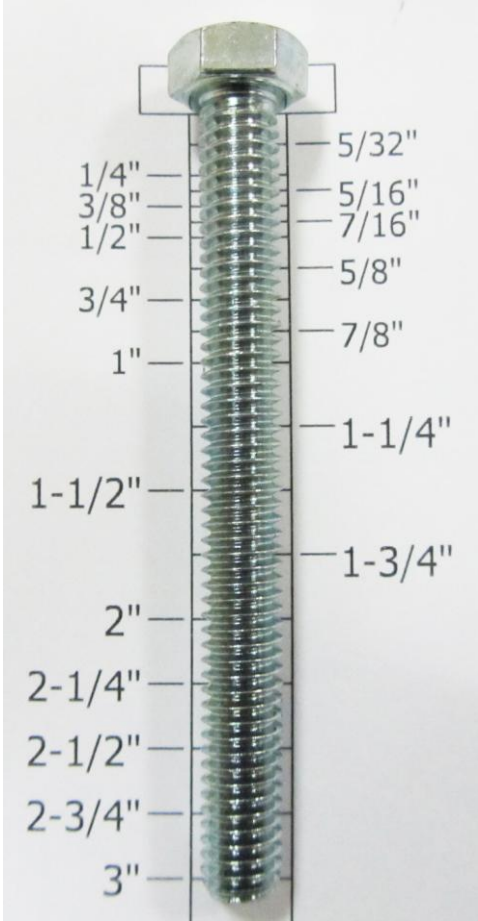

✦ Installations for WB-1066 (4 booths side by side).

- Take out **BM-3**.
- Fasten **BM-3** to **BS-3** with:

Part name	Description	Photos	Q'ty	Grainger Model #
Hex Screw	5/16" x 3"		2	1YU39
Flat Washer	5/16" x OD23 x 2T		2	*1JY31

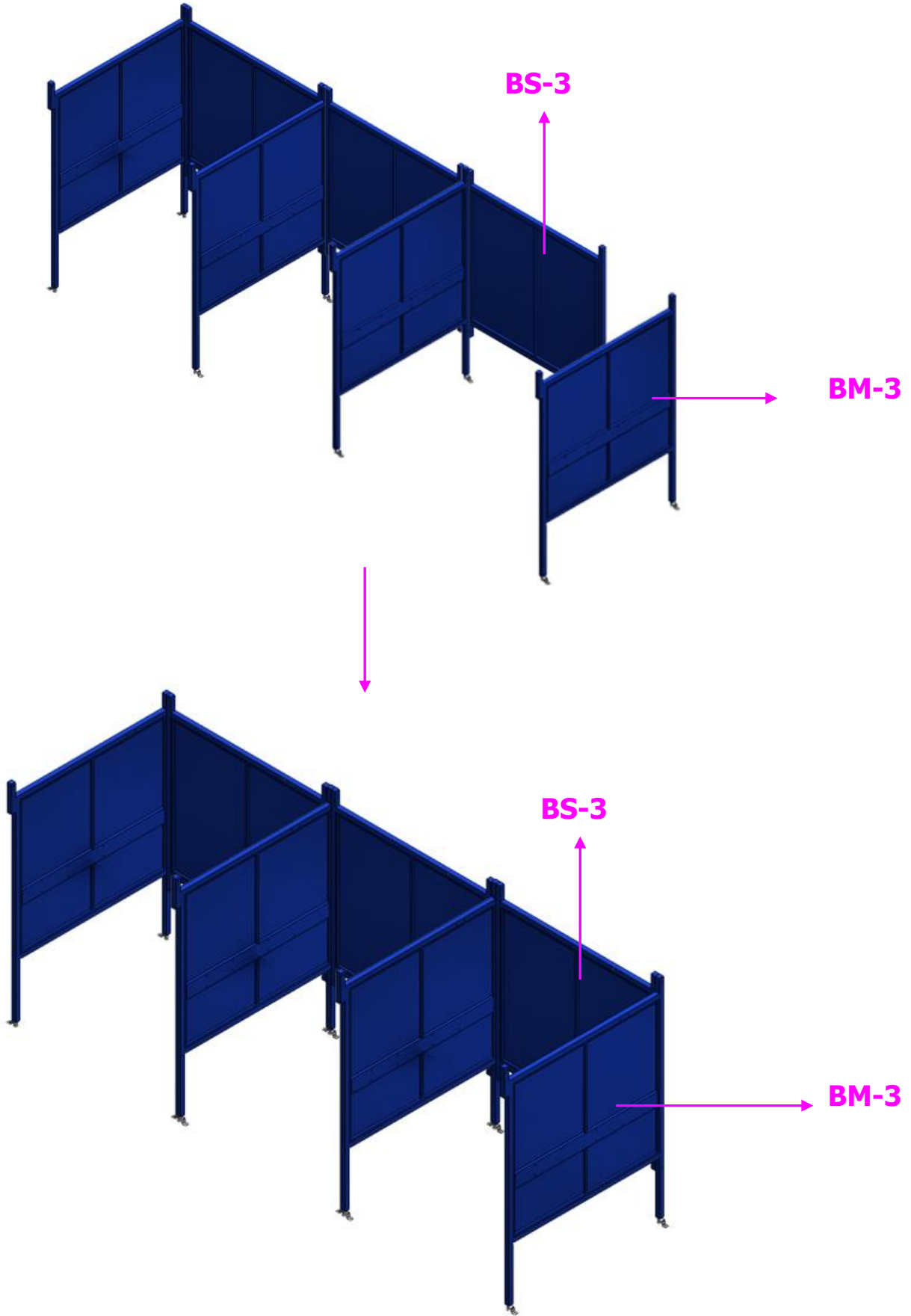

(* Hardware item at similar spec available locally.

✦ Installations for WB-1066 (4 booths side by side).

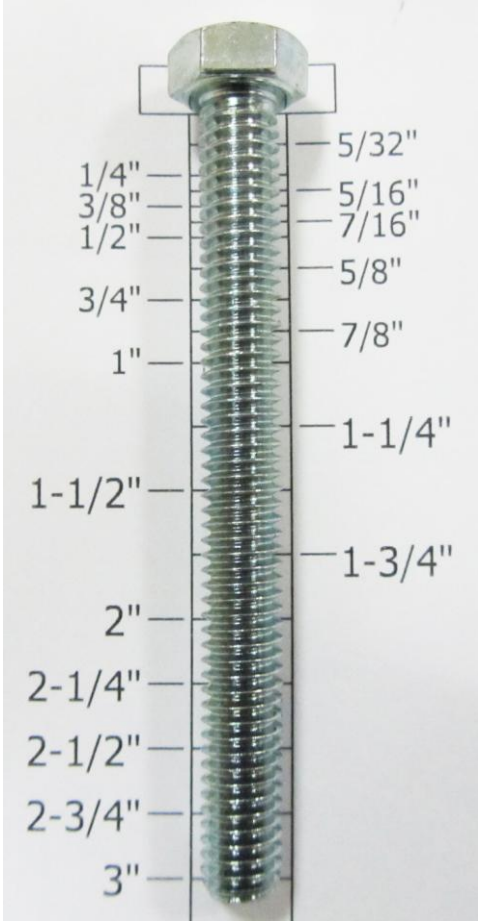

✚ Installations for WB-1066 (4 booths side by side).

- Take out **BS-4**.
- Fasten **BS-4** to **BM-3** with:

Part name	Description	Photos	Q'ty	Grainger Model #
Hex Screw	5/16" x 3"		2	1YU39
Flat Washer	5/16" x OD23 x 2T		2	*1JY31

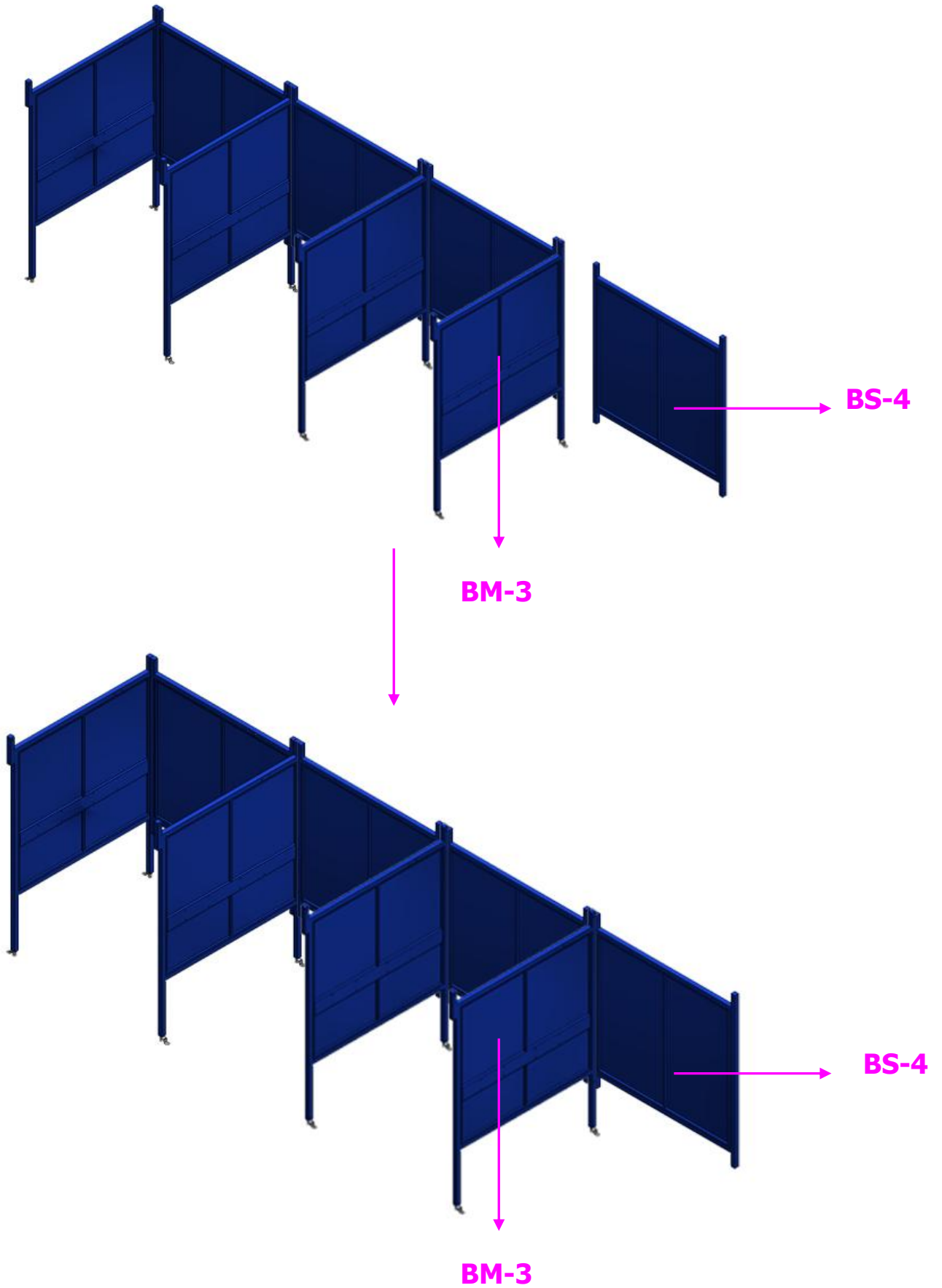

(* Hardware item at similar spec available locally.

✦ Installations for WB-1066 (4 booths side by side).

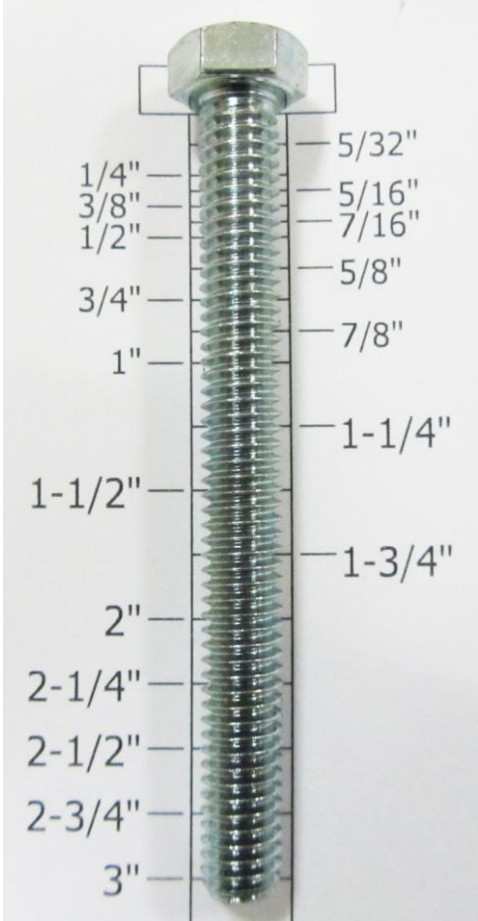

✚ Installations for WB-1066 (4 booths side by side).

- Take out **BR**.
- Fasten **BR** to **BS-4** with:

Part name	Description	Photos	Q'ty	Grainger Model #
Hex Screw	5/16" x 3"		2	1YU39
Flat Washer	5/16" x OD23 x 2T		2	*1JY31

(* Hardware item at similar spec available locally.

✦ Installations for WB-1066 (4 booths side by side).

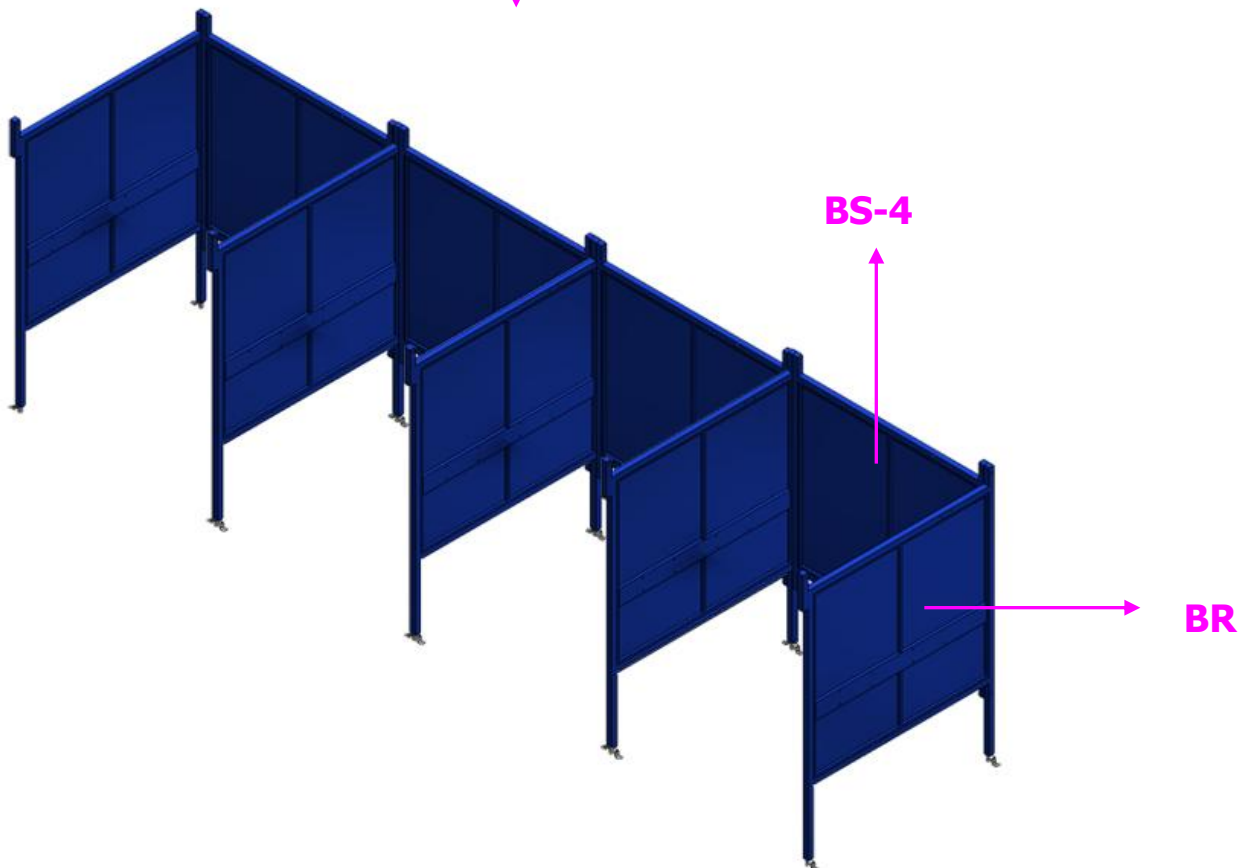
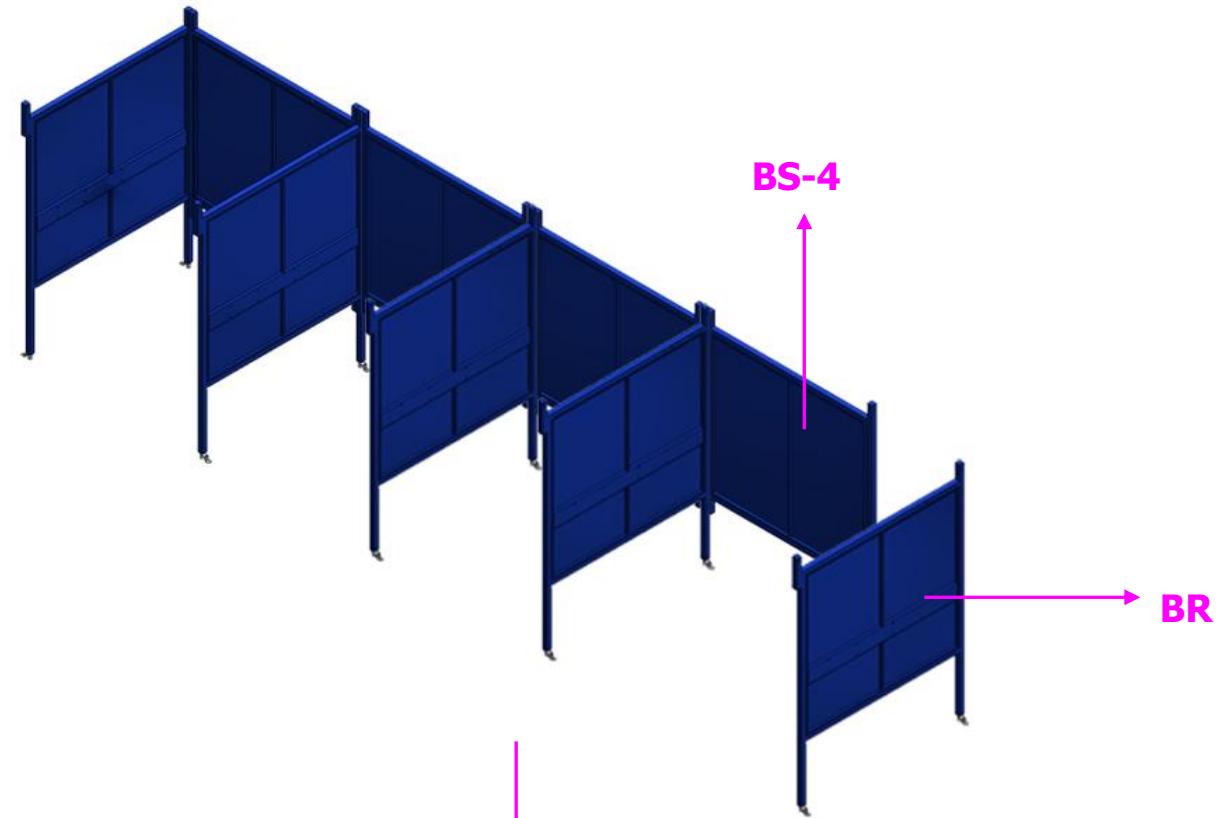

✚ Installations for WB-1066 (4 booths side by side).

- Take out **Working Light base**.
- Fasten **Working Light base** to **BS-1~4** with:

Part name	Description	Photos	Q'ty	Grainger Model #
Hex Screw	1/4" x 3/4"		16	1UY24
Flat Washer	1/4" x OD19 x 2T		16	*1JY29

(*) Hardware item at similar spec available locally.

Installations for WB-1066 (4 booths side by side).

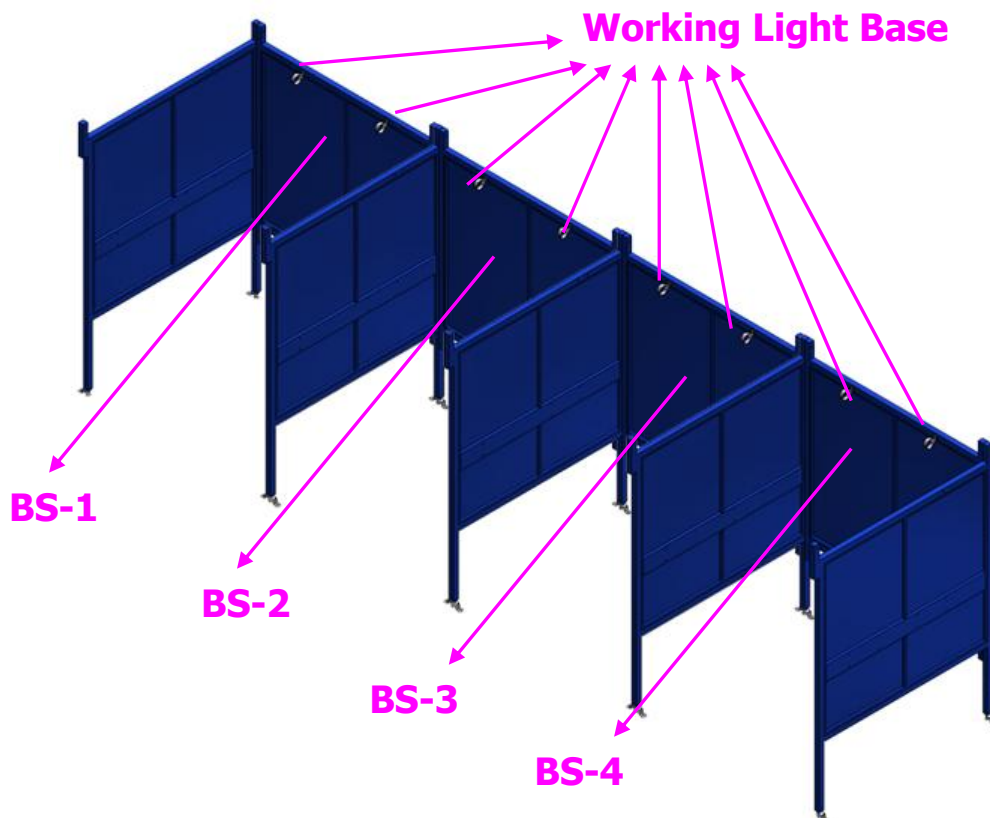
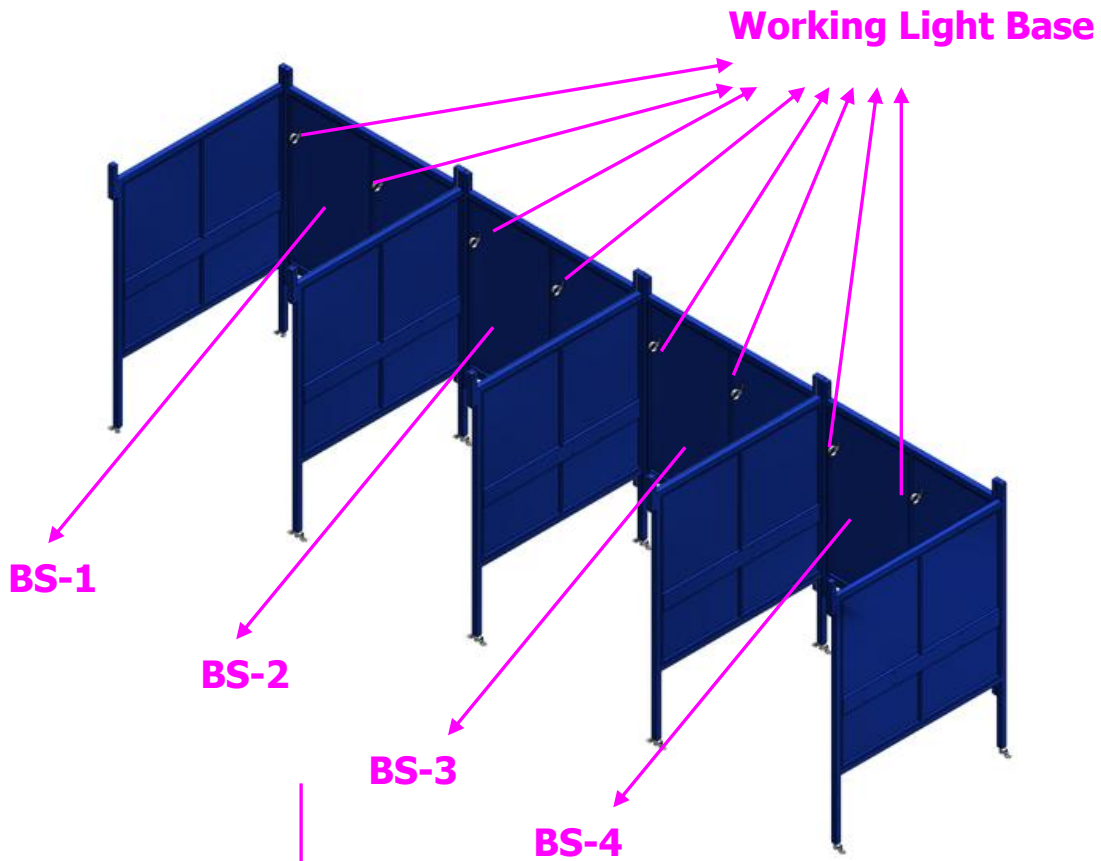

✦ Installations for WB-1066 (4 booths side by side).

- Take out **Working Light**.
- Assemble the **Working Light** to the base.

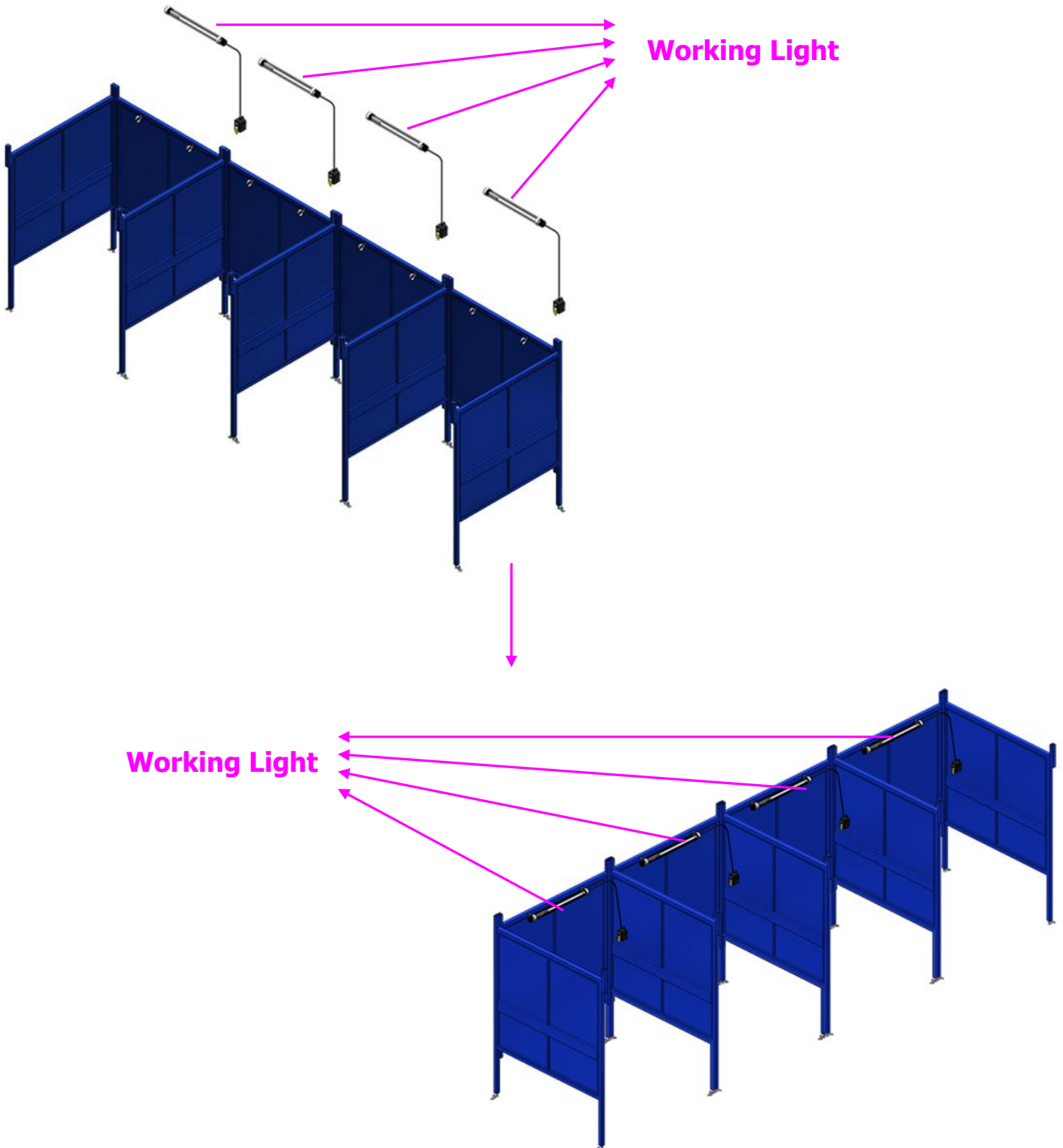

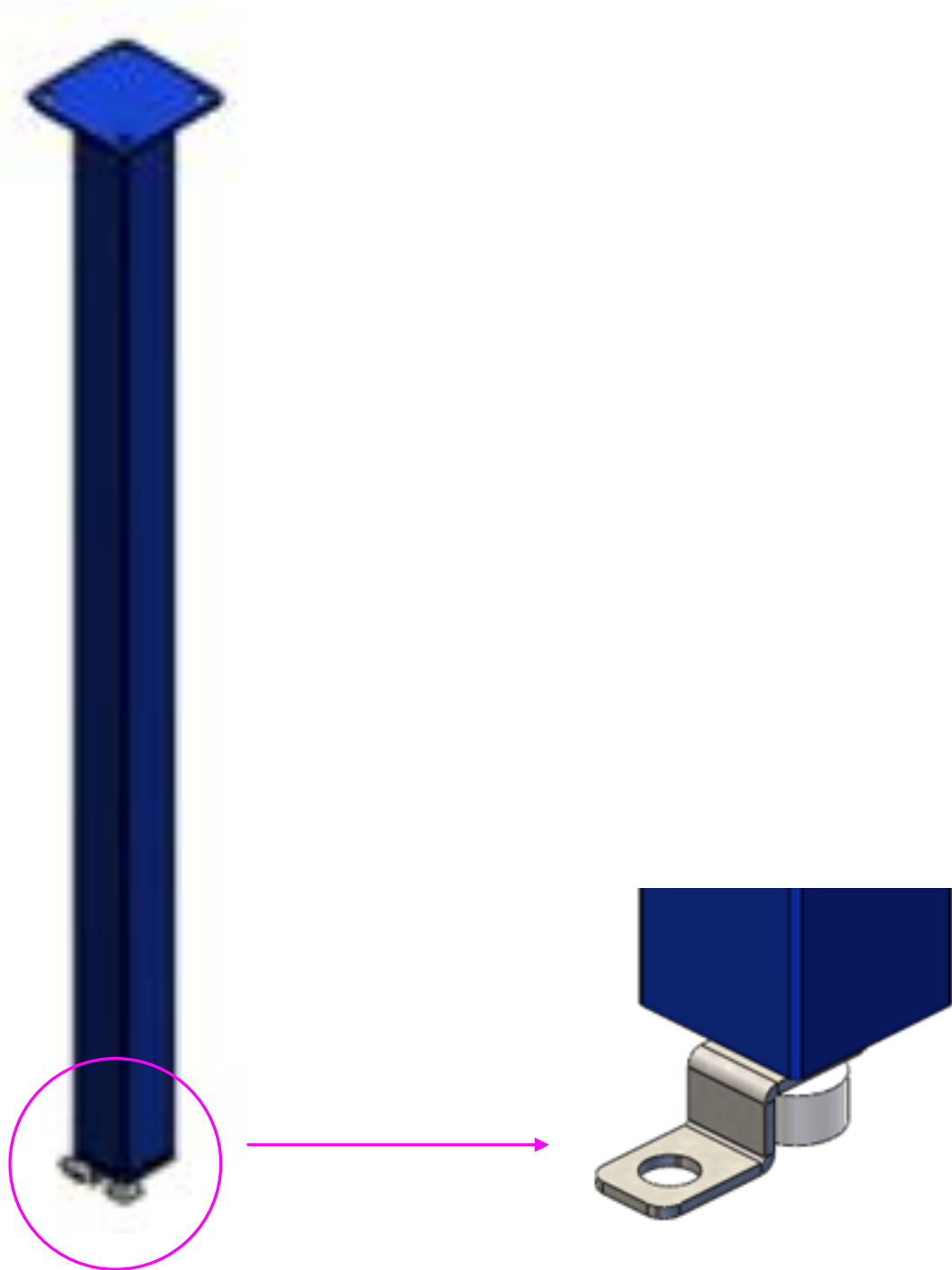

✦ Installations for WB-1066 (4 booths side by side).

- Take out **Adjustable Feet**.
- Fasten **Adjustable Feet** to **TG**.



✚ Installations for WB-1066 (4 booths side by side).

- Take out **TB**.
- Fasten **TG** to **TB** with:

Part name	Description	Photos	Q'ty	Grainger Model #
Flat Washer	5/16" x OD18 x 2T		2	*1JY31
Hex Nut	5/16"		2	2FE51

(*) Hardware item at similar spec available locally.

Installations for WB-1066 (4 booths side by side).

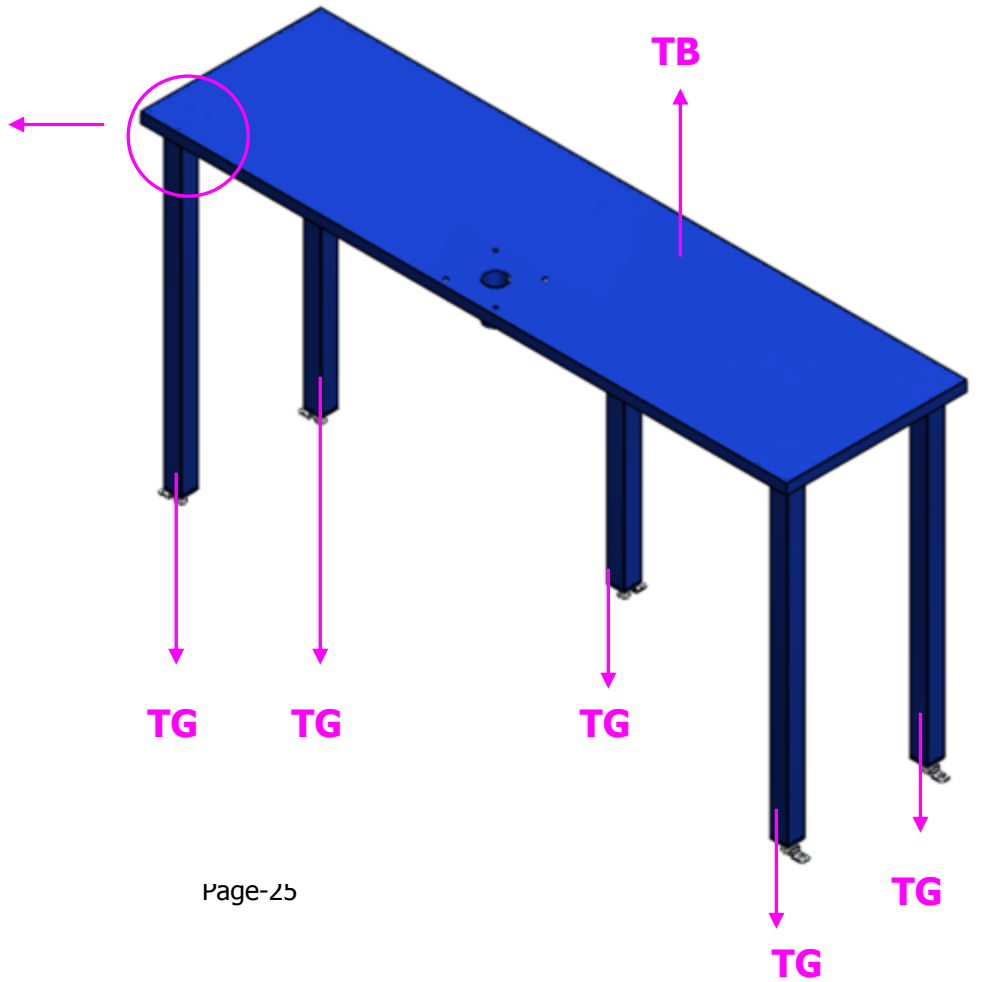
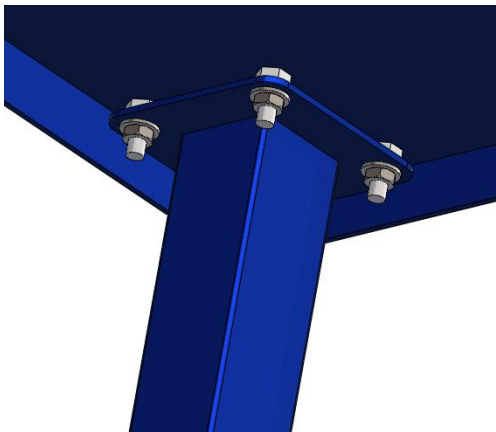
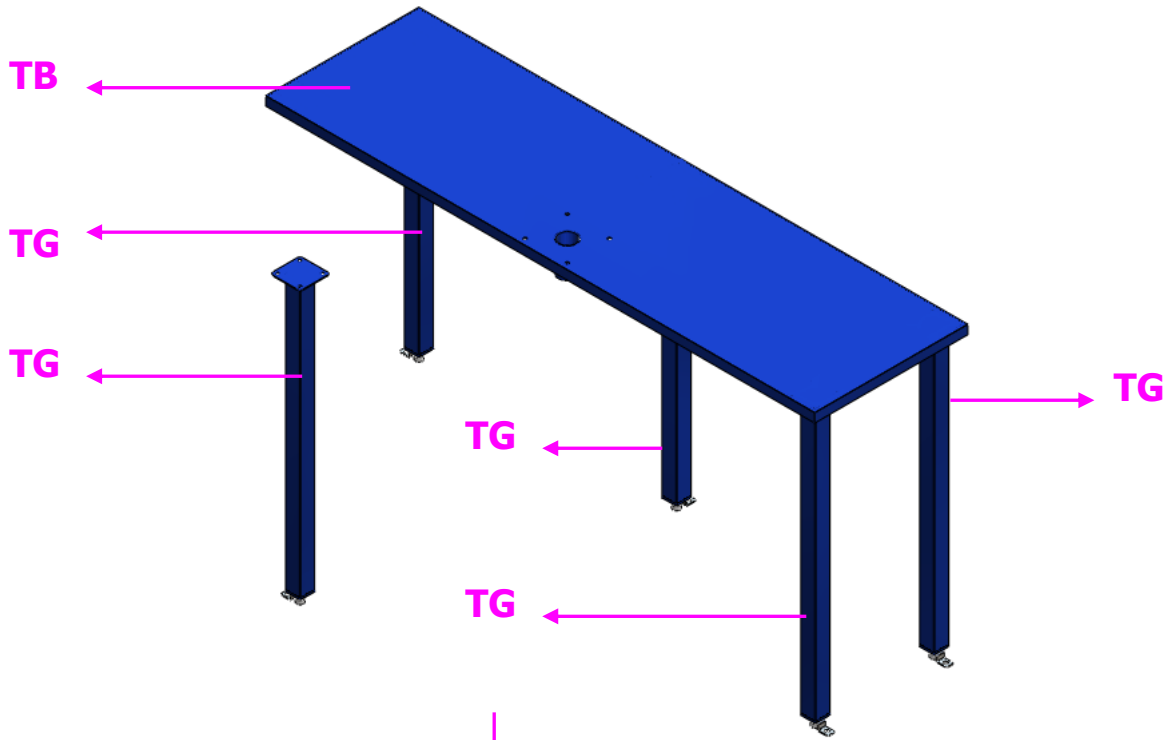

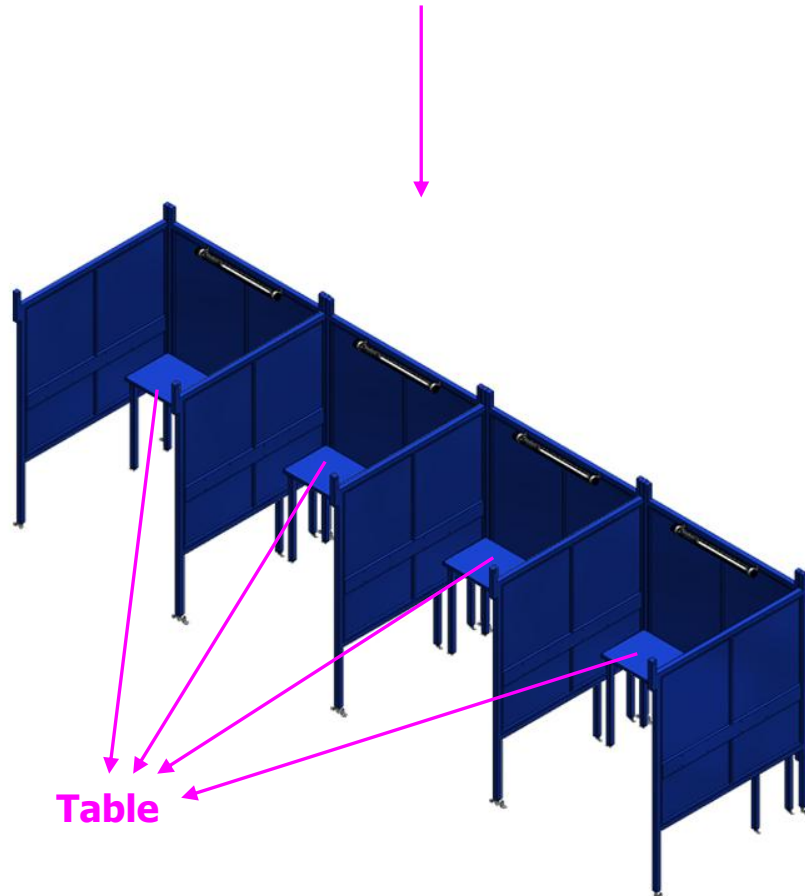
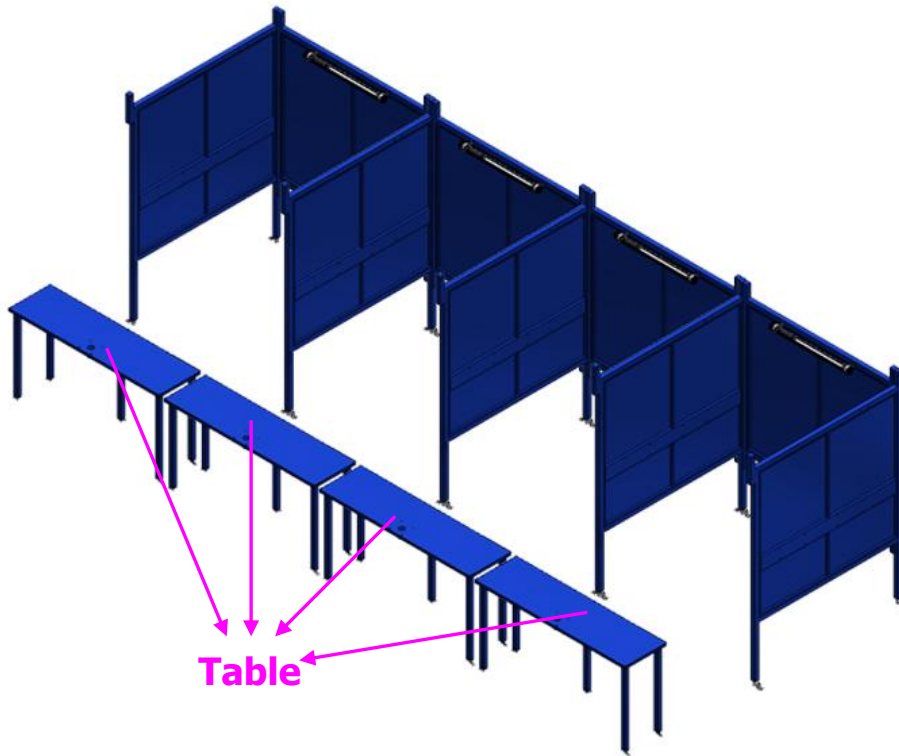

✚ Installations for WB-1066 (4 booths side by side).

- Assemble **Table** into the booth.



✚ Installations for WB-1066 (4 booths side by side).

- Take out **A**.
- Fasten **A** to **BL**, **BM-1~BM-3** and **BR** with:

Part name	Description	Photos	Q'ty	Grainger Model #
Hex Screw	5/16" x 3/4"		8	1YU33
Flat Washer	5/16" x OD23 x 2T		8	*1JY31

(*) Hardware item at similar spec available locally.

Installations for WB-1066 (4 booths side by side).

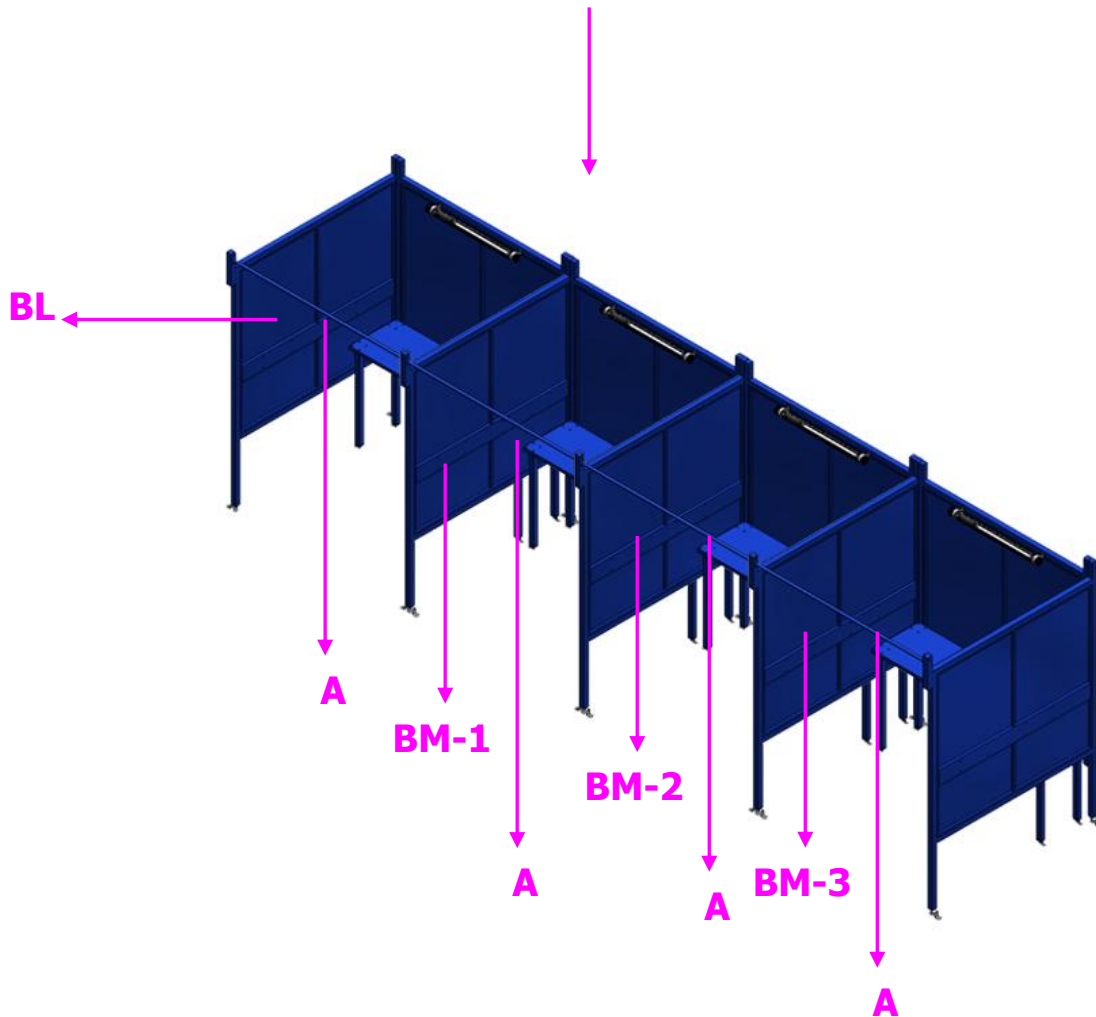
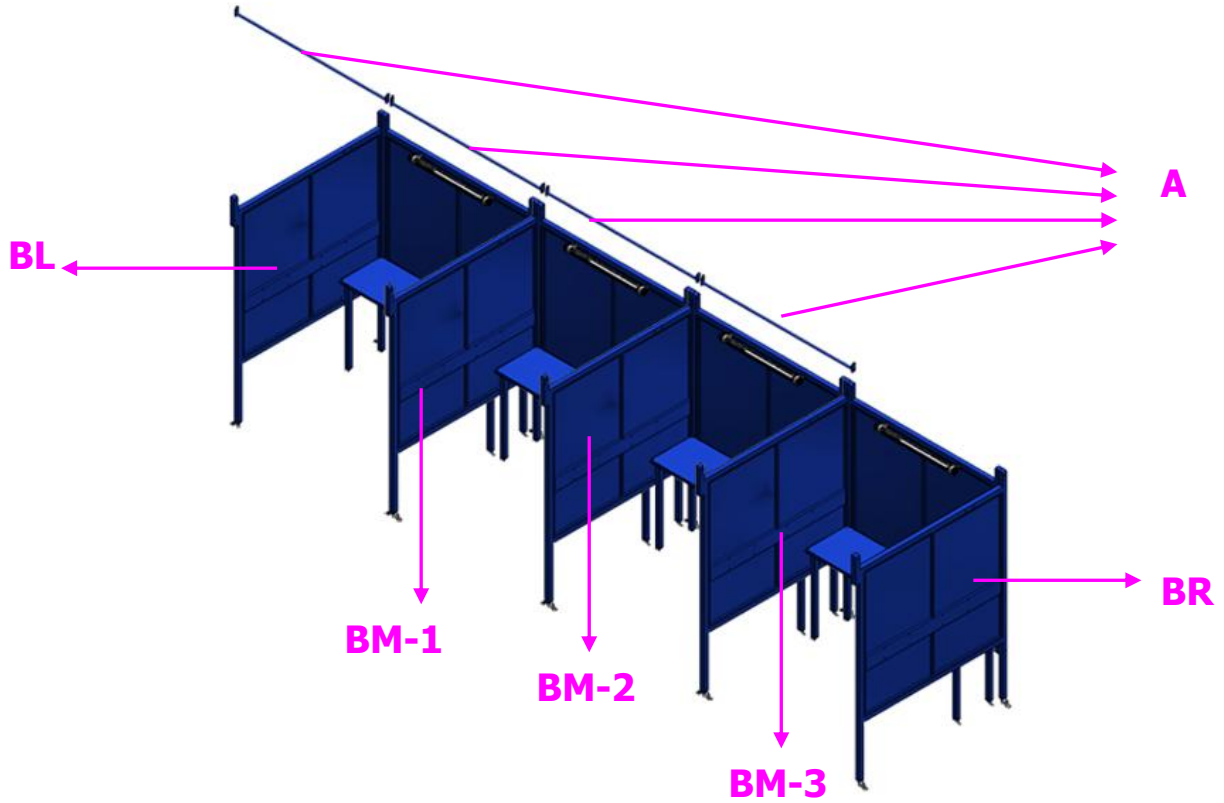

✚ Installations for WB-1068 (3 booths side by side).

- Fasten **Sleeve Anchor** for legs to field bolted if needed.

Assembly completed.

Part name	Description	Photos	Q'ty	Grainger Model #
Sleeve Anchor	3/8" x 3"		36	3A475

✦ Installations for WB-1068 (3 booths side by side).

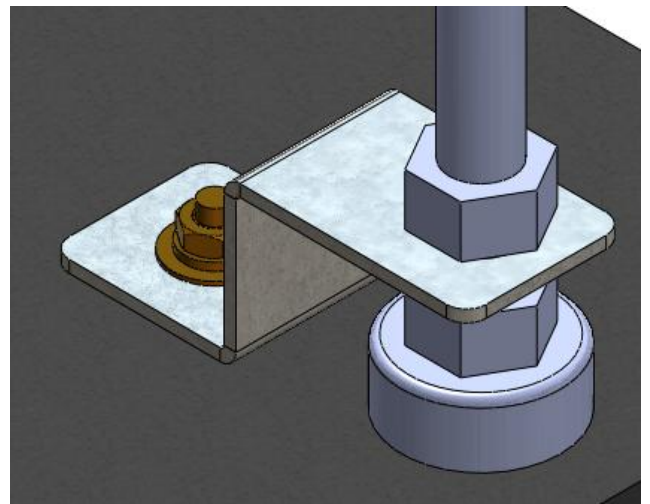
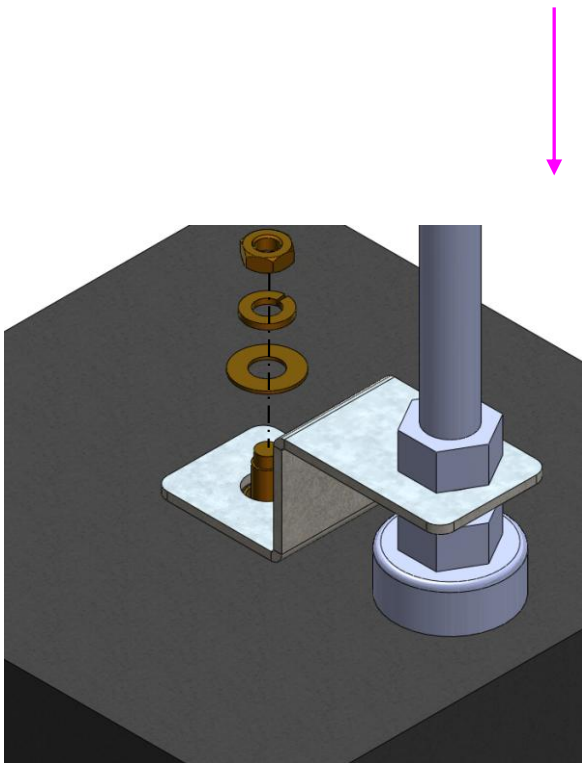
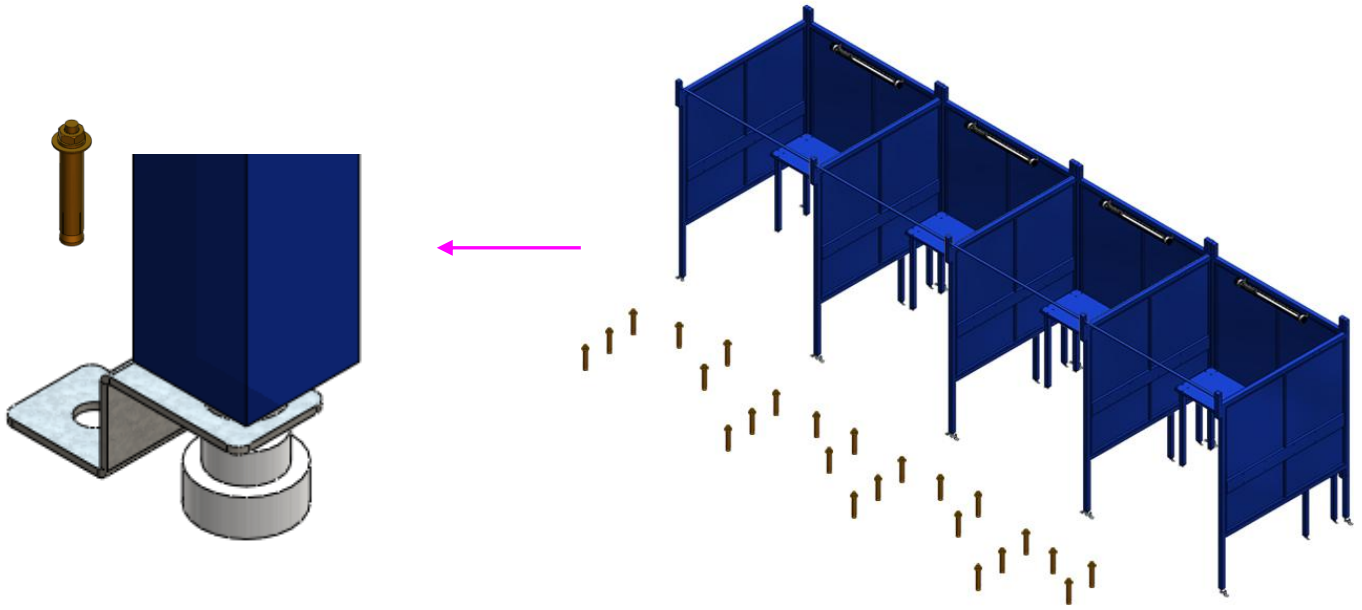

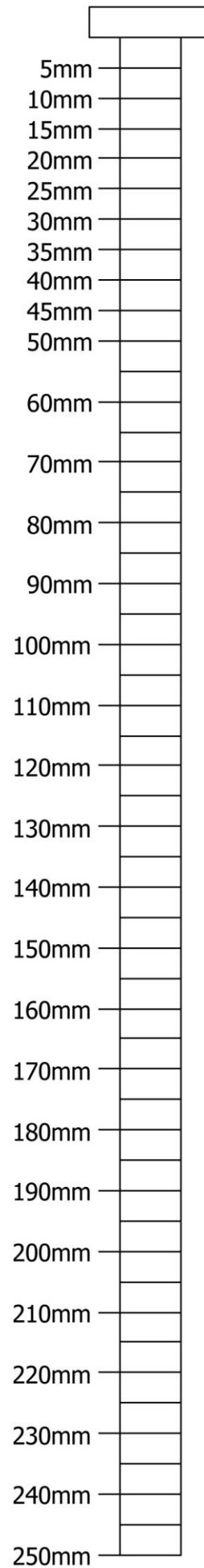
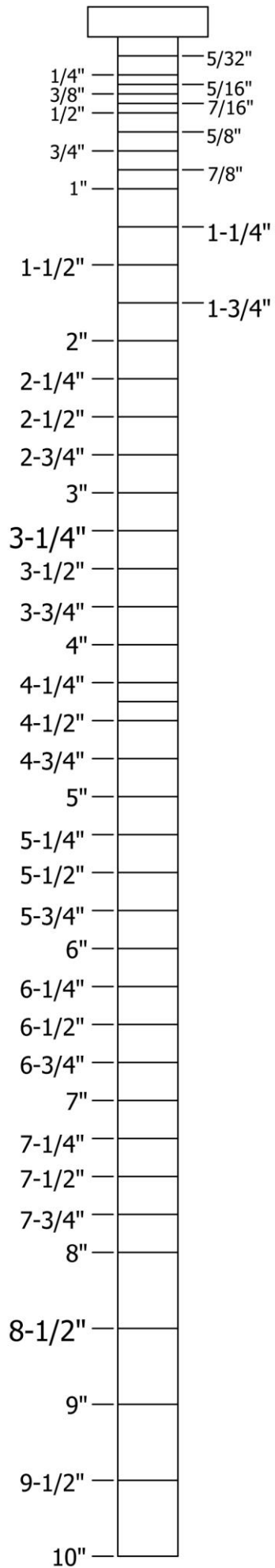

Flat Washer: 1/4"

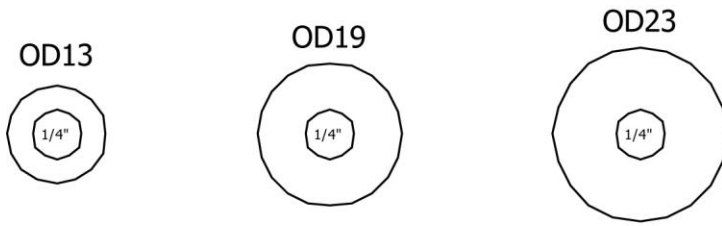

Flat Washer: 5/16"

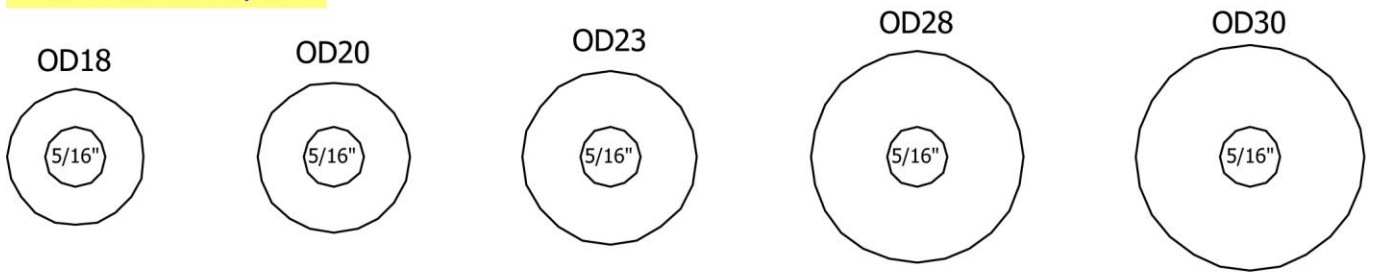

Flat Washer: 3/8"

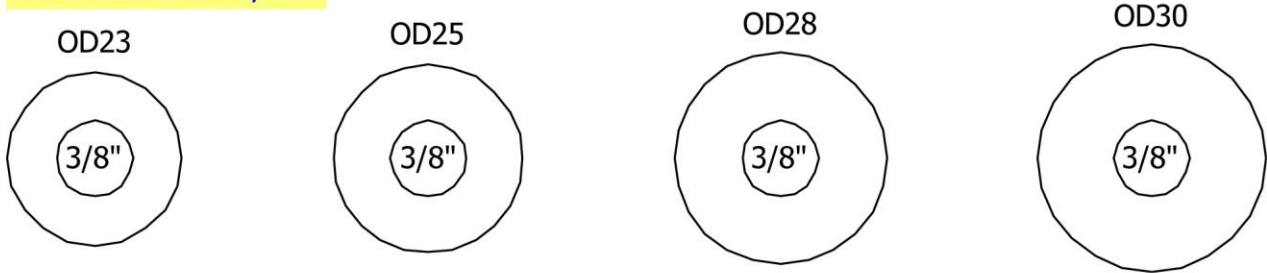

Flat Washer: 1/2"

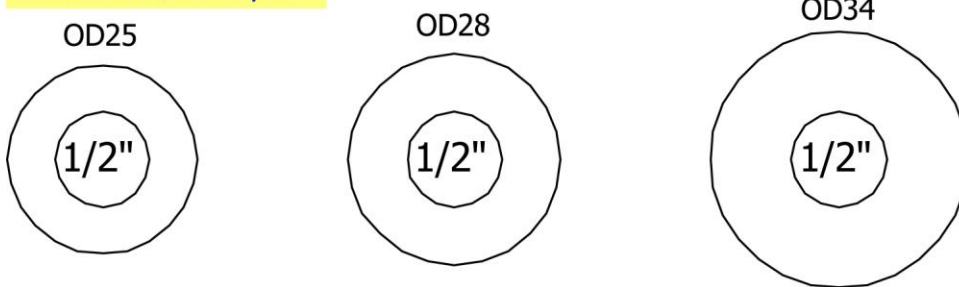

Flat Washer: 7/16"

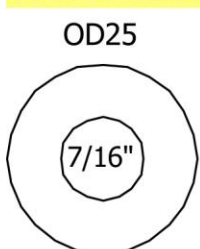

Flat Washer: 5/8"

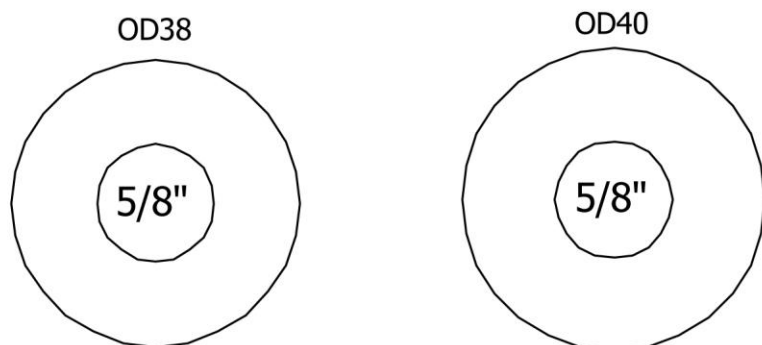

HEX NUT

3/16"



HEX NUT

1/4"



HEX NUT

5/16"



HEX NUT

3/8"



HEX NUT

1/2"

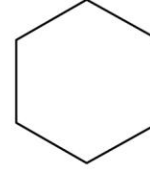

HEX NUT

5/8"

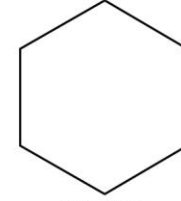

HEX NUT

NYLON HEX NUT

1/4"



NYLON HEX NUT

5/16"

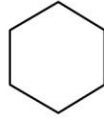

NYLON HEX NUT

3/8"



NYLON HEX NUT

1/2"



NYLON HEX NUT

5/8"

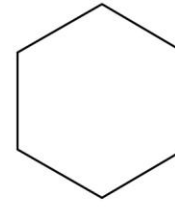

NYLON HEX NUT

ACORN NUT

1/4"



ACORN NUT

5/16"



ACORN NUT

3/8"



ACORN NUT

1/2"

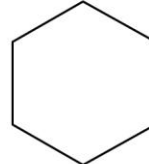

ACORN NUT

5/8"

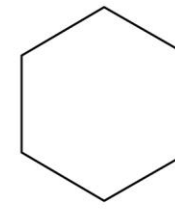

ACORN NUT

WING NUT

1/4"



WING NUT

5/16"



WING NUT

3/8"



WING NUT

Rubber Washer

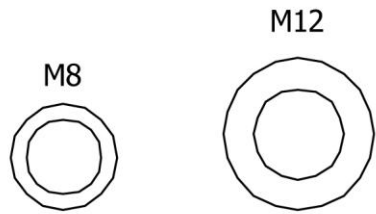

Split Lock Washer

