

WET DUST COLLECTION SYSTEM - MODELS DC 1200/1800/2200/2800/3700/4700/5500



OPERATING MANUAL

Customer: _____
Model #: _____
Serial #: _____
Voltage: _____

CUSTOMER SERVICE USA
Technical Service & Parts

Parts & Service: 800 • 697-1444
FAX: 612 • 721-1736
EMAIL: parts@midwestgroupone.com
service@midwestgroupone.com

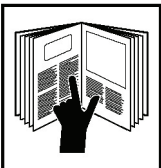

For additional information, refer to the Engineering Manual specific to this machine.

©2001 HCS, LLC 800-748-0241



Table of Contents

Wet Dust Collection Systems

SECTION 1	<i>Safety Directions</i>	
	Introduction	1-3
	General Safety Precautions	1-5
	- Including Lockout/Tagout Procedure	
	- Safety Warnings	
	Safety Instructions during Operation	1-9
	Safety Instructions for Maintenance of Machine	1-12
	Safety Instructions during Installation of Machine	1-13
	Additional Safety Information for Sanders	1-14
	Additional Safety Information for Wet Dust Collectors	1-15
	Safety Label Documentation	1-17
	Safety Label Kit: Bill of Material, Illustrations	1-18 TO 1-21
SECTION 2	<i>Introduction</i>	
	Introduction	2-1
	Wet Dust Collector Bulletin	2-2
	Technical Data & Specifications	2-3
	Engineering Floor Plan	2-4
	Limited Warranty Policy	2-5
	Service Record Form	2-7
	Notes	2-8
SECTION 3	<i>Pre-Installation</i>	
	Pre-Installation Instructions	3-1
	Pre-Installation Checklist	3-3
SECTION 4	<i>Installation</i>	
	Step by Step Instruction	4-1 TO 4-5
SECTION 5	<i>Operation</i>	
	Step by Step Instruction	5-1 TO 5-2

SECTION 6	<i>Scheduled Maintenance</i>	
	Sludge Removal	6-1
	Spare Parts	6-1
	Discharge Outlet Pipes	6-2
	General Application Information	6-2
	Sludge Disposal	6-2
	- Examples	6-3

SECTION 7	<i>Replacement Parts Installation</i>	
	Safety Notice/Customer Service Contact Information	7-1

SECTION 8	<i>Troubleshooting</i>	
	Problem/Cause/Correction Chart	8-1 TO 8-2

SECTION 9	<i>Recommended Spare Parts List</i>	9-1
------------------	--	-----

SECTION 10	<i>Illustrated Parts List</i>	10-1
-------------------	--------------------------------------	------

SECTION 11	<i>Schematics & Programs</i>	11-1
-------------------	---	------

SECTION 12	<i>Vendor Information</i>	12-1
	Not Applicable to this model	

How To Reach Us

Section 1
Safety Directions



Safety Directions for Midwest Sandright / Rand-Bright Machines

Table of Contents

	SECTION	PAGE #
1.	Introduction	1-3
2.	General Safety Precautions Including Lockout/Tagout Procedure Warnings Safety Warnings	1-5
3.	Safety Instructions during Operation	1-9
4.	Safety Instructions for Maintenance of Machine	1-12
5.	Safety Instructions during Installation of Machine	1-13
6.	Additional Safety Information for Sanders	1-14
7.	Additional Safety Information for Wet Dust Collectors	1-15
8.	Safety Label Documentation	1-17
9.	Safety Label Kit: Bill of Material & Illustrations	1-18

1. INTRODUCTION



This is a Safety Alert symbol. It alerts the user to potential personal injury hazards. Obey all safety messages that follow this symbol to avoid possible injury or death.

IMPORTANT NOTE:

Persons unable to read English must have this manual translated and explained to them before operating or maintaining the machine. Everyone working on the machine must know how to operate it safely and correctly to avoid possible injury.

AVISO:

Las personas que no pueden leer el ingles deben mander hacer la lectura de este manual antes de operar o mantener la maquina. Todos que hacen funcionar las maquina deben saber operaria con toda seguridad y con exactitud para evitar un dano.

⚠ WARNING

Serious injury or death may result if this machine is misused in any way. Midwest provides the following information and instructions for the intended use and care of this equipment, and relies upon the purchaser to see that these instructions are made clear to any and all persons installing, servicing, or operating the machine.

DO NOT INSTALL, OPERATE OR SERVICE THIS MACHINE UNTIL:

1. YOU have read and fully understand the safety instructions in this manual.
2. YOU have read and understand the operating procedures in this manual, especially knowing the location and function of all machine controls.
3. YOU have read and understand all safety and operating instruction placards and/or decals attached to the machine and its related accessories.
4. YOU have read and understood the installation and maintenance procedures contained in this manual.



Any service on this machine must be performed only by authorized, competent and trained personnel.

5. YOU have personally been trained by an authorized factory representative or qualified supervisor as to the proper and safe use of this machine and its related accessories.



This Operating Manual and Safety Instructions must be kept in the vicinity of the machine at all times so that it is accessible to the operator and maintenance personnel.





The following Safety Instructions are general recommendations for most common operations. Additional safety measures must be incorporated for your particular application.

Midwest Sandright, therefore, makes no warranty or representation as to the absolute correctness or sufficiency of these instructions.

Midwest assumes no responsibility for machine and/or software modifications or for use of parts other than those manufactured and/or approved in writing by Midwest. The use of non-approved parts, unauthorized service personnel, or machine modifications may result in poor performance or in an accident causing serious injury or death and will void the warranty.

REMEMBER...It is the responsibility of the user to be sure that the machine is in safe operating condition at all times, the operator follows the safe operating conditions at all times, and that the operator follows the safe operating procedures described in this manual and attached to the machine!

If you have any questions concerning the safe operation of this machine, contact your supervisor OR Midwest Sandright Customer Service Department:

- ①  Tel: 1-800-697-1444 OR 1-612-721-5347
- ②  Email: service@midwestgroupone.com
- ③  Fax: 1-612-721-1736

2. GENERAL SAFETY PRECAUTIONS

KNOW YOUR MACHINE

Read the Technical Manual carefully. Learn the machine applications and limitations as well as the specific potential hazards particular to the machine. The Technical Manual furnished with this machine includes instructions for installation, operation and service, plus additional safety information. You must follow these instructions carefully. Do not install, operate or service this machine until you have read and understood all safety and operating instructions. Do not take anything for granted.

BE ALERT

The best defense against injuries on any machine is to be alert. NEVER initiate a machine function unless you completely understand what the function will cause the machine to do. In addition to obeying these recommendations, it is important that the operator pay close attention to the work he is doing. No amount of adherence to safety rules or precautions will protect a careless operator from injury to himself or damage to the machine.

MAKE USE OF SAFETY EQUIPMENT

Do not operate this machine unless all guards, shields, covers, interlocks and other safety devices are in place and functioning properly. Report missing guards, parts or other abnormalities to your supervisor immediately. NEVER defeat safety switches!

AVOID DANGEROUS ENVIRONMENT

NEVER use this machine in damp or wet locations. Floors must not be slippery due to water, dust, chips, oil, etc. Keep machine and surrounding area clean and well lighted. Do not leave loose objects on or around machine. Always provide adequate workspace. Poor housekeeping can be dangerous!

NEVER STAND ON MACHINERY

NEVER climb or stand on the machine or in any working area at any time when the machine is running. Do not store materials above or near the machine so that it is necessary to climb on the machine or stand in the path of the material to reach them.

USE LOCKOUT/TAGOUT PROCEDURE WHEN SERVICING OR MAKING ADJUSTMENTS ON MACHINE



Under OSHA 1910.147, every plant must have and enforce a Lockout/Tagout Procedure. Your procedure should include these key features:

1. Announce lockout to other personnel.
2. Turn power OFF at main panel.
3. Each person working on the machine should lockout power in OFF position with their own lock.
4. Each person must put key in his/her own pocket.
5. Clear machine of all personnel.
6. Test lockout by hitting START button.
7. Block, chain or release stored energy sources. [work on machine]
8. Before restarting machine, make sure no one is near the machine.
9. Take key from pocket.
10. Unlock the lockout device.
11. Turn power on at main panel.
12. Announce machine is ON to other personnel.

WATCH YOUR HANDS AND LIMBS

The functions of this machine make it impossible to eliminate all pinch areas and cut points.

Therefore:

1. Stay away from the path of the material when the machine is running.
2. NEVER remove chips, dust or scrap when the machine is running.
3. NEVER overreach.
4. Keep proper footing and balance at all times.
5. NEVER jeopardize your hands! Keep your hands away from all belts and rollers. Never reach where you cannot see. DO NOT place hands or finger between work piece and conveyors or rollers.
6. NEVER make machine or tooling adjustments of any kind when the machine is running. Always disconnect main power supply before adjusting the machine in any way or changing belts or platen graphite!



Refer to “LOCKOUT/TAGOUT PROCEDURE”, General Safety Precautions, page 1-6 above.

▲WARNING

Abrasive belts continue to turn after power is turned off and/or disconnected. Always be sure that belts have stopped turning before adjusting, changing or servicing!

WEAR PROPER APPAREL

1. Wear safety goggles/glasses with eye shields at all times.
2. Always wear safety shoes with steel toes and slip resistant soles.
3. Hearing protection should be worn when equipment is operated with noise levels in excess of that which is safe for unprotected ears.
4. If the operator has long hair, it should be tucked under a cap or tied back and up.
5. NEVER wear gloves. Gloves are easily caught in moving parts. Take them off before “turning on” or operating the machine.
6. NEVER wear loose-fitting clothing. Remove all jewelry, rings, watches, necklaces, neckties, etc., before operating or servicing the machine.



FIRE & EXPLOSION PROTECTION

This machine will create dust and under certain conditions, sparks. As such, there may be a fire and explosion hazard. Fire and explosion detection and suppression systems vary depending on what materials that you are processing and using, and they are something that you must coordinate throughout your factory. Thus, you are solely responsible for determining what fire and explosion protection is necessary for your particular facility, including this machine, and you must supply any necessary fire and explosion detection and suppression equipment or systems.



Loose electrical connections and dust do not mix.

Periodically check to see that all electrical connections are tight per the scheduled maintenance in Section 6 of this manual.

KEEP VISITORS AWAY

Persons other than the machine operator, including all plant personnel and visitors, should stay out of the machine area during operation. Visitors should always be kept at a safe distance from the machine and provided with the appropriate safety protection.

SAFETY WARNINGS



DO NOT operate machine with any guards removed.



DO NOT open doors while machine is running.



NEVER clean or lubricate machine while running.



NEVER attempt maintenance or adjustments with the power “ON” unless specified in the instructions.



Abrasive belts are perishable media. They should be discarded and replaced with new belts when worn.



Care and caution should be used when placing parts on the conveyor. **DO NOT** grasp the material in such a way that pinch points can capture body parts or clothing. **DO NOT** wear gloves.



The position indicator does not specify material thickness. It provides a relative position of the conveyor bed so that similar results can be achieved on subsequent runs.



Modifications to the original design or construction are not authorized unless written approval is obtained from the factory.

3. SAFETY INSTRUCTIONS & PRECAUTIONS DURING OPERATION

BEFORE OPERATING THE MACHINE

1. Be sure you read and fully understand the operating instructions and safety information found in this manual.
2. Control panels, transformers, motors, junction boxes and other parts have high-voltage terminals. Removal of covers presents a risk of a severe electric shock resulting in serious injury or death.
3. Know the locations and functions of all controls and switches before operating them. Avoid touching switches accidentally.
4. NEVER touch a switch with wet hands that may result in electric shock.
5. Know where the Emergency Stop push button and/or cables are located so you can operate it at any time without having to look for it.
6. Check the condition of all cables, cords and exposed electrical wires to be sure that their insulation is not damaged.
7. Switches and levels should be checked for smooth operation.
8. Oil levels and lubricating points should be checked and serviced as recommended in this manual.
9. Close control panel and electrical enclosure doors and covers.
10. If a job is to be done by two or more persons, coordinating signals should be given and acknowledged at each step of the operation.
11. Be sure that proper safety equipment is worn at all times.

BEFORE CONTROL POWER SWITCH HAS BEEN TURNED ON

1. Insure that all adjustments are complete, guards and other safety equipment are in place and personnel are clear from the area. NEVER make adjustments unless you are certain the main power supply is off and the sanding belt has stopped turning.



**Refer to “LOCKOUT/TAGOUT PROCEDURE”,
General Safety Precautions, page 1-6 above.**

2. After making adjustments or changing belts, always secure abrasive head, etc. Make certain all bolts are tightened properly.
3. Belts should always conform to the machine specification, dimensions and types. Keep belts clean for best and safest performance. Insure that all sanding belts are mounted correctly for the direction of rotation. NEVER use ripped or damaged belts!
4. Remove adjusting keys, wrenches and other loose objects from the machine before turning it on.
5. NEVER operate the machine after taking medication that may impair your senses or while under influence of drugs or alcohol. Persons with illnesses that cause dizziness or fainting should NEVER operate equipment.
6. Report any loose, worn or broken parts to your supervisor.
7. Check drive belt tensions and adjust or replace as required.
8. Check the machine for proper alignment.

AFTER CONTROL POWER SWITCH HAS BEEN TURNED ON

1. Check to see that the control power switch “reset light” is on and illuminated when the power is turned on.
2. Check all guards, covers, shields, interlocks and other safety devices for proper operation.
3. Check pressure gauges for proper readings
4. Check motors, gearboxes, and other parts for abnormal noises and report any to your supervisor.
5. After the initial set-up is completed, always make a trial run before starting production.

MACHINE OPERATION

1. Whenever a heavy workpiece must be moved, two or more persons should always work together.
2. When moving more than one work piece at a time or a stack of material, only trained, qualified and authorized workers should operate forklift trucks, overhead cranes, or other similar material handling equipment.
3. NEVER touch a work piece or adjust machinery in any way while the machine is running and/or operations are in process.
4. NEVER clean machine or remove dust and chips while the machine is in operation.
5. NEVER get into the path of material where the machine feeds the work piece through the operations.
6. NEVER attempt any operation or use any accessory not recommended by the manufacturer.
7. NEVER exceed specifications printed in the Technical Manual. Always use recommended or lower speeds and feeds. A higher speed can rip belts and/or damage work piece, and result in debris being hurled from the machine with violent force!
8. NEVER force the machine or work piece. The machine will do a better and safer job at the production rate for which it was designed.
9. Work only with approved materials.



NEVER stand directly in the path of parts being fed into and out of the machine. There is always danger of part “Kickback”.

TO INTERRUPT MACHINE OPERATION

When leaving the machine area temporarily for any reason, or changing the set-up, checking the alignment, or, adjusting or changing belts, etc., always turn off the main power supply switch on the electrical enclosure.



Refer to “LOCKOUT/TAGOUT PROCEDURE”, General Safety Precautions, page 1-6.

END OF OPERATION

1. Before leaving the machine for the day, or at the end of a shift, always turn off the power switch on the operator control panel and the main power supply switch on the electrical enclosure.
2. Always clean the machine and work area at the end of each job, end of each shift, or end of the day. Remove and dispose of chips, dust and other scrap, if necessary.

WARNING

When restarting the machine after it has been shut down, always assume that it has been tampered with. Recheck all settings for the job as though it were running for the first time.



For additional safety information and operating instructions, refer to “Operating Instructions” section found in this technical manual.

4. SAFETY INSTRUCTIONS FOR MAINTENANCE OF THIS MACHINE

1. Be sure that you have read and fully understand the maintenance and safety procedures found in this manual before servicing this machine.
2. High voltage is used to power this machine. Only authorized electricians should correct any electrical component failure.
3. Always disconnect main power supply and lock it in the “OFF” position before attempting any repair. Tag disconnect switch “DO NOT START MAINTENANCE OPERATION IN PROCESS.” The main circuit breaker should be turned off through out the operation!



Refer to “**LOCKOUT/TAGOUT PROCEDURE**”, **General Safety Precautions**, page 1-6.

4. Know the points where high voltages are present on this machine and in the electrical enclosures.
5. In the event of a power failure, turn off main power supply switch and circuit breaker immediately.
6. Always make sure that replacement fuses have the proper current rating.
7. Electrical components are protected from normal moisture resulting from humidity, use of water-based cleaners and lubricants, etc. *DO NOT use a water hose to wash or clean the machine, except where specially approved.*
8. The machine operator should never proceed with any maintenance procedure unless instructed to do so by his supervisor.
9. After the maintenance procedure is completed, the maintenance person should:
 - a. Remove all parts, tools and other loose objects from the machine and surrounding area before the operator resumes work.
 - b. Check to determine that the machine is operating safely.
 - c. Record the maintenance and inspection data for future reference.

⚠ WARNING

Residual voltages can exist in the electrical cabinets for a period of time after the power has been turned off and/or disconnected. Check any component with a voltmeter before touching.

⚠ WARNING

Abrasive belts continue to turn after power is turned off and/or disconnected. Always be sure that they have stopped turning completely before adjusting, changing or servicing.



For additional safety information and maintenance instructions, refer to the PREVENTATIVE MAINTENANCE, TROUBLESHOOTING, AND DISASSEMBLY/ REPAIR PROCEDURES found in this manual.

5. SAFETY INSTRUCTIONS DURING INSTALLATION OF THIS MACHINE

1. Be sure that you have read and fully understand the installation and safety instructions found in this manual.
2. Before moving the machine, verify the weight and be sure to use properly rated lifting equipment.
3. When the pre-installation checklist is completed, contact the factory or authorized service center to set up a time for the final installation and training.



For additional safety information and maintenance instructions, refer to the INSTALLATION INSTRUCTIONS found in this manual.



6. ADDITIONAL SAFETY INFORMATION FOR SANDERS

1. Read, understand and follow the safety and operating instructions found in this manual. Know the limitations and hazards associated with this sander.
2. Be sure to watch your hands on the following areas of the sander when operating.



3. Be sure to turn off the machine before performing any service or maintenance such as changing the abrasive belt.
4. Be sure that the machine is always electrically grounded.
5. Keep the floor around the machine clean and free of scrap material, dust, oil and/or grease to minimize the danger of slipping.
6. Be sure that the work area is well lighted and that a proper exhaust system is used to minimize dust. Be sure to provide an adequate workspace around the machine.
7. Check the air supply unit before starting the sander.
8. Be sure that the tension roller has tensioned the abrasive belt before starting the main spindle.
9. Keep sanding belt sharp and clean for safety and the best performance.
10. Always keep the sander dust free.



7. ADDITIONAL SAFETY INFORMATION FOR WET DUST COLLECTORS

1. Read, understand and follow the safety and operating instructions found in this manual. Know the limitations and hazards associated with this wet dust collector.
2. Be sure to watch your hands in the following areas of the wet dust collector when operating.



3. Be sure to turn off the machine before performing any service or maintenance such as cleaning.
4. Be sure that the machine is always electrically grounded.
5. Keep the floor around the machine clean and free of scrap material, dust, oil and/or grease to minimize the danger of slipping.
6. Be sure that the work area is well lighted and to provide an adequate workspace around the machine.
7. Motors and impellers continue to turn after power is turned off and/or disconnected. Always be sure that these parts have stopped turning before adjusting, changing, or servicing.
8. This machine WILL CONTAIN dust, and under certain conditions, sparks, that may lead to a fire or explosion hazard. Fire and explosion detection and suppression systems vary depending on what materials you are processing and using, and they are something that you must coordinate throughout your factory. Thus, you are solely responsible for determining what fire and explosion protection is necessary for your particular facility, including this machine, and you must supply any necessary fire and explosion detection and suppression equipment or systems.
9. After the control power switch has been turned off, check level in sight gauges and water level plate for proper reading.

con'td on next page



7. ADDITIONAL SAFETY INFORMATION FOR WET DUST COLLECTORS, cont'd.

10. Before leaving the machine for the day or at the end of a shift:
 - always turn OFF the power switch on the operator control panel, the main power supply switch on the electrical enclosure, as well as the main water supply, if auto level refill is used.

 - always wipe the machine and work area at the end of each job or shift.
11. When restarting the machine after it has been shut down, always assume that it has been tampered with and recheck all settings for the job as though it were running for the first time! Turn on water if auto level refill is used.
12. Do not use any detergent cleaners on the inside area of the dust collector. Foam will result in water being exhausted from the top of the dust collector.

8. SAFETY LABEL DOCUMENTATION

RULES FOR SAFE OPERATION

This manual uses the conventions shown below to emphasize critical or safety related information.

Do not soil, paint, alter, deface or remove any safety or operating procedure decals or placards from the machine. In the interest of your safety, we feel that it is important that all Midwest Sandright equipment in use, no matter how old, have up-to-date instructional decals and safety placards on the machine. If they are illegible or missing, order at once any individual decal or complete set free of charge by calling the Midwest Sandright Customer Service Department at (612) 721-5347 or toll-free at (800) 697-1444.

THE SAFETY ALERT SYMBOL



This is a safety alert symbol. It alerts the user to potential personal injury hazards. Obey all safety messages that follow this symbol to avoid possible injury or death.

THE SIGNAL WORDS

The safety alert symbol shown above is combined with three different signal words to indicate the nature of the hazard severity, as indicated below. These signal words are used in this manual and also on the safety labels attached to each machine.



DANGER - White letters with red background and red exclamation point.

This indicates an imminently hazardous situation which, if not avoided WILL result in death or serious injury.



WARNING - Black letters on a safety orange background with an orange exclamation point.

This indicates a potentially hazardous situation which if not avoided, COULD result in death or serious injury.



CAUTION - Black letters on a safety yellow background with a safety yellow exclamation point.

This indicates a potentially hazardous situation which if not avoided, COULD result in minor or moderate injury.



CAUTION - As above, without the safety alert symbol.

This indicates a potentially hazardous situation which if not avoided, COULD result in property damage.



Safety Label Kit - Bill of Material

Models DC 1200 & DC 1800



Indented Bill of Material

All Make Part Numbers, Ordered by PARENT PART NUMBER

UPPER(InBomm.fPartNo)+UPPER(InBomm.fcpartrev)=[4090046 000]

None, All Dates

Date: 02/18/2010

Time -13:28:39

Page # 1

Parent Part No 4090046

Rev 000

Effectivity Date / /

Description LABEL KIT, DC 1200 & 1800 *

Last Revision 03/04/2008

Level	Component Part No	Rev	Description	Quantity	U/M	Source
1	1038073	000	NAME PLATE, SANDRIGHT TAG	1.0000	EA	Stock
1	1038094	000	NAME PLATE, NIAGARA 3" X 24-1/2"	1.0000	EA	Stock
1	1044247	000	LABEL, HAZARDOUS VOLTAGE	1.0000	EA	Stock
1	1044256	000	SUGGESTED LOCKOUT PROCEDURE	1.0000	EA	Stock
1	1044257	000	SAFETY INSTRUCTIONS	1.0000	EA	Stock
1	1044260	000	LABEL, LOOSE ELECTRICAL CONNECTIONS	1.0000	EA	Stock
1	1044264	000	DANGER, ROTATING COMPONENTS	1.0000	EA	Stock
1	1044267	000	DUST & MATL COLLECTED FIRE HAZARD	2.0000	EA	Stock
1	1044271	000	ELEC.DISC.&OVERCUR PROVIDE BY OTHER	1.0000	EA	Stock
1	1044282	000	LABEL, DANGER "DO NOT REMOVE GUARD"	1.0000	EA	Stock
1	710000052	000	DECAL, 4" STRIPE RED AND GRAY	135.0000	IN	Stock
1	710000061	002	DECAL, M.W. SANDRIGHT 2.56" (RED)	1.0000	EA	Stock
1	710000063	000	DECAL, PROUDLY MADE IN USA	1.0000	EA	Stock

BOM Memo : Packs of 50

End Of Report

This report was requested by GLH

SAFETY LABEL KIT - ILLUSTRATED PARTS LIST

MODELS DC 1200 & DC 1800



Hazardous Voltage
1044247



Loose Electrical
1044260



Rotating Components
1044264



Fire/Explosion Hazard
1044267



Risk of Shock
1044271



Do Not Remove Guard
1044282

SAFETY INSTRUCTIONS

SUGGESTED LOCKOUT PROCEDURE

1. Announce lockout to other personnel.
2. Turn power OFF at main panel.
3. Lockout power in OFF position.
4. Put key in pocket.
5. Clear machine of all personnel.
6. Test lockout by hitting RUN button.
7. Block, chain or release stored energy sources.
8. Clear machine of personnel before restarting machine.
9. Take key from pocket.
10. Unlock the lockout device.
11. Turn power on at main panel.
12. Announce machine is ON to other personnel.

Suggested Safety Lockout Procedure
1044256



Nameplate, Midwest Sandright Tag
1038073



Name Plate, Niagara 3"
1038094

SAFETY INSTRUCTIONS

1. Read and understand the Operation Manual and all safety labels before operating this machine.
2. Only a trained person is to be permitted to operate this machine. Training should include instruction in operation under normal conditions and emergency situations.
3. This machine is to be serviced only by trained and authorized personnel. Follow lockout procedures before servicing.
4. Never reach into the machine for any reason unless the machine is at a COMPLETE STOP.
5. Never leave the machine stopped in such a manner that another worker can start the machine while you are working on or within the machine.
6. Never change or defeat the function of electrical interlocks or other machine "shutdown" switches.
7. Before starting this machine, check that:
 - All persons are clear of the machine.
 - No maintenance work is being performed on the machine.
 - All guards are in place.
8. There is a potential hazard of entanglement in this machine caused by items such as long hair, loose clothing, and jewelry. Make sure your clothing and hair fit closely to your body and that all jewelry, rings and watches are removed.

Safety Instructions
1044257



Decal, Midwest Sandright Red 2.56"
1038061

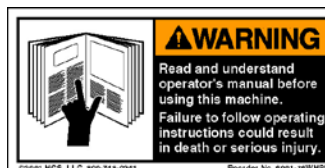

Read Manual
1044241

Decal, 4" Stripe Red & Gray
7100000052

Proudly Made In USA
7100000063

Safety Label Kit - Bill of Material

Models DC 2200 through DC 5500



Indented Bill of Material

Date: 02/18/2010
Time -13:29:08
Page # 1

All Make Part Numbers, Ordered by PARENT PART NUMBER

UPPER(InBomm.fPartNo)+UPPER(InBomm.fcpartrev)=[4090048 000]

None, All Dates

Parent Part No 4090048

Rev 000

Effectivity Date / /

Description LABEL KIT, DC 2200 THRU 5500 *

Last Revision 12/19/2007

Level	Component Part No	Rev	Description	Quantity	U/M	Source
1	1038073	000	NAME PLATE, SANDRIGHT TAG	1.0000	EA	Stock
			BOM Memo : mtl			
1	1038095	000	NAME PLATE, NIAGARA 4.5"	1.0000	EA	Stock
1	1044247	000	LABEL, HAZARDOUS VOLTAGE	1.0000	EA	Stock
1	1044256	000	SUGGESTED LOCKOUT PROCEDURE	1.0000	EA	Stock
1	1044257	000	SAFETY INSTRUCTIONS	1.0000	EA	Stock
1	1044260	000	LABEL, LOOSE ELECTRICAL CONNECTIONS	1.0000	EA	Stock
1	1044264	000	DANGER, ROTATING COMPONENTS	1.0000	EA	Stock
1	1044267	000	DUST & MATL COLLECTED FIRE HAZARD	2.0000	EA	Stock
1	1044271	000	ELEC. DISC. & OVERCUR PROVIDE BY OTHER	1.0000	EA	Stock
1	1044282	000	LABEL, DANGER "DO NOT REMOVE GUARD"	2.0000	EA	Stock
1	7100000052	000	DECAL, 4" STRIPE RED AND GRAY	200.0000	IN	Stock
1	7100000060	002	DECAL, M.W. SANDRIGHT 5.13" (METAL)	1.0000	EA	Stock
1	7100000063	000	DECAL, PROUDLY MADE IN USA	1.0000	EA	Stock
			BOM Memo : Packs of 50			

End Of Report

This report was requested by GLH

SAFETY LABEL KIT - ILLUSTRATED PARTS LIST

MODELS DC 2200 & DC 5500



Hazardous Voltage
1044247



Loose Electrical
1044260



Rotating Components
1044264



Fire/Explosion Hazard
1044267



Risk of Shock
1044271



Do Not Remove Guard
1044282

SAFETY INSTRUCTIONS

SUGGESTED LOCKOUT PROCEDURE

1. Announce lockout to other personnel.
2. Turn power OFF at main panel.
3. Lockout power in OFF position.
4. Put key in pocket.
5. Clear machine of all personnel.
6. Test lockout by hitting RUN button.
7. Block, chain or release stored energy sources.
8. Clear machine of personnel before restarting machine.
9. Take key from pocket.
10. Unlock the lockout device.
11. Turn power on at main panel.
12. Announce machine is ON to other personnel.

Suggested Safety Lockout Procedure
1044256



Nameplate, Midwest Sandright Tag
1038073



Name Plate, Niagara 4.5"
1038095

SAFETY INSTRUCTIONS

1. Read and understand the Operation Manual and all safety labels before operating this machine.
2. Only a trained person is to be permitted to operate this machine. Training should include instruction in operation under normal conditions and emergency situations.
3. This machine is to be serviced only by trained and authorized personnel. Follow lockout procedures before servicing.
4. Never reach into the machine for any reason unless the machine is at a COMPLETE STOP.
5. Never leave the machine stopped in such a manner that another worker can start the machine while you are working on or within the machine.
6. Never change or defeat the function of electrical interlocks or other machine "shutdown" switches.
7. Before starting this machine, check that:
 - All persons are clear of the machine.
 - No maintenance work is being performed on the machine.
 - All guards are in place.
8. There is a potential hazard of entanglement in this machine caused by items such as long hair, loose clothing, and jewelry. Make sure your clothing and hair fit closely to your body and that all jewelry, rings and watches are removed.

Safety Instructions
1044257



Decal, Midwest Sandright Red 5.13"
1038060

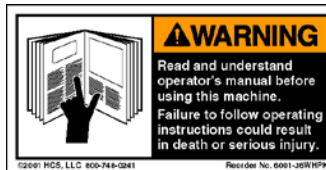

Read Manual
1044241

Decal, 4" Stripe Red & Gray
710000052

Proudly Made In USA
710000063

Section 2

Introduction



INTRODUCTION

Niagara Wet Dust Collection Systems come in a variety of models that are intended for safe, efficient collection of various dusts produced from grinding and deburring operations, using a water filled tank as the filter pulling the contaminated air. Dust particles sink to the base of the tank and are easily raked into a disposal container.

Materials suitable for wet collection include quick wetting and sinking dusts, materials of a combustible nature, applications where sparks may occur, or where mixing of material and various minerals occur, or in any application where particles are heavier than the specific weight of water.

Please call the Midwest Sales Department to discuss any needs.



WET DUST COLLECTOR BULLETIN



1. Machine Rotation. Dust collectors and blowers will pull air running in either rotation. Impeller can be manufactured in two configurations (see drawing). Use a flashlight and visually check from the front door looking upward.

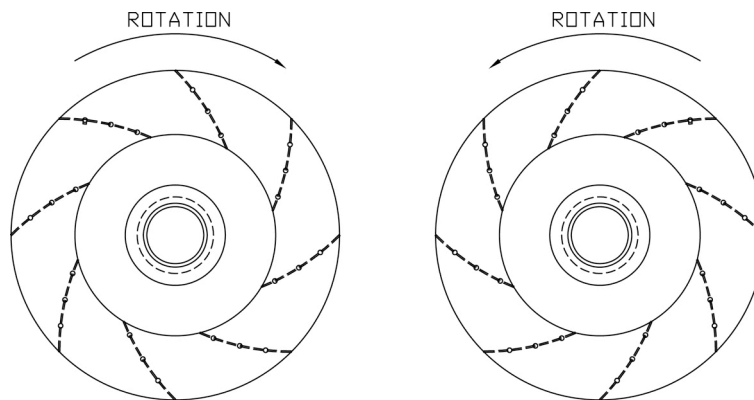

2. Sludge Disposal. Depending upon the types of materials being collected, refer to the various safety organizations, such as the Environmental Protection Agency, National Fire Protection Association, OSHA, and any regulatory organizations.

3. The dust collector has to be cleaned per instructions or the unit will not perform properly. If the collector does not perform properly, the piping and dust intakes will fill up with dust, which increases the risk of fire in the dust-generating equipment and piping.

4. Electrical connections. See NEC, OSHA and local codes for requirements. The collector must have a separate grounding wire run with the main power connections. The various fittings used to connect the collector and the dust-generating equipment must have a ground wire connecting them.

*Read the **Safety Directions** in Section 1 of this manual before operating this machine or performing preventative or general maintenance.*

*Always follow the **Lockout/Tagout Procedure** in “ Safety Directions, Section 1” found in this manual.*

TECHNICAL DATA & SPECIFICATIONS

Niagara Wet Dust Collectors

NIAGARA MODELS

Model DC1200

- Nominal air flow 1200 CFM
- Horse Power 3 HP (2.25 kW)
- Air inlet 6 inches (152 mm)

Model DC 1800

- Nominal air flow 1800 CFM
- Horse power 5 HP (3.75 kW)
- Air inlet: 7 inches (178 mm)

Model DC 2200

- Nominal air flow 2200 CFM
- Horse power 7.5 HP (5.5 kW)
- Air inlet 8 inches (203 mm)

Model DC 2800

- Nominal air flow 2800 CFM
- Horse power 10 HP (7.5 kW)
- Air inlet 10 inches (254 mm)

Model DC 3700

- Nominal air flow 3700 CFM
- Horse power 15 HP (12 kW)
- Air inlet 12 inches (305 mm)

Model DC 4700

- Nominal air flow 4700 CFM
- Horse power 20 HP (15 kW)
- Air inlet 12 inches (305 mm)

Model DC 5500

- Nominal air flow 5500 CFM
- Horse power 25 HP (19 kW)
- Air inlet 14 inches (356 mm)

NIAGARA Machine Configuration

- 230 volt/60 cycle/3 phase
- 380 volt/50 cycle/3 phase
- 460 volt/60 cycle/3 phase
- 575 volt/60 cycle/3 phase

ENGINEERING FLOOR PLAN

Refer to the Engineering Manual

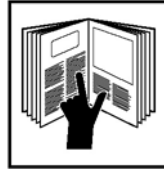

©2001 HCS, LLC 800-748-0241

LIMITED WARRANTY POLICY

Midwest warrants that it will, according to the following coverages, repair or replace, at its option, any component part of a Midwest machine that is found under normal operating conditions and prescribed maintenance to be defective in materials or workmanship, or that does not conform to the specifications set forth in the sales agreement. Warranty coverage begins on the ship date when shipped from Midwest or a distributor; or if the machine is installed by Midwest, at the completion of the installation or thirty (30) days from shipment, whichever comes first.

NEW MACHINE COVERAGE

One (1) Year Coverage

Any part that is defective will be repaired or replaced at Midwest's expense, including labor, for a period up to one (1) year. Warranty coverage excludes consumable parts and travel expenses.

Note: CONSUMABLE PARTS are items consumed in normal use, such as but not limited to membranes, chain pads, clutch plates, heater elements, fuses, filters, spray nozzles, saw blades, router bits, brushes, and abrasive media, are not covered by this warranty.

One (1) Year Prorated Coverage

Any wear part that is defective, where the life of the part is reduced over time through normal use, will be repaired or replaced at Midwest's expense, prorated over a one (1) year period of time. Warranty coverage excludes labor, travel, and freight. Wear parts include, but are not limited to, such items as drive belts, conveyor belts, contact drums, rubber coated rollers, chains, sprockets, heaters, and motor brushes.

Note: SILICONE SPREADING ROLLERS used in hot melt PUR roll coaters are specifically not covered under this warranty due to the extreme nature of typical applications. However, during the first thirty (30) days of operation, any silicone spreading roller that delaminates from the core, as determined by an inspection of our molded rubber supplier, and determined to be defective in materials or workmanship, will be resurfaced at Midwest's expense.

USED MACHINE COVERAGE

"Factory Reconditioned" Machine Coverage

Definition: Machines that have been completely reconditioned at the factory including new paint.

Coverage: Any part that is defective will be repaired or replaced at Midwest's expense for a period up to one (1) year. Warranty coverage excludes labor and travel expenses, and consumable parts.

"Factory Tested" Machine Coverage

Definition: Machines that have been functionally tested at the factory with all damaged and/or excessively worn parts replaced. Does not include new paint.

Coverage: Any part that is defective will be repaired or replaced at Midwest's expense for a period up to six (6) months. Warranty coverage excludes labor and travel expenses, and consumable parts.

"As-Is/Where-Is" Machine Coverage

Definition: Machines that are being offered in As-Is/Where-Is condition without factory testing.

Coverage: None.

REPLACEMENT PART COVERAGE

Any replacement part that is ordered from Midwest and found to be defective will be repaired or replaced at Midwest's expense for a period up to ninety (90) days, or for the remainder of the coverage for the original machine warranty, whichever is longer. Warranty coverage excludes consumable parts, labor and travel.

WARRANTY LIMITATIONS

• THE EXPRESS WARRANTIES MIDWEST MAKES IN THIS LIMITED WARRANTY POLICY ARE THE ONLY WARRANTIES MIDWEST WILL MAKE. THERE ARE NO OTHER WARRANTIES, WHETHER STATUTORY, ORAL, EXPRESS OR IMPLIED. IN PARTICULAR, THERE ARE NO IMPLIED WARRANTIES OF MERCHANTABILITY OR FITNESS FOR A PARTICULAR PURPOSE. The remedies provided in this LIMITED WARRANTY are Buyer's exclusive remedy for breach of WARRANTY.

• Customer waives any rights under this warranty, and Seller shall have no obligations under this warranty, if any portion of the purchase price remains unpaid or if Customer's account with Seller is in arrears.

- Product failures or defects caused by accidental damage, negligence, unreasonable use, misuse, abuse, or failure to maintain in accordance with maintenance schedules provided in an applicable Midwest Operating Manual, are not covered by this warranty.
- The warranty shall be null and void for any Midwest product, or component part, which is modified or altered in any way by any person not authorized by Midwest.
- Midwest is not responsible for, and will not pay for, work performed or repairs made by any other party unless prior written approval is obtained from Midwest.
- Midwest warrants only the mechanical performance of its sanding, deburring and finishing machines. Midwest cannot guarantee or warrant the life or performance of abrasive belts, brushes, or any other cutting, cleaning, or polishing media.
- For machines sold outside the U.S.A., warranty coverage does not include labor, freight, duty or taxes, or any travel or maintenance costs of personnel when a site visit is required.
- Midwest expressly limits its warranty responsibility or liability to the terms contained in the foregoing warranty provisions and in the Terms and Conditions Policy which are part of the sales agreement. Midwest expressly disclaims any liability for any compensatory punitive, special, incidental, or consequential damages, or any similar damages, whether foreseeable or not, arising from or related to any product failure.

WARRANTY CLAIM PROCEDURE

To initiate warranty service, contact the Midwest Customer Service department or the distributor that sold the machine. Notice of any warranty claim for a defective part must be received in writing within the warranty coverage time.

During the first year of the warranty, each package of warranty parts that weighs less than 150 pounds and is smaller than the UPS maximum package size of 165 combined inches (Length + 2x Width + 2x Height) will be shipped freight pre-paid using UPS. Packages weighing more than 150 pounds or being larger than such UPS size restrictions will be shipped freight pre-paid using LTL ground transportation. However, packages that exceed the UPS dimensions and that require expedited service or air freight or international shipment will be shipped freight collect on carriers chosen and arranged for by Midwest. Other than as specified above, the shipping terms and passage of title for parts shall be as provided elsewhere herein for Product(s). If a warranty determination cannot be made at the time the replacement part is ordered, or Midwest requires the part to be returned, the Customer must issue a purchase order and will be invoiced for the replacement part. A Return Materials Authorization (RMA) will be issued by Midwest for the return of the original part freight prepaid. Midwest will issue a credit memo when the original part is returned and found to be defective, provided it is received within thirty (30) days of the original part shipment.

Note: PARTS returned without a Return Materials Authorization (RMA) will not be accepted by Midwest.

LIMITS OF LIABILITY

Except as expressly set forth herein, Midwest shall not be bound by any representation, promise or inducement made by its agent or employee.

The remedies of Buyer set forth in this LIMITED WARRANTY POLICY are Buyer's exclusive remedies. The aggregate liability of Midwest for any claim of any kind for any loss or damage resulting from, arising out of or connected with this Agreement or from the performance or breach thereof, or from the manufacture, sale, delivery, resale, repair or use of any Product(s), whether based on contract, WARRANTY, tort (including negligence), strict liability, indemnity, or otherwise, shall in no event exceed the price allocable to the Product which gave rise to the claim. In no event shall Midwest be liable to Buyer or any other party for special, incidental or consequential damages of any nature, including but not limited to: Loss of profits, revenue or business opportunity; loss by reason of shutdown of facilities; loss because of inability to operate any machinery or facility at full capacity; damage to materials processed using the Product(s); and delamination of or defect in any product produced using the Product(s). The provisions of this paragraph shall supersede any inconsistent provisions in any document involving Buyer's purchase of Product(s) or forming a part of the purchase contract.

Customer assumes the sole responsibility for determining whether any particular Midwest product or system is suitable for the Customer's contemplated use, whether or not such use is known to Midwest. Customer assumes all risks and liabilities arising from the operation, performance and use of any Midwest product or system.

The Customer's exclusive remedy for breach of any Midwest warranty is repair or replacement of the defective Midwest item, whichever Midwest elects. In the event that a court determines that the sole remedies stated in and incorporated in the Terms and Conditions in any sales agreement between the parties have failed of their essential purpose, then Buyer's exclusive remedy for breach of any Midwest warranty shall be the return of the Product(s) freight prepaid, for refund of the purchase price less a depreciation/restocking charge of 2% per month.

Exclusive remedy for breach of any Midwest warranty shall be the return of the Product(s) in question, freight prepaid, for refund of the purchase price, less a depreciation/restocking charge of 2% per month or part thereof between (a) the time of delivery to Buyer under Incoterms or other terms specified in the Resulting Agreement and (b) receipt of the entire product(s) in question by Midwest at the premises designated by Midwest.

Section 3

Pre-Installation



PRE-INSTALLATION

The *Wet Dust Collector* will be shipped on a heavy wooded skid made of 4-inch by 6-inch timbers. When removing the machine from the truck, place your forks of the forklift between the three main timbers and lift up the front of the skid. Proceed to drag the machine out of the truck and place in a level area.

Now inspect the machine(s) for physical damage. If you see any damage, this must be noted on the Bill of Lading and initialed by the driver. You must then file a freight claim with the transportation company.

Check that the number of items received (pallets, skids, crates, boxes, etc.) matches the quantity on the Bill of Lading. If items are missing, it should be noted on the Bill of Lading and initialed by the driver. You then must file a freight claim with the transportation company.

Note: It is not the responsibility of Midwest Group One LLC companies to file a freight claim.

Before removing the machine from its skid, determine the location of the machine in your factory. The machine should be placed on a concrete slab, 4 inches or greater in thickness.

 **Check for correct voltage on serial plate before applying power!**

Connect the correct power to the disconnect in the electric box of the dust collector. Electrical connections should be made to the machine as specified on the schematic. *This should only be done by a qualified electrician and in accordance with all local and national codes.*

Check rotation of impeller after connecting electrical power. To change fan rotation, interchange any two of the power lines feeding the machine. Be sure that the power is disconnected first.

Pre-Installation Checklist

Refer to the following page for additional instructions and the Pre-Installation Checklist, which was also mailed under separate cover. Please sign and return the completed form, if the machine is to be installed by a Midwest Technician.



PRE-INSTALLATION CHECKLIST
Metal Division

COMPANY NAME: _____ CONTACT PERSON: _____
 ADDRESS: _____ TITLE: _____
 CITY, ST, ZIP/STATE: _____
 TEL: (_____) _____
 FAX: (_____) _____

MACHINES TO BE INSTALLED (MODEL #): _____

A. EQUIPMENT ARRIVAL CHECKLIST: BOX IF COMPLETED

1. Check machine(s) when received for physical damage. If notable or visible damage occurs, this must be noted on the Bill of Lading and initialed by the driver. You must also file a claim with the transportation company.

NOTE: IT IS NOT MIDWEST SANDRIGHT'S RESPONSIBILITY TO FILE A FREIGHT CLAIM.

• Was there any damage in shipment? NO YES (If yes, please see above)

2. Check the number of item(s) received (pallets, crates, containers, boxes, etc.) against the Bill of Lading to insure that no items are lost in transit. If item(s) are missing, it should be noted on the Bill of Lading and initialed by the driver. You must also file a claim with the transportation company.

NOTE: IT IS NOT MIDWEST SANDRIGHT'S RESPONSIBILITY TO FILE A FREIGHT CLAIM.

• Any item(s) missing in shipment? NO YES (If yes, please see above)

3. Verify that the Operating Manual(s) with Safety Directions have been received for each machine(s).

• Are the manual(s) received with machine(s)? YES NO

(If no, please list the machines by model number)

PRE-INSTALLATION CHECKLIST
SECTION B
ON REVERSE SIDE

3 - 3

Midwest Group One LLC • 2645 28th Avenue South • Minneapolis, MN 55406 USA
Tel. 612.731.5347 Fax. 612.731.8736 • www.midwestgroupone.com

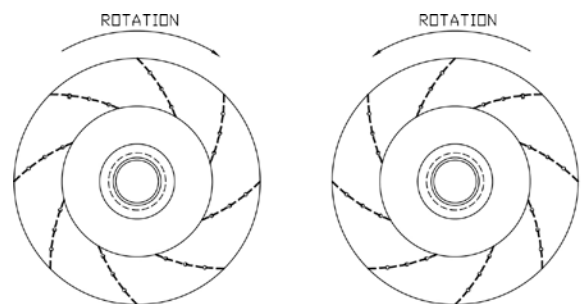

**PRE-INSTALLATION CHECKLIST
Metal Division**

COMPANY NAME: _____ CONTACT PERSON: _____
 ADDRESS: _____ TITLE: _____
 CITY, ST, ZIP/CODE: _____
 TEL: (_____) _____
 FAX: (_____) _____

MACHINES TO BE INSTALLED (MODEL #): _____

A. EQUIPMENT ARRIVAL CHECKLIST: ✓ BOX IF COMPLETED

1. *Check machine(s) when received for physical damage. If notable or visible damage occurs, this must be noted on the Bill of Lading and initialed by the driver. You must also file a claim with the transportation company.*

NOTE: IT IS NOT MIDWEST SANDRIGHT'S RESPONSIBILITY TO FILE A FREIGHT CLAIM.

• Was there any damage in shipment? No YES (If yes, please see above)

2. *Check the number of item(s) received (pallets, crates, containers, boxes, etc.) against the Bill of Lading to insure that no items are lost in transit. If item(s) are missing, it should be noted on the Bill of Lading and initialed by the driver. You must also file a claim with the transportation company.*

NOTE: IT IS NOT MIDWEST SANDRIGHT'S RESPONSIBILITY TO FILE A FREIGHT CLAIM.

• Any item(s) missing in shipment? NO YES (If yes, please see above)

3. *Verify that the Operating Manual(s) with Safety Directions have been received for each machine(s).*

• Are the manual(s) received with machine(s)? YES No

(If no, please list the machines by model number)

_____	_____
_____	_____
_____	_____
_____	_____

**PRE-INSTALLATION CHECKLIST
SECTION B
ON REVERSE SIDE**

B. PRE-INSTALLATION CHECKLIST: ✓ BOX IF COMPLETED

- 1. *Uncrate machine(s) and place in approximate location.* COMPLETED
- 2. *Supply electrical power to the machine(s).* NOT APPLICABLE COMPLETED
- 3. *Supply compressed air to the machine(s).* NOT APPLICABLE COMPLETED
- 4. *Supply dust collection to the machine(s).* NOT APPLICABLE COMPLETED
- 5. *Provide an industrial grade hammer drill and drill bits suitable for anchoring the machine(s) to concrete.* AVAILABLE
- 6. *Provide adequate supply of materials for the installation and training, including sample abrasives.* AVAILABLE
- 7. *Contact person responsible for start-up of machine(s)* Name: _____
 - *Is contact person experienced with this type of machine(s)?* YES NO
 - *Will contact person be available at all times during installation and training?* YES NO
- 8. *Other employees to be trained:* Name: _____ Title: _____
Name: _____ Title: _____
Name: _____ Title: _____
Name: _____ Title: _____
- 9. *What are your normal working hours?* _____AM to _____PM
 - *Are you available to work after hours if it will aid in the installation?* YES NO
 - *Are you available to work weekends if it will aid in the installation?*
Saturday YES NO
Sunday YES NO

**NOTE: THERE IS AN OVERTIME PREMIUM FOR SATURDAY, SUNDAY AND HOLIDAYS.
PLEASE SEE MIDWEST'S INSTALLATION & SERVICE POLICIES FOR DETAILS.**

COMMENTS: _____

CUSTOMER VERIFIES THAT THE ABOVE REFERENCED ITEMS HAVE BEEN COMPLETED OR OTHERWISE NOTED, AND THAT THE MACHINE(S) MEET(S) LOCAL CODES AND IS NOW READY FOR INSTALLATION.

Signed: _____
(CUSTOMER)
TITLE: _____
Date: _____

THE INSTALLATION WILL BE SCHEDULED UPON COMPLETION OF THIS DOCUMENT
PLEASE SIGN AND RETURN THIS FORM VIA MAIL OR FAX TO MIDWEST SANDRIGHT

**ATTN: JERRY SCHLUMBERGER, CUSTOMER SERVICE MANAGER
MIDWEST GROUP ONE LLC
2645 26TH AVE SOUTH • MINNEAPOLIS, MN 55406 USA
TEL (612) 721-5347 • FAX (612) 721-1736**

Section 4

Installation



PREPARATION FOR INSTALLATION OF A DUST COLLECTOR

1. Decide location for new collector.
 - a. Location should be a covered building to prevent the unit from getting wet, unless unit is equipped for outdoor use.
 - b. If in a colder climate, the collector has to be kept in a heated facility.
 - c. If you are unsure of the above, please contact Midwest Sandright at tel. 612-721-5347 or fax. 612-721-1736 or email: service@midwestgroupone.com
2. Locate and install correct size main disconnect on the wall near the collector location. (Check electrical codes for proper specifications.)
 - a. The collector comes pre-wired with a magnetic starter and thermal overload, wired with 110 volt controls.
 - b. You should always have a main disconnect switch of the correct size leading to the collector. This should be done according to local electrical codes and standards.
 - c. Common motor sizes and amperage chart.
Note: Other voltages available upon request.

<u>HORSEPOWER</u>	<u>VOLTAGE</u>	<u>AMPERAGE</u>	<u>RECOMMENDED MINIMUM DISCONNECT RATING (AMPS)</u>
3	230	7	10
3	460	8.8	5
5	230	11.4	15
5	460	5.7	10
7.5	230	17.2	20
7.5	460	8.6	10
10	230	24	30
10	460	12	15
15	230	34.2	40
15	460	17.1	20
20	230	46	55
20	460	23	30
25	230	63	80
25	460	31.5	40



NOTE: A separate ground wire should be run to the dust collector. Conduit ground is not acceptable. (This will help to minimize any possibility of static electricity build-up.)

3. Have a plumber locate the water line with shut-off valve near the collector location.
4. If the discharged air from the collector is to be expelled outside of the building, have holes roughed in going through the roof or wall.
5. Order the correct ductwork made with radii for connecting machinery to the wet collector. If unsure, please contact our customer service dept.
6. Plumb water from shut-off valve to water connection on the solenoid valve located on the side of the machine. Low volume of water is required.
Refer to Figure 1.

Fig. 1

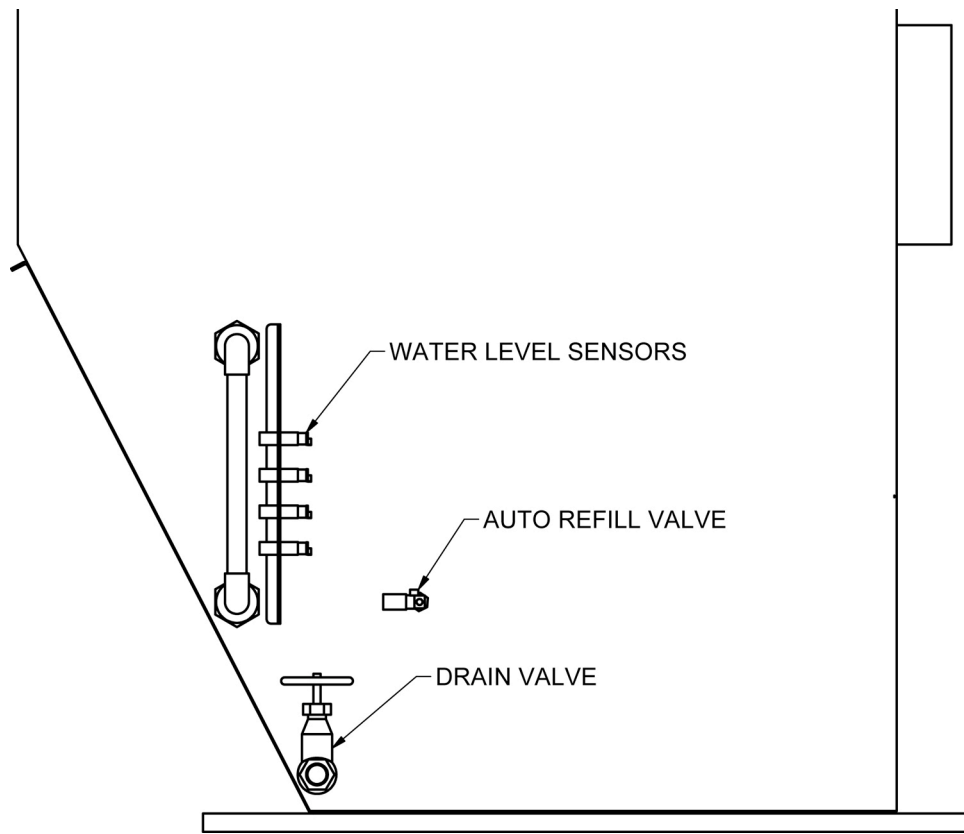

APPROXIMATE WATER CAPACITY

SMALL	DC 1200/1800	75 GALS.
MEDIUM	DC 2200/2800	160 GALS.
LARGE	DC 3700/4700/5500	225 GALS.

FILLING THE COLLECTOR WITH WATER

All collectors are equipped with an auto level refill.

CAUTION Do not adjust the water level when the unit is off.
This will result in over filling and flooding of the floor.

Water level sensors can be adjusted by loosening the lock nut and sliding the sensor to the desired location on the sight glass tube, and re-tightening the lock nut.

Why the water level is critical. Refer to Figure 2.

The water level is critical to the function of the collector. If the water level is too low, the water will blow through the unit and it will not separate the dust from the air.

If the water level is too high, it will cut down on the amount of air being pulled. The motor will also draw higher amps than normal causing the thermal overload to drop out on the magnetic starter.

4. Fill the tank with water until the water can be seen on the level gauge. The water level gauge is checked without the collector running. Always start with the water level at zero (0). It can easily be increased or decreased from this point, as needed.

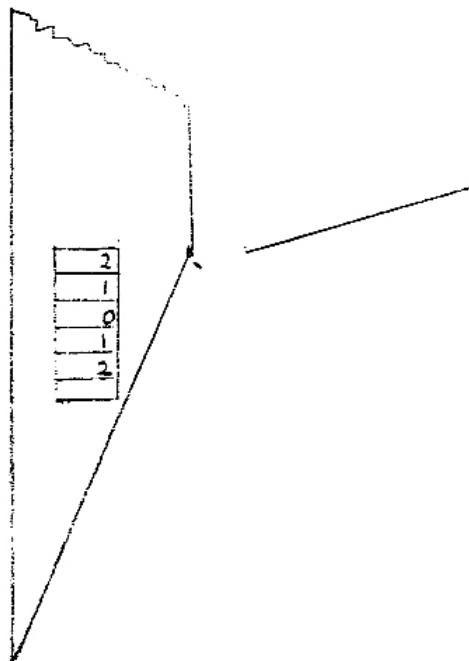

Water level: Checked
with machine not running.
Zero is the starting level.

Fig. 2

CONNECTING THE COLLECTOR TO THE OTHER MACHINES



Take care to use the correct pipe layout and elbow radii for optimum C.F.M. It is recommended that the ductwork be made of welded pipe and flanged construction. The joints should also be put together with fire retardant joint seal. Call the Midwest Sandright Customer Service team for assistance at 612-721-5347 or 1-800-697-1444 for proper piping sizes and layout.

NFPA Instructions and Regulations –

See NFPA484 for interlocking to dust producing equipment instructions.

STANDARD SPIRAL PIPE DUCTWORK PACKAGES FOR USE WITH MODELS 1200/1800/2200/2800

Made of spiral pipe and elbows. Intended to be connected to most single head exhaust inlet machines. Midwest recommends that the collector is placed no further than 10-feet away from the machine it is connected to. With this in mind, it comes with piping to be placed within the 10-foot space or less. For shorter runs, the straight runs are easily cut to shorten the distance. Components include spiral pipe and 90° elbows.

PIPE KIT INSTRUCTIONS

Place the dust collector within 10-feet from the widebelt sander, then proceed with the following steps. See *Figure 3, next page*.

Step 1

Mount an elbow pointing upwards from the flanged adapter on the dust collector.

Step 2

Mount the second elbow to the top of the widebelt sander, facing the dust collector.

Step 3

Measure from the floor to the top of the machine-mounted elbow, and subtract the distance from the floor to the top of the elbow mounted in Step 1. Cut a piece of straight pipe to this length and mount it to the elbow on the dust collector.

Step 4

Mount an elbow to the top of the pipe mounted in Step 3, pointing to the elbow on the top of the widebelt sander.

Step 5

Measure the distance between the elbows and cut the remaining straight pipe to this length. Mount between elbows.

Step 6

Mount a separate ground wire from the dust collector to the dust-generating machine.



Note: Wear gloves, as the cut ends of the ducting may be sharp. All duct work fittings should be connected with sheet metal screws and sealed.

Fig. 3

Note: Pipe kit can be adapted to work with various single inlet machines.

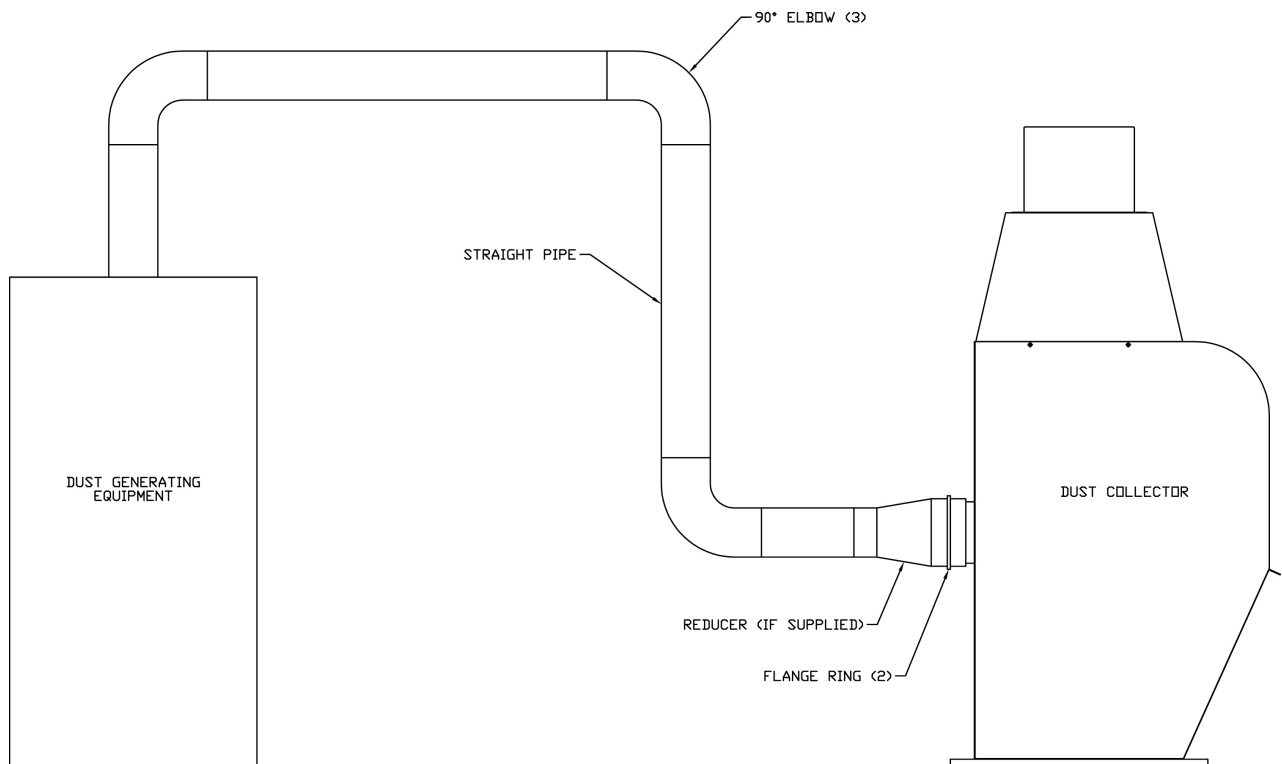

Specifications are subject to change without notice.

Section 5

Operation



OPERATION

1. Fill the tank with water until the water can be seen on the level gauge. The water level gauge is checked without the collector running. Always start with the water level at zero (0). It can easily be increased or decreased from this point, as needed.



Note: Use plain water only. Never use any additives as they can create foam which will prevent the dust collector from filtering the air.

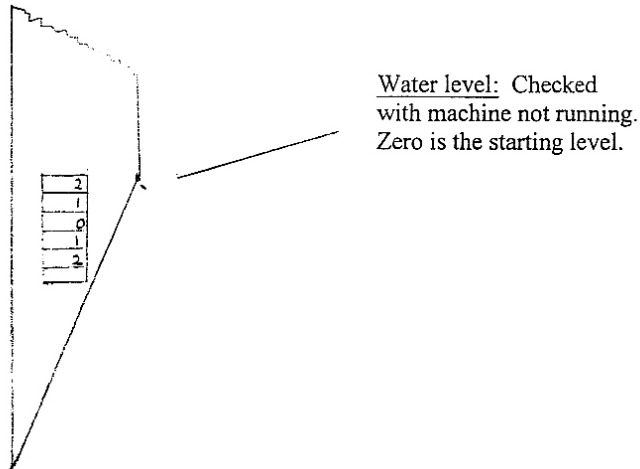

2. Turn the water supply OFF at this time.
3. After the unit is piped to the dust-generating machine, remove the front door. Jog the motor on and off briefly. Using a flashlight, look up at the impeller. Match the proper rotation per the following drawing.

Note: Swap two leads of incoming power to reverse motor rotation.

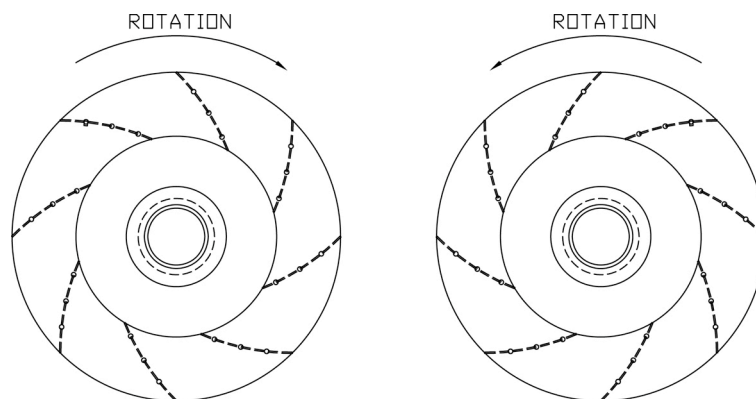

When rotation is correct, replace the door.

4. Turn the dust collector ON and watch the water level. It will drop substantially.

Proper operating level should have the water above the bottom of the door by at least 1-inch. This level will vary by model and other installation components.

5. At this time let the unit run for 15-20 minutes.
Recheck the water level WHILE RUNNING. It should be at least 1-inch or more above the bottom of the door.

6. Set the auto level refill sensors at this time.

The lower sensor should be set so it starts adding water when the water level is about 1" above the bottom of the door.

The upper sensor should be set so it stops adding water when the water level about 3" above the bottom of the door.

Note: Different applications will require slightly different settings.

Section 6

Scheduled Maintenance



SCHEDULED MAINTENANCE



Read the Safety Directions in Section 1 of this manual before performing maintenance work. Always follow the Lockout/Tagout procedures.

1. SLUDGE REMOVAL

- a. The sludge will have to be removed a minimum of once every 8 hours. In heavy stock removal applications, you will have to set a sludge removal schedule that fits your application.
- b. Collected sludge should not be put in a sealed container.
- c. Be sure the sludge does not build up on the unit's sides and baffles. If this does occur, they should be cleaned.
- d. The usual cleaning of the unit is as follows:
 1. Sludge is scooped out at least every 8 hours.
 2. The baffles and sides of the unit should be cleaned at the same time the hopper is scooped out.
 3. The small particle grids should be removed and cleaned regularly. They have a direct effect on the unit's performance. (The grids are located in the center of the machine's water cabinet and easily lift out.)
- e. Follow recommended NFPA (National Fire Protection Assoc.) and EPA (Environmental Protection Assoc.) codes that apply to the materials being collected.
 1. N.F.P.A. 480 - Storage, Handling and Processing of Magnesium.
 2. N.F.P.A. 69 - Explosion Prevention Systems
 3. N.F.P.A. 481 - Production, Processing, Handling and storage of Titanium
 4. N.F.P.A. 651 - Manufacture of Aluminum Powder
 5. N.F.P.A. 65 - Processing and Finishing of Aluminum

Others may apply to your specific application.

2. SPARE PARTS

- a. When calling for parts, always have the following information:

YOUR MACHINE MODEL# AND SERIAL #

3. DISCHARGE OUTLET PIPES

- a. These pipes have to be larger than inlets to minimize back pressure.
- b. They should also be to the side, not the top, to minimize condensation build-up, if being used any other way than the standard machine design.
- c. Please contact Midwest Sandright. for the proper sizing and layout of discharge ducts.

4. GENERAL APPLICATION INFORMATION

There are different sizes of wet collectors that are identical in principle and similar in construction. All models are supplied with auto level refill valves that are also identical in principle and similar in construction. These are fitted on the side of the unit. Description and instructions refer to all sizes of dust collectors.

The suitability of the wet dust collector for an application is determined by the type of dust to be exhausted.

<u>Suitable</u>	<u>Not Suitable</u>
Quick wetting dust	Non-wetting dust
Quick sinking dust	Dust that floats, even when shaken vigorously in a bottle of water
Dust of a combustible nature where sparks may occur such as metallic dust, exhaust from abrasive grinding	Very fine dust (see note below)



Note: Although dust is very fine, sometimes it is necessary to use a wet dust collector due to risk of fire or explosion, or for convenience or safety of dust removal. In these cases, the exhausted air should be vented outside.

Separate, specific options should be used for magnesium and certain aluminum. These units should be modified and the ducting specially designed to meet specific safety guidelines and codes.

5. SLUDGE DISPOSAL

Depending upon the types of materials being collected, you may have to refer to the various safety organizations: Environmental Protection Agency, National Fire Protection Association, O.S.H.A. (Occupational Safety and Health Act) and any other local regulatory organizations.

EXAMPLES:

- a. N.F.P.A. 480 - Storage, handling and processing of Magnesium
- b. N.F.P.A. 69 - Explosion prevention systems
- c. N.F.P.A. 481 - Production, processing, handling and storage of Titanium
- d. N.F.P.A. 651 - Manufacture of aluminum powder
- e. N.F.P.A. 65 - Processing and finishing of aluminum

Never put the removed sludge in a sealed container. Some materials that are collected may give off gases while drying. The sludge should be stored in a well-vented area, to prevent excess gases from building up.

Always check with local authorities in your area for proper disposal and handling instructions.

Cleaning and care of the collector:

The unit should be cleaned on a regular basis.
(A minimum of every 8 hours.)

Remove any sludge from the bottom of the hopper and any build-up that occurs in the filters or sides of the collector.

Section 7

Replacement Parts Installation





Read the **Safety Directions** in Section 1 of this manual before operating this machine or performing preventative or general maintenance.

WARNING

Follow the **Lockout/Tagout Procedure** in Section 1, page 1-6 of the Safety Directions.

Got a question? Need a part? Service call?

Contact Customer Service, Monday - Friday, 8:00 AM to 4:30 PM CST

- ①  Tel: 1-612-721-5347 or 1-800-697-1444
- ②  Email: service@midwestgroupone.com
- ③  Fax: 1-612-721-1736

It's as easy as 1-2-3

Section 8

Troubleshooting



TROUBLESHOOTING

WARNING

Electrical work, especially work in an electrical enclosure with the power on, should only be done by a qualified electrician.

Typical Problems

The procedures in this section are meant to help customers solve problems. Additional help is available over the phone by calling the Midwest Customer Service at 1-800-697-1444.



Incorrect water level and foaming are the two most common causes of problems. Refer to the following chart or Section 4, "Installation" for more information.

Problem: Dust collector will not start

- | | |
|-----------|---|
| Cause: | Power not connected |
| Solution: | Have qualified electrician connect the power, following all applicable codes |
| Cause: | Main fuses blown |
| Solution: | Determine the reason, such as incorrect voltage connected to the dust collector, overload, power surge, etc. Correct. Replace fuses |

Problem: Dust collector starts, but shuts off after a minute

- | | |
|-----------|---|
| Cause: | Overload tripping |
| Solution: | Water level is incorrect
Correct water level
Reset overload |
| Solution: | Incorrect impeller rotation
Change rotation of impeller
Reset overload |
| Solution: | Airflow is incorrect.
Adjust flow meter in ducting, if installed
Reset overload |
| Solution: | Overload set too low
Set dial on overload to rated FLA of motor
Reset overload |

Problem: Odor

- | | |
|-----------|----------------------------|
| Cause: | Foul water |
| Solution: | Drain and clean thoroughly |

Problem: Dust discharging from top of unit

Cause: Water level is too low
Solution: Add water

Cause: Foaming causing carry-over of sludge
Solution: Contact Midwest Customer Service for anti-foam additive

Cause: Particle grid is plugged
Solution: Clean and wash out

Problem: Water discharged from unit and/or leaking from machine

Cause: Water level is incorrect – usually too low
Solution: Add water

Cause: Baffles require cleaning
Solution: Clean and wash out

Cause: Foaming
Solution: Contact Midwest Customer Service for anti-foam additive

Problem: Insufficient suction at dust-generating equipment

Cause: Water level is too high; connections may be clogged
Solution: Clean all duct pipes and adjust level

Cause: Unit may be too small for application
Solution: Contact Midwest Customer Service

Cause: Fan running backwards
Solution: Check impeller rotation

Cause: Blockage somewhere in the system
Solution: Check inlet and outlet for possible blockage location

Problem: Surging water level

Cause: Water level is too high OR too low
Solution: Adjust water level

Cause: Foaming
Solution: Check water level
Determine what material is causing the problem

Section 9

Recommended Spare Parts List



RECOMMENDED SPARE PARTS

Wet Dust Collection System

Models 1200

Part Number	Description	Qty
1509800153	Impeller	1
1502500515	Bushing TaperLoc, 7/8"	1
1504400155	Stainless Mist Eliminator, 18" x 26" x 2"	1

Models 1800

Part Number	Description	Qty
1509800095	Impeller	1
1502500511	Bushing TaperLoc, 1-1/8"	1
1504400155	Stainless Mist Eliminator, 18" x 26" x 2"	1

Models 2200

Part Number	Description	Qty
5643337	Impeller	1
1502500511	Bushing TaperLoc, 1-1/8"	1
1504400156	Stainless Mist Eliminator, 24.5" x 33.5" x 2"	1

Models 2800

Part Number	Description	Qty
1509800105	Impeller	1
1502500510	Bushing TaperLoc, 1-3/8"	1
1504400156	Stainless Mist Eliminator, 24.5" x 33.5" x 2"	1

Models 3700

Part Number	Description	Qty
5643338	Impeller	1
1502500510	Bushing TaperLoc, 1-3/8"	1
1504400156	Stainless Mist Eliminator, 24.5" x 33.5" x 2"	1

Models 4700

Part Number	Description	Qty
1509800144	Impeller	1
1502500516	Bushing TaperLoc, 1-5/8"	1
1504400156	Stainless Mist Eliminator, 24.5" x 33.5" x 2"	1

Models 5500

Part Number	Description	Qty
5643336	Impeller	1
1502500516	Bushing TaperLoc, 1-5/8"	1
1504400156	Stainless Mist Eliminator, 24.5" x 33.5" x 2"	1

Section 10
Illustrated Parts List



ILLUSTRATED PARTS LIST

Refer to the Engineering Manual

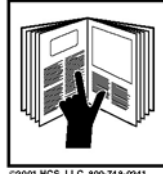

©2001 HCS, LLC 800-748-0241

Section 11
Schematics & Programs



ENGINEERING DOCUMENTS

Refer to the Engineering Manual

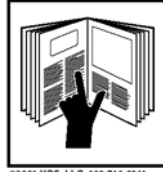

©2001 HCS, LLC 800-749-0241

Section 12

Vendor Information



VENDOR INFORMATION

Not Applicable To This Model Number

HOW TO REACH US - METAL DIVISION

Midwest Sandright

2645 26th Avenue South
Minneapolis, MN 55406
www.midwestgroupone.com

 **Tel:** 612.721.5347

 **FAX:** 612.721.1736

 **EMAIL:** sales@midwestgroupone.com

Sales & Marketing Team

Kenneth P. Holley • President
kholley@midwestgroupone.com
612.721.5347

Gary Haider • VP Sales
ghaider@midwestgroupone.com
direct: 612.843.1365

Tim Martin • Senior Specialist, Metal Division
tmartin@midwestgroupone.com
direct: 612.843.1343

Carole H. Brueggeman • Marketing/Media Manager
chb@midwestgroupone.com
marketing@midwestgroupone.com
direct: 612.843.1331

Parts & Service

toll-free: 800.697.1444
service@midwestgroupone.com

Bob Benson • Service Manager
bbenson@midwestgroupone.com
direct: 612.843.1312

Jerry Schlumpberger • Customer Service Manager
jschlumpberger@midwestgroupone.com
direct: 612.843.1311

