



Dantherm[®]

Filtration

Formerly DISA Systems Inc.

DANFOSS VLT 6000 HVAC DRIVE QUICKSTART INSTRUCTIONS (FIELD WIRING, SCHEMATICS AND PARAMETER SETUP)

ATTENTION !!

Before starting to wire the panel read through all of these instructions first. If you have any questions please call the toll free number below.

After wiring the panel **DO NOT** apply power until all wiring has been double checked - any incorrect wiring can cause severe damage to the drive's computer and will void any warranties.

1-800-533-5286

Dantherm Filtration, Inc.
102 Transit Ave.
PO Box 429
Thomasville, NC 27361-0429
Telephone: (800) 533-5286
Fax: (336) 821-0890
www.danthermfiltration.com

If in doubt about the electrical schematics or drive instructions, please call Dantherm Filtration electrical department at the above number.

Warning: No portion of this manual may be reproduced in any shape or form without the written approval of Dantherm Filtration, Inc. Revised 3/20/06.

DANFOSS VLT6000 HVAC MOTOR DRIVE

Field Wiring Instructions:

Check the relevant drawing for your configuration in the back of this document for the correct hook up. Usage of relay #1, relay #2 and the 4-20ma pressure transducer is system dependent.

1. Main Power

Connect the three incoming power wires to terminals 91, 92 and 93.

Use the gage wire which will match the horsepower rating of the motor.

Phase 1 to L1 (terminal 91)

Phase 2 to L2 (terminal 92)

Phase 3 to L3 (terminal 93)

Connect the green wire to the drives chassis.

2. Relay #1 (Alarm contacts - output from drive)

Connect Relay #1 from the Danfoss drive to the control panel as follows:

Terminal 01 of drive to terminals 2 and 3 of the Dantherm control panel's filter fan interface.

Terminal 02 of drive to terminal 4 of the Dantherm control panel's filter fan interface.

3. Relay #2 (Run contacts – output from drive)

Connect Relay #2 from the Danfoss drive to the NF-8HD control panel as follows:

Terminal 04 of drive to terminal E1 of NF-8HD.

Terminal 05 of drive to terminal E2 of NF-8HD.

4. Optional 4-20ma pressure transducer – (Closed Loop Operation)

(refer to the “DWYER PRESSURE TRANSDUCER TO DANFOSS VLT 6000 HVAC DRIVE HOOK UP” schematic)

Connect the optional pressure transducer to the motor drive as follows:

Terminal 12 of drive to the + input of the pressure transducer.

Terminal 60 of drive to the 4-20ma output of the transducer.

Connect Terminal 39 of drive to Terminal 55 of drive. This satisfies the ground requirements for the drive.

5 Motor

Make sure the operating voltage of the motor matches the output voltage of the drive.

Connect the motor to the the U, V and W terminal of the drive as follows:

Terminal 96 of drive to phase 1 of the motor

Terminal 97 of drive to phase 2 of the motor.

Terminal 98 of drive to phase 3 of the motor.

6. Control wiring

Enable signal (mandatory jumper for drive operation)

Wire a jumper from Terminal 12 of the drive to Terminal 27 of the drive.

Start signal (start command from Dantherm control panel)

Connect Terminal 12 of drive to Terminal 5 of the control panel filter fan interface.

Connect Terminal 18 of drive to Terminal 6 of the control panel filter fan interface.

LOCAL CONTROL PANEL (LCP)

The LCP is a complete interface for operating and programming the drive.
The functions of the control panel are:

- 1) Display.
- 2) Keys for changing display mode.
- 3) Keys for changing program parameters.
- 4) Indicator lamps.
- 5) Keys for local operation.

LOCAL CONTROL PANEL (LCP) KEYPAD

(refer to fig.1 for interface layout)

Display Mode: Used for selecting the indication mode of the display or when returning to the Display mode from either the Quick menu or the Extend mode. Pressing and holding this button will show the units of the readouts.

Quick Menu: Gives access to the twelve parameters used in the Quick Menu section.

Extend Menu: Gives access to all parameters.

- Change Data:** Used for changing parameters in Quick or Extend Menu modes.
- Cancel:** Parameter change will not occur if this button is depressed.
- OK:** Confirms a change of a selected parameter.
- Up/Down arrows:** Used for selecting or changing parameters.
- Right/Left arrows:** Used for selecting parameter groups or moving the cursor when changing numerical values.
- Hand Start:** Initiates a manual start command.
- Off Stop:** Stops the motor.
- Auto Start:** Allows drive to be controlled externally via control signals or serial communication.
- Reset:** Resets drive in the event of an alarm trip.

LOCAL CONTROL PANEL (LCP) PARAMETER ENTRY (Refer to the correct parameters page for the parameter list)

Drives can be operated in “Closed Loop” or “Open Loop”. Make sure all the entered parameters match your application.

BEGIN ENTERING PARAMETER DATA.

QUICK MENU (12 Parameters)

Press “Quick Menu”. Use the “+ and –“ arrow keys to select parameter number. When the parameter is found, press “Change Data” and use the four arrow keys to manipulate the parameter. When satisfied, press “OK”.

EXTENDED MENU

Press “Extend Menu”. Use the “right and left” arrow keys to find the parameter group (0 thru 6). When the group is found, use the “+ and –“ arrow keys to select one of the many parameters within the group. Press “Change Data” and use the four arrow keys to manipulate the parameter. When satisfied, press “OK”.

Example: *Change setpoint 1 (parameter 418) to 10” of water column.*

Press the ‘Extend Menu’ button to gain access to all parameters.

Press the ‘Right Arrow’ key multiple times to access ‘4.. Appl. Functions’.

Press the ‘Up arrow’ key multiple times to access parameter 418.

Press the 'Change Data' key.

Use the four 'Arrow keys' to change the data to the desired setting. In this example it will be 10.

Press 'OK'. This will lock the setting. If you don't do this, your setting will not take. If you made a mistake, pressing 'Change Data' will allow you to correct your mistake. Press 'OK' once again to accept changes.

Press "Auto Start" to start drive if it isn't running already.

When you are finished entering or editing parameters, press "Display Mode" to properly display the variables on the LCP that were entered in parameters 007 thru 010.

MOTOR ROTATION

Before performing this test, the following must be true:

- 1) All parameters on the "Quick Menu" and Extended Menu" parameters list must be entered completely and correctly.
- 2) Supply voltage, drive voltage and motor voltage must agree!

Begin by applying power to the drive.

Press "Hand Start" immediately followed by "Off Stop" on the LCP. This should allow you enough time to check the rotation of the coasting motor. If the motor doesn't start press "Display Mode" to find the screen that says "USE +/- " in the upper left hand corner. Press the "Up Arrow" to increase the frequency output of the drive. Repeat the rotation check by pressing "Hand Start" followed by "Off Stop".

DRIVE OPERATION

(closed loop operation – externally enabled)

All steps prior to this must be completed successfully for the drive to be externally enabled. Press "Auto Start" on LCP to enable drive to be externally controlled. At this point the drive should not run until it receives an ENABLE signal from the control panel. Parameter 418 or Setpoint 1 determines the frequency of operation based on a feedback signal. See the example above to change this value.

(open loop operation – externally enabled)

This mode closely mimics a soft start. The difference being, the final frequency of operation is programmable. Parameter 201 (Frequency Lower Limit) determines the frequency of the drive. This parameter will have to be changed to a value which will satisfy system requirements. To change this value press "Quick Menu". Press the "up" arrow until parameter 201 is reached. Press "Change Data". Use the left and right arrows to select the unit and the up and down arrows to change the value. After entering the new value press "OK". This will store the value. Finally, press "Auto Start" which will ramp the drive to the new value if this button hasn't been pushed previously.

(open loop operation – keypad control)

Pressing the “DISPLAY MODE” switch quickly will switch to different screens. Find the screen that says “USE +/- ” in the upper left hand corner. Press “HAND START”. The motor should start. If it doesn’t, press the “+” key until the desired speed is reached. Conversely, pressing “-“ will slow the motor down. The value indicated is a percentage of the operating speed between min. and max. frequency values.

OPEN LOOP PARAMETERS

(soft start emulation)

QUICK MENU PARAMETERS

001	Language	English
102	Motor Power	Motor Plate
103	Motor Voltage	“ “
104	Motor Frequency	“ “
105	Motor Current	“ “
106	Motor Nom. Speed	“ “
201	Frequency Lower Limit	12 – Determines the frequency of operation
202	Frequency Upper Limit	60
206	Ramp Up Time	System Dependent
207	Ramp Down Time	“ “
323	Relay 1 Function	Alarm
326	Relay 2 Function	Run

EXTENDED MENU PARAMETERS

007	Large Readout	Power [kW]
008	Small Readout 1	Reference [unit]
009	Small Readout 2	Feedback [units]
010	Small Readout 3	Frequency [Hz]
100	Configuration	OPEN LOOP
204	Min. Reference	0
205	Max. Reference	60
402	Flying Start	Enable
413	Min. Feedback	0
414	Max. Feedback	100
415	Ref./Fbk unit	(%1)

DANFOSS VLT 6000 HVAC CLOSED LOOP PARAMETERS

(drive controlled by 4-20ma pressure transducer)

QUICK MENU PARAMETERS

001	Language	English
102	Motor Power	Motor Plate
103	Motor Voltage	“
104	Motor Frequency	“
105	Motor Current	“
106	Motor Nom. Speed	“
201	Frequency Lower Limit	System Dependent
202	Frequency Upper Limit	“ “
206	Ramp Up Time	“ “
207	Ramp Down Time	“ “
323	Relay 1 Function	Alarm
326	Relay 2 Function	Run

EXTENDED MENU PARAMETERS

007	Large Readout	Power [kW]
008	Small Readout 1	Reference [unit]
009	Small Readout 2	Feedback [units]
010	Small Readout 3	Frequency [Hz]
100	Configuration	CLOSED LOOP
204	Min. Reference	Same as Par.413
205	Max. Reference	Same as Par.414
314	Terminal 60	Feedback
315	Term.60 Lo Scale	4
316	Term.60 Hi Scale	20
402	Flying Start	Enable
413	Min. Feedback	0
414	Max. Feedback	15
415	Ref./Fdbk unit	inches of wg
418	Setpoint 1	0 thru 15in. – Determines the frequency of operation
423	PID Proportional Gain	.1 thru 1 – “ “
424	PID Integration Time	1 thru 2 sec. - “ “
427	PID Low Pass Filter Time	.01 thru .1 sec. – “ “

DANFOSS VLT 6000 HVAC PARAMETERS FOR ECOGATE CONTROL

QUICK MENU PARAMETERS

001	Language	English
102	Motor Power	Motor Plate
103	Motor Voltage	“
104	Motor Frequency	“
105	Motor Current	“
106	Motor Nom. Speed	“
201	Frequency Lower Limit	0
202	Frequency Upper Limit	60
206	Ramp Up Time	“ “
207	Ramp Down Time	“ “
323	Relay 1 Function	Alarm
326	Relay 2 Function	Run

EXTENDED MENU PARAMETERS

007	Large Readout	Power [kW]
008	Small Readout 1	Analog input 53 [V]
009	Small Readout 2	Feedback [units]
010	Small Readout 3	Frequency [Hz]
100	Configuration	CLOSED LOOP
204	Min. Reference	0
205	Max. Reference	10
308	Ai [V] 53 funct.	Feedback
315	Ai 53 scale low	0
316	Ai 53 scale high	10
402	Flying Start	Enable
413	Min. Feedback	0
414	Max. Feedback	100
415	Ref./Fdbk unit	%
423	PID Proportional Gain	.1 thru 1 – depends on pars. 201, 202 315 and 316
424	PID Integration Time	9,999.00
427	PID Low Pass Filter Time	0.01

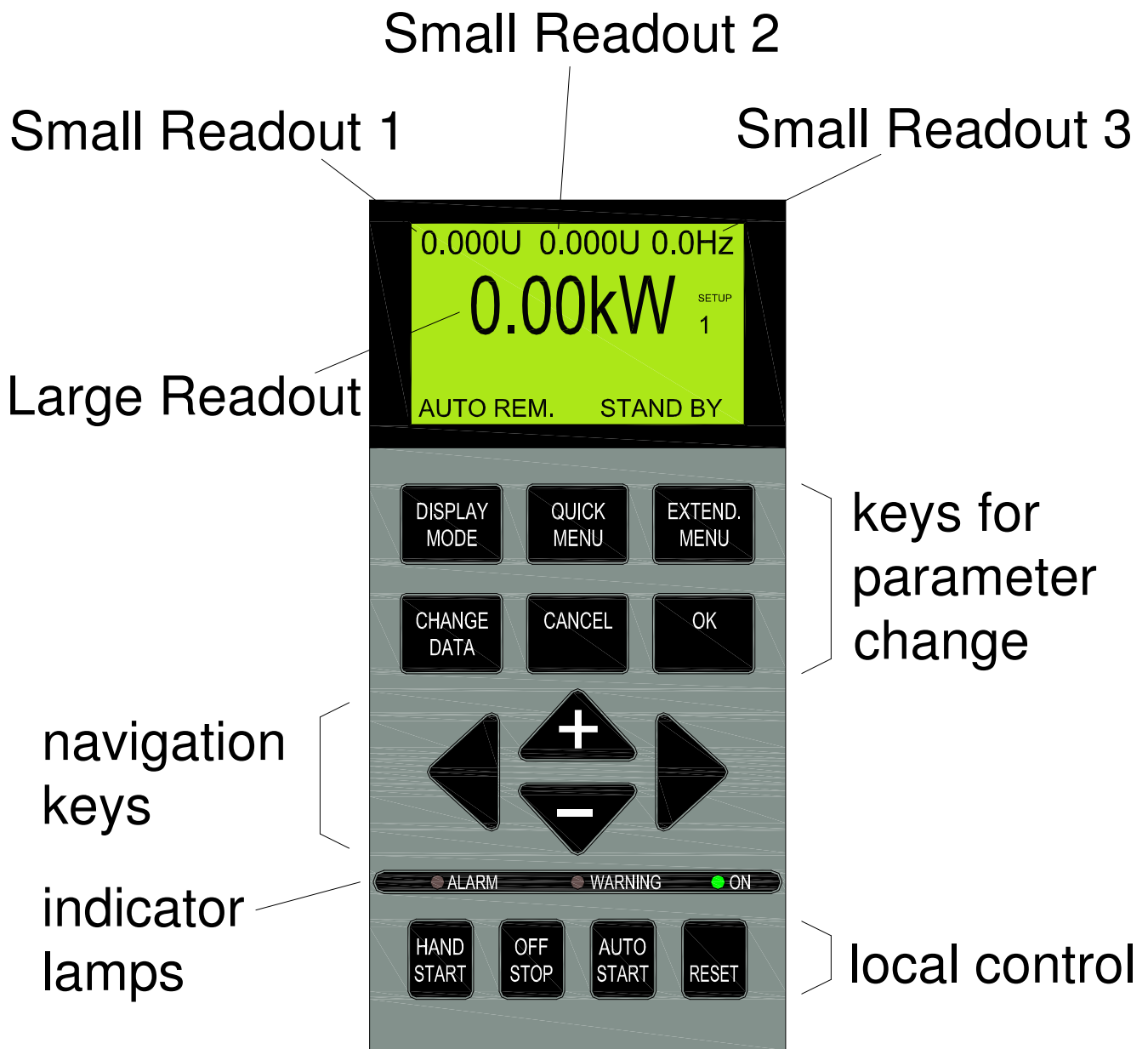

LOCAL CONTROL PANEL (LCP)

Figure 1

DO NOT SCALE IF IN DOUBT ASK

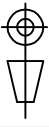

Revisions				
Zone	Rev	Description	Date	Approved

DWYER PRESSURE TRANSDUCER
674-444
(optional)

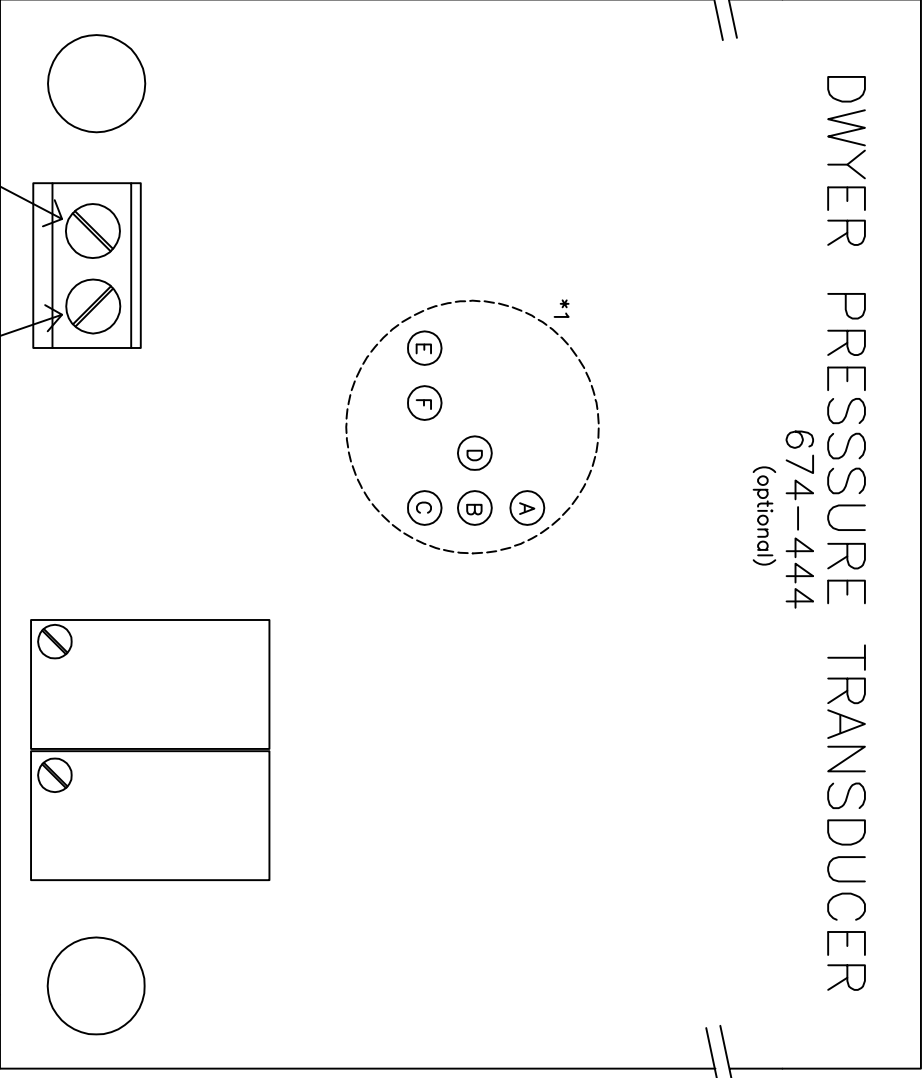
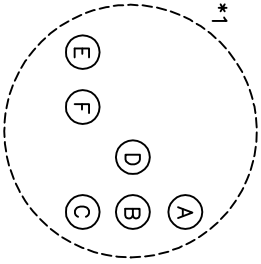

*1)
Jumper D to B for
0 to 15" scaling.

Note:

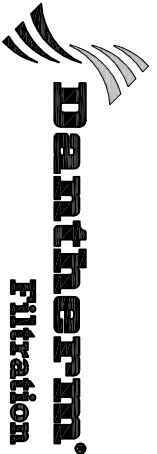

102 Transit Ave.
Thomasville, NC 27360
Tel.: (336) 821-0800
Fax: (336) 821-0890

Date	Name	Part Number	Title	Scale	Drawing Number	Rev	Sht
03/13/06	TFD	FILE: DWYER HOOK UP.DWG	DWYER PRESSURE TRANSDUCER TO DANFOSS VLT 6000 HVAC DRIVE HOOK UP	N/A	VFDSCH003		
Checked				Size A			

This drawing is confidential and is the exclusive property of Danttherm Filtration, Inc.. No unauthorized use, copy or disclosure is to be made and it is returned whenever required.

DO NOT SCALE IF IN DOUBT ASK



Revisions				
Zone	Rev	Description	Date	Approved

VLT 6000 DRIVE

CS AND NFK CONTROL PANELS

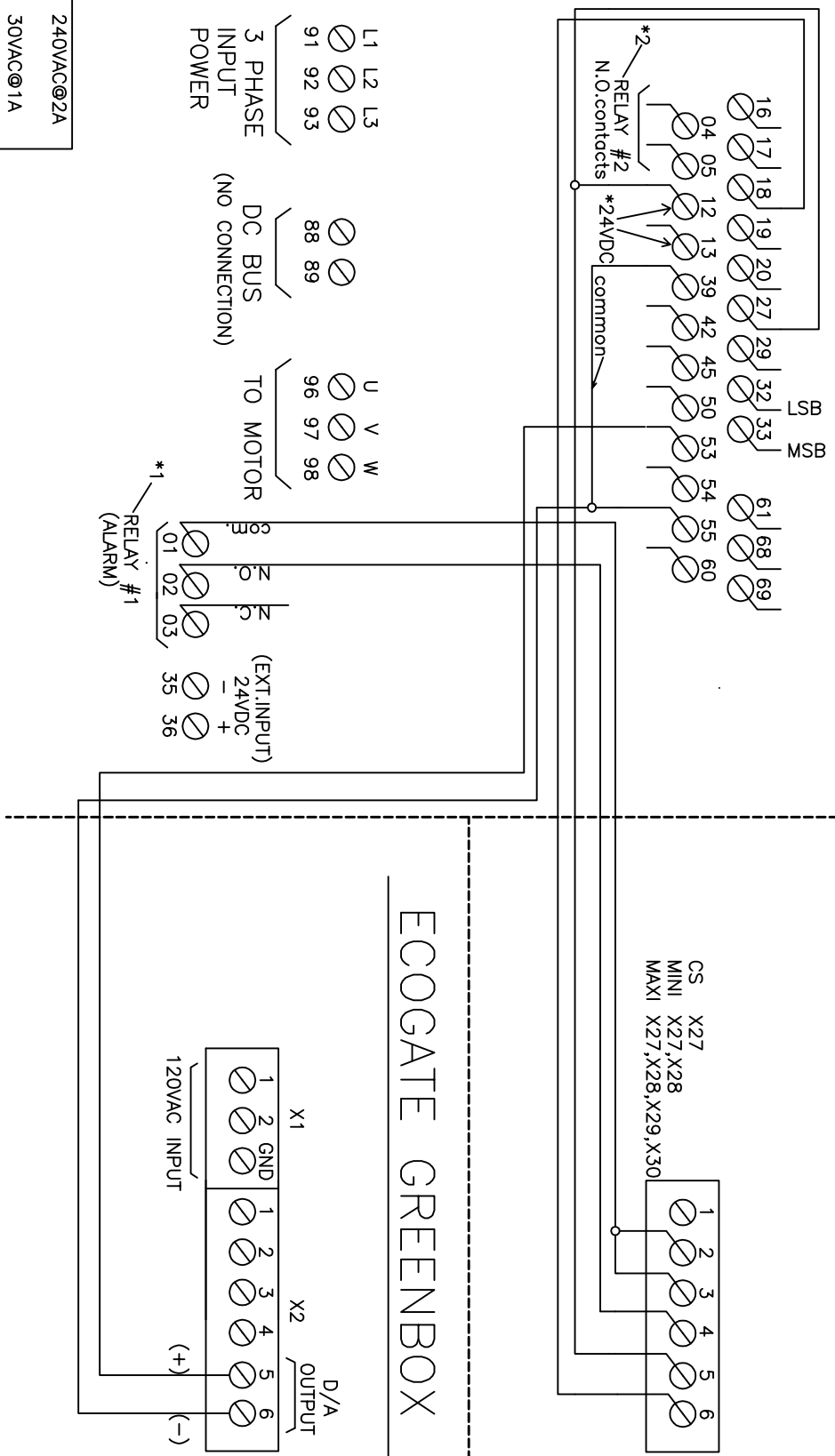

102 Transit Ave.
 Thomasville, NC 27360
 Tel.: (336) 821-0800
 Fax: (336) 821-0890

Drawn	Date	Name
Checked	02/22/06	TFD

Part Number
 FILE: V16000 to ecogate
 greenbox pro plus.dwg

Title	Scale	Drawing Number	Rev	Sht
DRIVE, CONTROL PANEL AND GREENBOX HOOK UP	N/A	VFDSCH004		

This drawing is confidential and is the exclusive property of Danttherm Filtration, Inc.. No unauthorized use, copy or disclosure is to be made and it is returned whenever required.

notes:
 *1 contacts, 240VAC@2A
 *2 contacts, 30VAC@1A

DO NOT SCALE IF IN DOUBT ASK

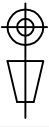

Revisions			Date	Approved
Zone	Rev	Description	Date	Approved

VLT 6000 DRIVE

CS AND NFK CONTROL PANELS

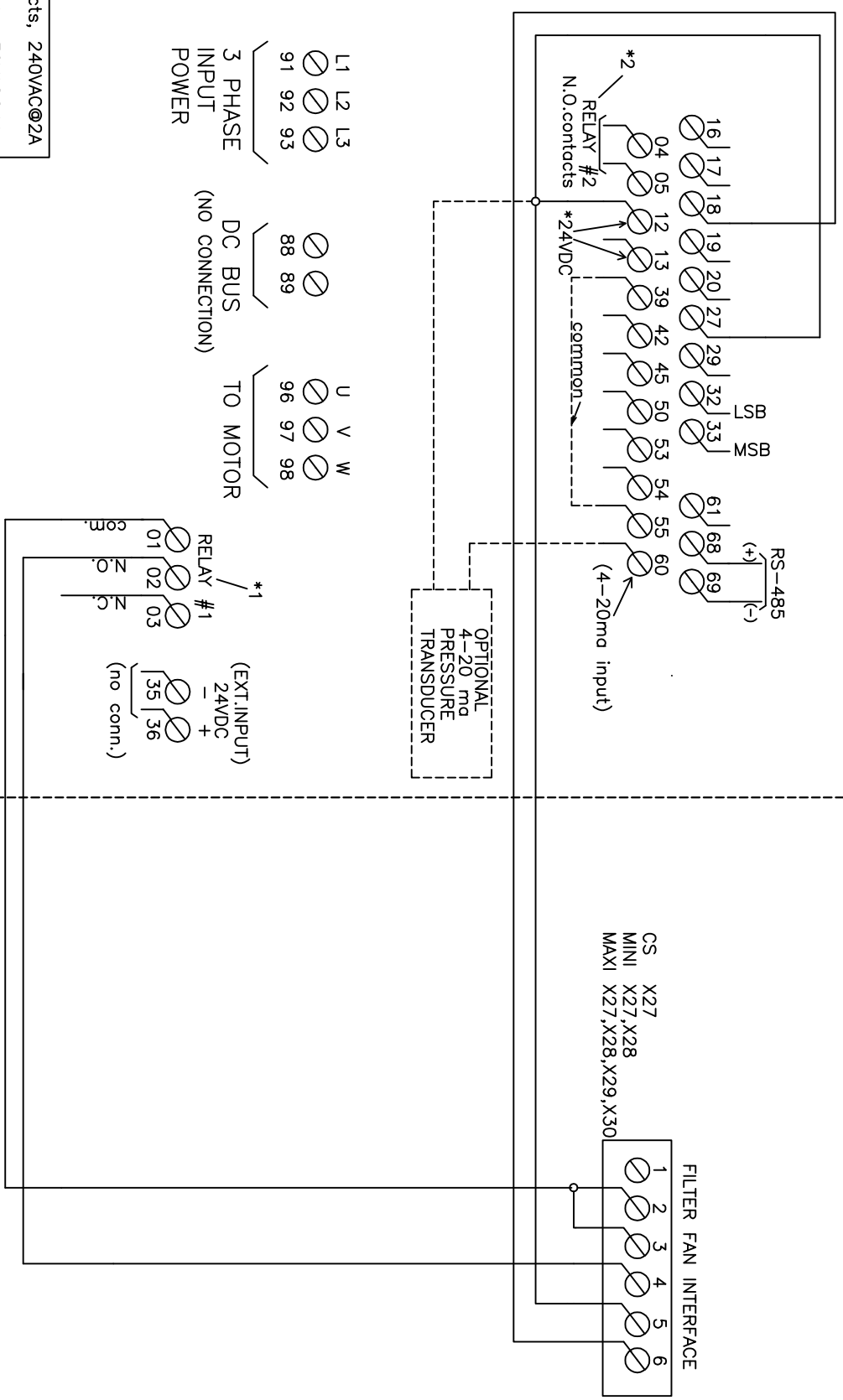

notes:
 *1 contacts, 240VAC@2A
 *2 contacts, 30VAC@1A

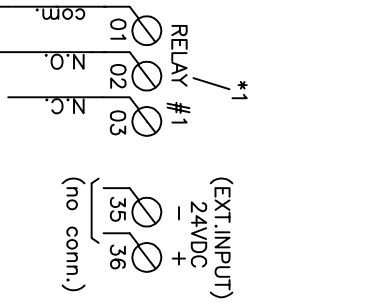
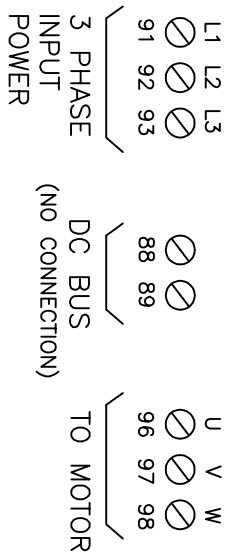

Danfoss
 Filtration

102 Transit Ave.
 Thomasville, NC 27360
 Tel.: (336) 821-0800
 Fax: (336) 821-0890

Drawn	01/16/06	TFD	Part Number	FILE: DANFOSS HOOK UP 2.DWG	Title	DANFOSS TO CONTROL PANEL HOOK UP
Checked			Name		Scale	N/A
			Date		Size	A
					Drawing Number	VFDSCH002
					Rev	
					Sht	

This drawing is confidential and is the exclusive property of Dantherm Filtration, Inc.. No unauthorized use/copy or disclosure is to be made and it is returned whenever required.

DO NOT SCALE IF IN DOUBT ASK

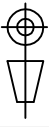

Revisions			
Zone	Rev	Description	Date

VLT 6000 DRIVE

NF-8HD CONTROL PANEL

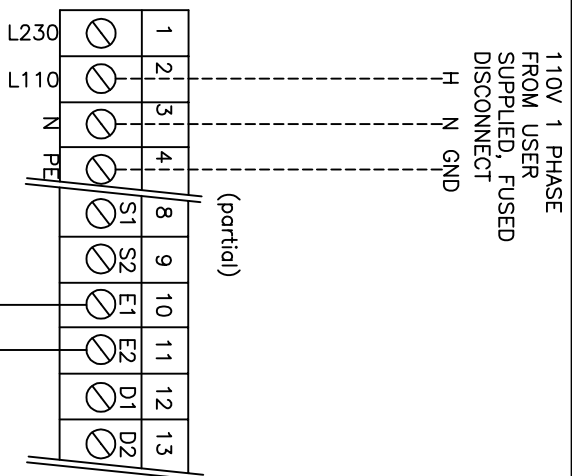
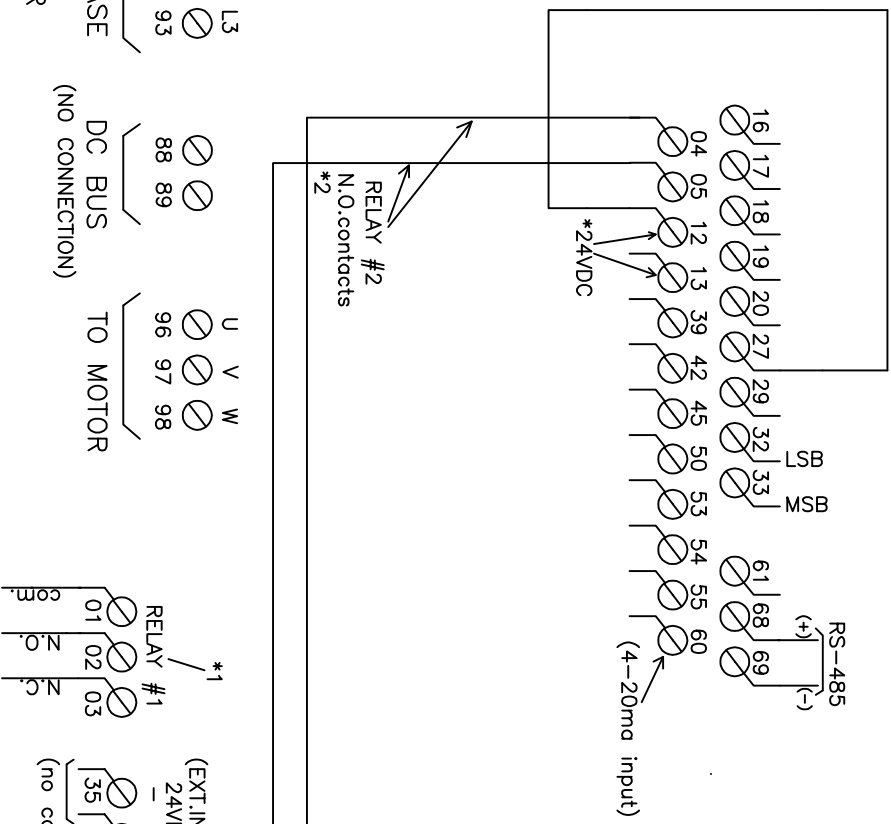

notes:
 *1 contacts, 240VAC@2A
 *2 contacts, 30VAC@1A
 42.5VDC@1A

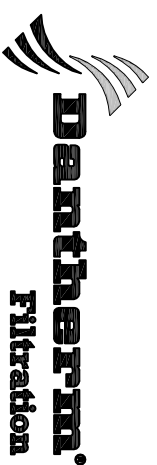

102 Transit Ave.
 Thomasville, NC 27360
 Tel.: (336) 821-0800
 Fax: (336) 821-0890

Date	Name	Part Number	Title	Scale	Drawing Number	Rev	Sht
06/19/06	TFD	DANFOSS TO NF8.DWG	DANFOSS TO NF-8HD CONTROL PANEL HOOK UP	N/A	VFDSCH005		

This drawing is confidential and is the exclusive property of Danttherm Filtration, Inc.. No unauthorized use, copy or disclosure is to be made and it is returned whenever required.