



OPERATING & MAINTENANCE MANUAL FOR CYCLONE FILTER

(01JULY04 Rev. 1.0)

**DANTHERM FILTRATION
102 Transit Ave.
PO Box 429
Thomasville, NC 27361-0429
Telephone: (800) 533-5286
Fax: (336) 821-0890**

Warning: No portion of this manual may be reproduced in any shape or form without the written approval of DANTHERM Systems Inc. Revised July 27, 2004

TABLE OF CONTENTS

| | |
|---|--------------|
| Warning..... | 3 |
| Introduction | 4 |
| How the Cyclone Filter works | 5 |
| Section 1.0 Pre-Installation..... | 6-7 |
| Section 2.0 Safety Instructions | 8-9 |
| Section 3.0 Erecting/Assembly Instructions... | 10-13 |
| Section 4.0 System Operation..... | 14-15 |
| Section 5.0 System Maintenance | 16-17 |
| Section 6.0 CSP Plenum Filter | 18-19 |
| Section 7.0 Spare Parts..... | 20 |
| Section 8.0 Electrical Schematics..... | 20 |
| Section 9.0 Material-handling Fan/Airlock | 21-42 |
| Section 10.0 Warranty | 43 |

WARNING

Before performing any service or maintenance work on this equipment, the safety procedure listed below must be followed.

1. Disconnect all power supplies. NOTE: Equipment may have more than one power supply to disconnect.
2. Lock off all disconnected power supplies to prevent unauthorized personnel from turning on equipment while work is being performed.
3. Personnel accessing a dust compartment must wear proper breathing equipment and eye protection.
4. When working overhead in a storage silo, be sure proper supports are in place to prevent collapse of material above or below the working area.
5. When working overhead or in a storage silo, personnel must wear safety belts with properly attached lifelines.
6. When service/maintenance is completed, install all guards and inspection doors before starting up equipment again.

INTRODUCTION

The following operating and maintenance instructions are designed to help you get maximum economy from your DANTHERM system with minimum downtime.

To ensure the proper operation and routine maintenance of the system that are critical to minimizing downtime, avoiding costly repairs, and maximizing system performance, we recommend that you make a trusted employee responsible for operating and maintaining your DANTHERM system. To further reduce downtime, we recommend that you stock parts that routinely wear.

Service maintenance and spare parts may be ordered from:

**DANTHERM FILTRATION
102 Transit Ave.
P.O. Box 429
Thomasville, NC 27361-0429
Telephone: (800) 533-5286
Fax: (336) 821-0890**

DANTHERM is continually improving its technical manual to accommodate every end user. However, if there is a topic not covered in the manual please call our customer service department at the above number.

“WHEN IN DOUBT PLEASE ASK”

How the Cyclone filter works

...A Positive Pressure Configuration

1. During normal operation, the dust travels down the supply duct, into the material handling fan **4**. From there, it is blown up into the cyclone.
2. Upon entering the cyclone, the air and material are diverted into a spiral motion around the inside perimeter **2**. The centrifugal force applied by the side wall allows the heavier material to fall out of the air stream and into the collection bin **6** (or through a rotary air lock) **6**.
3. The air and some of the finer dust **5** is then exhausted out of the cyclone via an inner cone **3**. An outlet "volute" **3** is a weather cowl that also acts as a transition for those applications which require a secondary filter **7**.
4. The air and some fine dust exits the "volute" where it may be exhausted to atmosphere **5** or into a secondary filter.

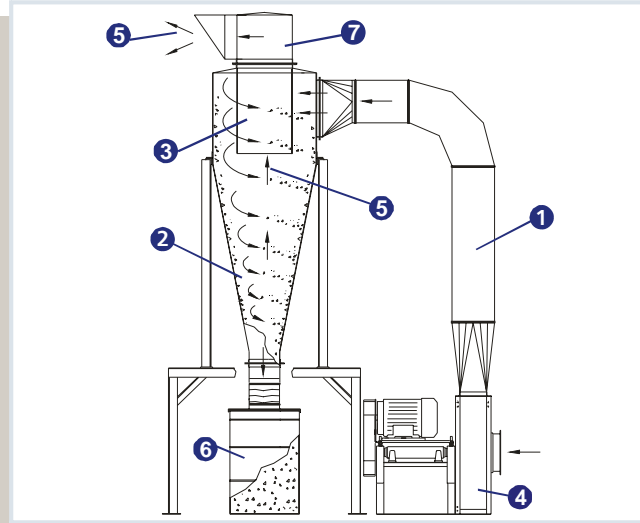

...A Negative Pressure Configuration

1. During normal operation, the dust is drawn down the supply duct **1** and into the cyclone.
2. Upon entering the cyclone, the air and material are diverted into a spiral motion around the inside perimeter **2**. The centrifugal force applied by the side wall allows the heavier material to fall out of the air stream and into the collection bin **6**. (Or through a rotary air lock).
3. The air and some of the finer dust **5** is then exhausted out of the cyclone via an inner cone **3**.
4. The air and some fine dust then passes through the main fan **4** where it may be exhausted to atmosphere **5** or into a secondary filter.

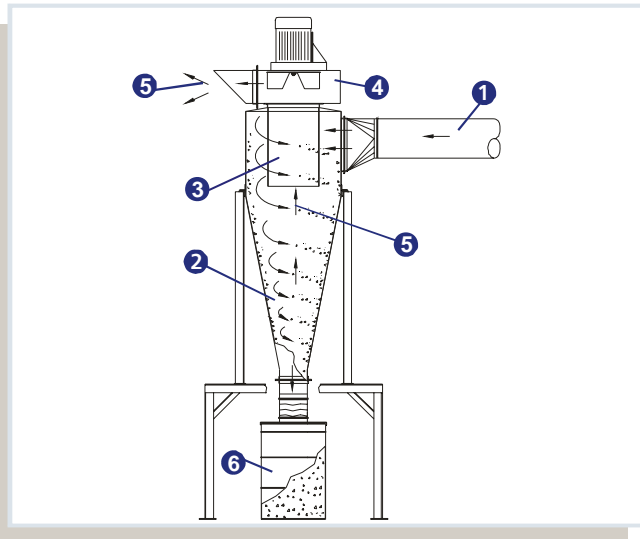

NOTE: Please consult with your Dantherm Filtration representative for compressed air requirements

Section 1.0: Pre-Installation

1.1: Before your unit arrives

Electrical

Please make sure the voltage specified on the order acknowledgement is consistent with the building voltage prior to shipping. It is the customer's responsibility to ensure adequate electrical capacity based upon loads which can be provided by DANTHERM.

If the motor starter has been purchased from DANTHERM, it will be pre-wired to the specified voltage. DANTHERM does NOT supply any disconnects, fused or un-fused.

It is the customer's responsibility to coordinate ALL field wiring with a LICENSED electrician. Motor and motor starter warranties are VOID unless wired by a LICENSED electrician.

Foundations

Units MUST be set on a level surface

It is the customer's responsibility to adhere to local building codes that relate to foundation guidelines. DANTHERM does NOT provide any recommendations that relate to type of foundation, thickness or construction details.

DANTHERM will supply drawings that detail footprint, weight and anchoring methods.

Permits

ALL permits (building, air or otherwise) are the responsibility of the end user.

1.2: Inspection upon arrival

Immediately upon receipt of the equipment, carefully inspect all parts to make certain that the unit is in good condition and that all items listed on the packing list are received. Even though the equipment is properly secured on skids at our plant it is possible for it to be damaged in transit. Please pay particular attention to the large components such as: the filter, fan housing and pipe fittings (if included) for obvious damage.

Note all damage and shortage on the Bill of Lading and take immediate steps to file reports or damage claims directly with the carrier. All damages incurred to the unit in transit are the responsibility of the common carrier or freight company. DANTHERM makes shipment F.O.B. from its factory, that is ownership passes to purchaser when the equipment is **loaded and accepted** by the trucker.

ANY CLAIMS FOR "IN TRANSIT" DAMAGE OR SHORTAGES MUST BE BROUGHT AGAINST THE CARRIER BY THE PURCHASER.

1.3: Offloading

The Cyclone dust collection unit will be shipped in four pieces (structure not shown) see figure one below. Smaller Cyclone dust collection units may be offloaded with a LARGE forklift. We HIGHLY recommend the use of a crane for offloading larger Cyclone units. It is further recommended that the Cyclone (once fully assembled) be set directly to the pad or piers upon which it will be installed.



Figure 1 - Cyclone will ship unassembled in this fashion

1.4: Required equipment

- Crane/Fork Lift Truck
- Lifting straps, shackles and pins
- Screwdriver
- Socket wrenches, metric sizes (or compressed air impact gun)
- Vice grips
- Hammer
- Nibbler or tin snips

1.5: Storage procedures

If the unit cannot be installed immediately, the collector components should be stored as follows:

- Motor Starter and Control Panels: Store in-doors in a temperature and humidity controlled environment.
- Cyclone, and Fan Assemblies: Place off the ground with all external cavities covered to prevent collection of water.
- Pipe Return Components shipped in boxes: Store indoors, if possible.
- Large Pipe Fitting and Return Air Components: Store upright; take care to not stack materials on them that could damage their shape; cover these parts to prevent collection of water.

Section 2.0: Safety Regulations NF-10 & Instructions

“DISREGARDING DANTHERM SAFETY REGULATIONS ENTAILS A HEAVY SAFETY RISK”

2.1: Maintenance

Maintenance must be performed to DANTHERM maintenance directions.

Open fire, sparking or other form of heat generation such as: Welding, grinding, boring/drilling or smoking etc. may not take place closer than 10 feet to filters, fans, pipe components, waste containers, etc. working with explosive atmosphere, such as dust laden air.

It must be ensured that cleaning be performed on and around the system components to prevent inflammable and explosive dust waste from igniting and causing heavy damage.

To prevent static electricity generation in systems with an inflammable and explosive atmosphere, it must be ensured that such systems with connected ducts etc. is duly grounded.

Maintenance work may not commence until the total system has stopped properly, and locking the main switch cuts off the power supply in a safe manner, for instance.

Inspection inside the system by opening inspection doors and similar may not be performed until after the usual cleaning periods have been run, until filters are free of dust accumulation, and dust/waste has been carried to silo/waste bin.

In this connection, it must be checked whether the filter regeneration has been adequate, by examining the residual dust accumulation on the sleeves.

Inspection by opening the inspection doors and similar may be performed only when personal safety equipment is adapted to the particular conditions.

If a movable ladder is used for the work, the ladder must be secured properly for stability before commencing the work.

2.2: Service and Repair

Specially trained staff may only perform service and repair.

Before any work can begin, the main switch must cut the energy supply, and it must be ensured that no unintended restart may occur, for instance by locking the main switch. Accumulated energy, such as in a compressed air system, must also be interrupted, possibly discharged altogether, before commencing the work.

For service and repair work making it necessary to stay in dust laden air, for instance in the filter, as a minimum the following safety equipment must be used. For toxic dust, supplemented by own special equipment, the following must be used:

- A. **Respiratory Protective Device, possibly with fresh air supplies**
- B. **Goggles possibly shield mask in connection with fresh air supply**

For fire/explosive dust, the following must also be used:

- C. **Fire Retardant Suit**
- D. **Fire Retardant Working Gloves**
- E. **Safety Footwear**
- F. **Safety Helmet**
- G. **Sparkless tools wherever possible**

Inspection of filters from the clean air side/in the clean air chamber may be performed only when the filter system has stopped. For this, also the personal safety equipment referred to above must be used.

If cleaning is performed using a vacuum cleaner, protection must be provided against static electric charging in the suction arrangement.

Boring of holes in filter housing or adjoining pipe ducts may be performed only when the system has stopped and been cleaned, while taking great care and without any heat generation.

If any faults occur in the electric system which make the system stop and restart has been cut, the faulty component may not be removed to allow for further operation. Proper troubleshooting and repair prior to restarting must be performed.

Disposal of replaced components, dust/waste from cleaning, as well as other waste, must be performed to the guidelines for the particular materials. The local authorities will usually have laid down these guidelines. In case of doubt, the person responsible for company safety should be consulted.

Section 3.0: Erecting & Assembly instructions for Cyclone filter and accessories

3.1: Introduction

Erecting and start-up of the Cyclone filter is only to be performed by educated and experienced staff, as possible errors may cause damages and/or reduce the lifetime of the filter considerably. These instructions and the safety regulation NF-10 should be read carefully prior to erecting and start-up (see pages 8 & 9)

3.2: The main filter components (See Figure 1 below)

1. Cyclone top
2. Cyclone cone
3. Filter structure
4. Material handling fan
5. Filter inlet
6. Filter outlet
7. Single or double barrel discharge (rotary airlock, if provided)
8. Electrical control panel (Not shown)

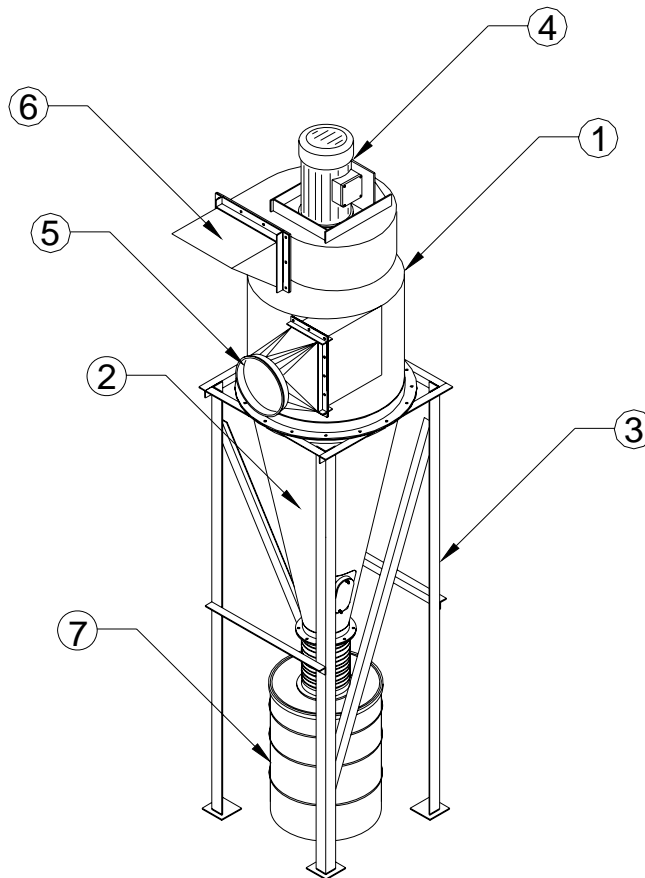

CYCLONE UNIT - FIGURE 1

3.3: Cyclone Assembly

NOTE: All necessary parts, manual, tube of caulk, nuts and bolts, and fan motor starter are shipped in a spare box with the cyclone.

Step 1

Remove the structure from the skid using a forklift or crane and place it on a level concrete foundation. It is highly recommended that the structure is bolted to the concrete foundation.

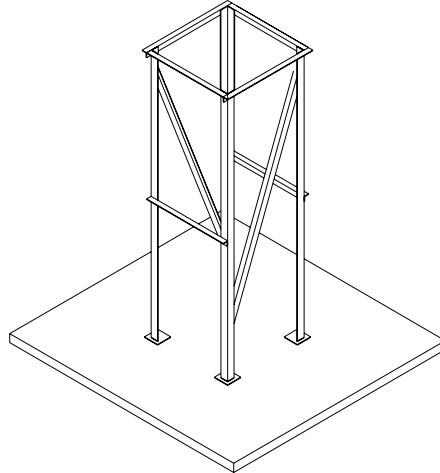
**Step 2**

The cyclone cone should be lifted with a crane (for larger units) whenever possible. The cone should be placed onto the structure as shown below and should be caulked (tube of caulk supplied) around the perimeter of the angle flange.

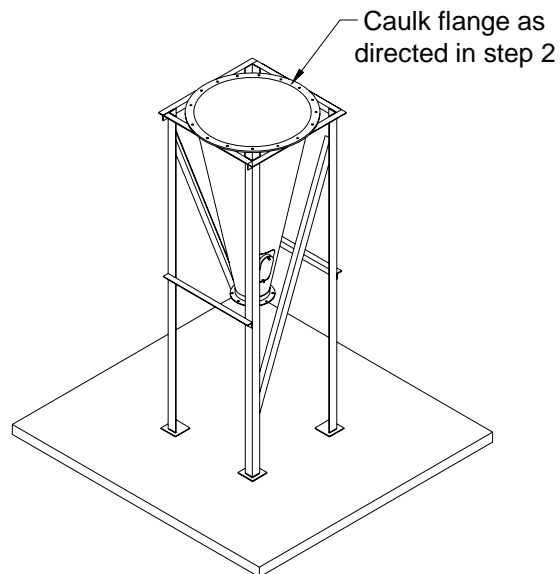

Step 3

Attach the cyclone top with fan to the cyclone cone. Using the supplied hardware bolt the two angle flanges together. Once the two pieces have been fitted together it is suggested that you weld the angle flange to the structure or drill holes through the angle flange into the structure and bolt them into place at those points. It also suggested that the any transitions that need to be attached to the inlet and/or outlet be done prior to setting the top into place, be sure to caulk between the flanges for an airtight seal, prior to bolting them into place.

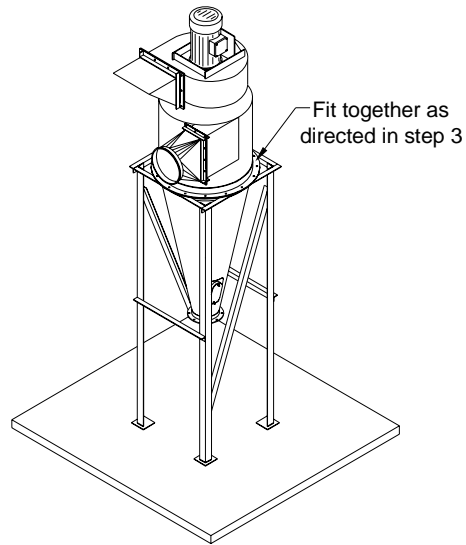
**Step 4**

Attach the barrel(s) (or rotary airlock, if provided) to the bottom of the cyclone discharge opening. Be sure to caulk between the two flanges for an airtight seal prior to bolting the flanged hose adapter in place.

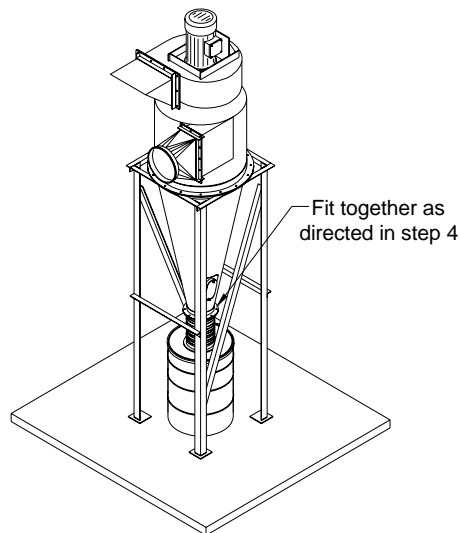

3.4: Placing of the filter

The filter is placed according to the installation drawing considering that service should be possible, including opening of inspection doors, dismounting of screens and similar, electrical connection can be performed etc. also consider that a possible pressure wave from the explosion relief door could be released. In case of doubt please, consult the technical department of DANTHERM.

3.5: Mounting

WARNING - WARNING - WARNING - WARNING – WARNING

When the mounting has been completed it should be checked that all filter elements have been mounted correctly and that the filter has been sealed so that no dust will leak out.

Inspection doors and similar in filters or adjoining components may only be established when opening alone can be performed by application of tools. On or immediately beside the door, relevant warning signs should be set up. The warning sign “Rotating parts” must always be mounted. Catches, handles etc. are not allowed!

External emergency stops must be placed within 150 feet from the filter, connected machines, or similar.

3.6: Electrical connection of electrical control, indicators, fans etc.

Cyclone filters are supplied with an electrical control panel that is to be mounted by skilled electricians in accordance with local code.

For filters with no factory mounted electrical control an electrical control that is made according to the regulations of DANTHERM must be connected. If this is not complied with, there will be no guarantee on the product.

Electrical connection of ventilator motor, watches, etc. must be performed according to the rules in force for the components in question.

The electrical cable connections must be performed so that the cables cannot be stretched and so that no water will penetrate the cable entry along the cables.

3.7: Invisible operation

If the filter is part of a plant where the function/non-function of the filter is not directly noticeable, and where a defective filter function may lead to a dangerous situation, the operation of the filter must be watched e.g. by means of a pressure switch so that malfunction can be alarmed immediately.

Section 4.0: System Operation the Cyclone and Fan

Please read the SAFETY INSTRUCTIONS NF10 carefully before commencing any type of activity. If the safety instructions are not followed, this may lead to serious personal injury. Access doors may only be opened in accordance with the safety instructions. Before attempting to start the plant in any way, all guards, doors etc. must be closed, restored and locked.

Authorized employees may only perform adjustment of the electrical controls without cover when the electrical control is not connected to the supply voltage and in accordance with the current safety rules.

Your Cyclone filter and fan is produced by:

DANTHERM FILTRATION
102 Transit Avenue
P. O. Box 429
Thomasville, N.C. 27361-0429
Telephone: (800) 533-5286
Fax: (336) 821-0890

The users of this filter will normally be working in areas, which are connected to the filter by means of a pipe system. Therefore, there is no permanent place for the operator for the users of the filter. Start/stop is activated by means of an electrical control (normally in connection with start of a fan connected to the filter). Start/stop will often be located near the operator's normal workplace, i.e. physically separated from the filter.

4.1: The Main Components of the Filter (See Figure 1, page 10).

1. Cyclone top
2. Cyclone cone
3. Filter structure
4. Material handling fan
5. Filter inlet
6. Filter outlet
7. Single or double barrel discharge (rotary airlock, if provided)
8. Electrical control panel (Not shown)

4.2: Operation

The Initial Start

The initial start must take place in accordance with the maintenance and mounting instructions for Cyclone filters and must be performed by authorized employees.

Normal Start

Pressing the start button on the motor starter that is connected to the filter fan makes a normal start. If an external start/stop function has been established, the filter can also be started by means of this.

Normal Stop

A normal stop is made by pressing the stop button on the electrical motor starter or on the external start/stop if such has been established.

Emptying

The filters must be inspected in accordance with the maintenance instructions.

The material that is collected by the cyclone will either be discharged into a single barrel, double barrel, or a rotary airlock. Proper care should be taken to insure that the barrels, bin, or dumpster, do not back up or the internal parts of the fan or cyclone can be damaged. The correct safety equipment and safety instructions must be used/followed.

Dust must not be stored for long periods of time in the waste containers of the filter. These containers must be emptied after each operation period. The best time for emptying the containers if there are large amounts of fine dust is just before the filter is started; at this point in time, the inhalable dust has had maximum time to deposit.

NOTE: The barrels must be emptied as each becomes full. You cannot wait until all barrels are full to empty the unit.

Section 5.0: System Maintenance for Cyclone Filter and Fan

Please read the "SAFETY INSTRUCTIONS NF10" carefully before commencing any type of activity. If the safety instructions are not followed, this may lead to serious personal injury.

Authorized employees may only perform adjustment of the electrical controls without cover when the electrical control is not connected to the supply voltage and in accordance with the current safety rules.

Please note the following, among other things:

Before any type of inspection or maintenance activities are commenced, the filter must be completely stopped, the compressed-air tanks etc. must be free from pressure and the electrical control must be disconnected in such a way that the filter cannot be started inadvertently. The filter may not be started again until all guards, doors etc. have been restored correctly.

Only use original DANTHERM spare parts for repairs.

5.1: Maintenance

Cyclone

The cyclone housing is made from galvanized steel plate. Inspect the body and structure periodically for wear, holes, or possible rust from wear and tear.

Fan

The fan wheel of the fan has been carefully balanced at the factory in order to ensure a vibration-free function. If any vibrations arise during the operation, dust deposits on the fan wheel will normally cause them. These vibrations will stop once the fan wheel has been cleaned. If the vibrations do not stop after cleaning of the fan wheel, a service technician must be contacted, as vibrations may reduce the life of the fan. See Section 9 for factory-supplied information on operation and maintenance.

Motor (Optional)

Normally, the motor maintenance will comprise cleaning of the motor and lubrication of bearings. See Section 9 for factory-supplied information on operation and maintenance.

Rotary Airlock (If provided)

If a rotary airlock is utilized inspect the bottom flange of the material discharge for vibration or wear. The rubber veins on the airlock should be inspected periodically for wear and tear. See Section 9 for factory-supplied information on operation and maintenance.

5.2: Maintenance schedule

The installation should be continuously checked according to the schedule below. The time intervals indicated apply to single shift operation (8 hours daily) and should be decreased proportionally on day and night shift operation.

| <u>CHECK</u> | <u>INTERVAL (Months)</u> |
|--|---------------------------------|
| Filter Bags - Attachment, wear & tear | 3 |
| Cyclone body, pipe fittings - wear & tear, leaking, etc. | 6 |
| Hopper - wear & tear, dust build-up | 3 |
| Fan Bearings - Lubrication | 3 |
| Fan wheel - wear & tear, balance | 24 |
| Gear boxes – oil level | 6 |
| Gear boxes – oil replacement | 12 |

5.3: Lubrication

Electric motors are lubricated according to the manufacturer's instructions. The flange bearings of the filter are lubricated by the manufacturer when supplied, and should be lubricated according to the maintenance schedule and checked for wear and tear.

Section 6.0: CSP Plenum Filter

6.1: Operation

Plenum after-filters provide an inexpensive solution to cleaning the exhausted air from the cyclone. The after-filter can be easily adapted to the DANTHERM cyclone. The filter media is a woven polyester media "Beane" and is not designed for very large amounts of fine dust. i.e. from large wood sanders that produce large amounts of dust.

Installation requires minimal skills and tools due to the utilization of the "QF" clamping system, which connects all the plenum modules together. Please see the example below of a standard type of plenum filter.



Cyclone with CSP20-4 plenum after-filter

6.2: Plenum Filter Bags

The durability of the filter bags vary within wide limits depending on the operational conditions, the filter stress, the type of dust, and the dust load. Under normal conditions, the durability is from 5 to 7 years.

******The filter bags must be checked frequently for proper bag attachment.

During normal operation, a certain dust layer should remain on the inside of the bags, even after cleaning, - as this layer will increase the high degree of separation. A certain amount of fine dust will be deposited in the filter fabric and cannot be blown off through regeneration. This means that the filter bag will lose its efficiency over a long period, due to deposit in the fabric, and due to wear and tear.

In case the concentration of fine dust in the air is extremely high, the filter bags can be cleaned mechanically through "beating", "shaking", or the like.

6.3: Maintenance Schedule of Plenum Assembly

Every 25 Hours of Operation (Approx. every 6 Months if filter is in operation 8 hours a day) :

1. Check Clamps on Filter Bag Adapters for tightness.
2. Inspect Filter Bags for tears or holes.
3. Inspect Waste Barrels or Bags for tears or holes.

Lubrication

Electric motors are lubricated according to the manufacturer's instructions. The flange bearings of the filter are lubricated by the manufacturer when supplied, and should be lubricated according to the maintenance schedule and checked for wear and tear.

The oil/grease level in the gear box should be checked according to the check list. On topping up, use grades as recommended by the manufacturer.

6.4: Cleaning Method for Plenum Bags

1. Simply shut down the Material Handling Fan by pushing the **STOP** button located on the electrical motor starter.
2. Allow 120 seconds of time delay for the Material Handling Fan to completely come to a rest before starting the Cleaning Process. The time delay is crucial in order for the proper cleaning of the filter media.
3. Repeatedly Strike filter bag with a rigid rod at midpoint of Plenum Bag. Strike bag on two sides at least 10 times on each side. Continue the process until all bags have been shaken down.
4. Allow 120 second to elapse before starting the Material Handling Fan. This time delay is to allow the material to settle in the bags or barrels and not be reintrained into the filter bags when the system is started up.

Note: The CSP Plenum Filter System should go through a Cleaning Cycle after every four hours of operation.

Section 7.0: Recommended spare parts

7.1: Spare parts lists

Filter Bags

CSP Plenum bags - Part # xxxxxxxx – (recommended safety stock 1 set)

V-Belt drives for material handling fan (if supplied) – (recommended safety stock 2)

7.2: Recommended lubricants

Gear Boxes: **Exxon # FIPRAX Code EP370** or **Shell equivalent – Shell grease #S3655**

Bearings: **SHELL Dolium R**

Section 8.0: Electrical Schematics

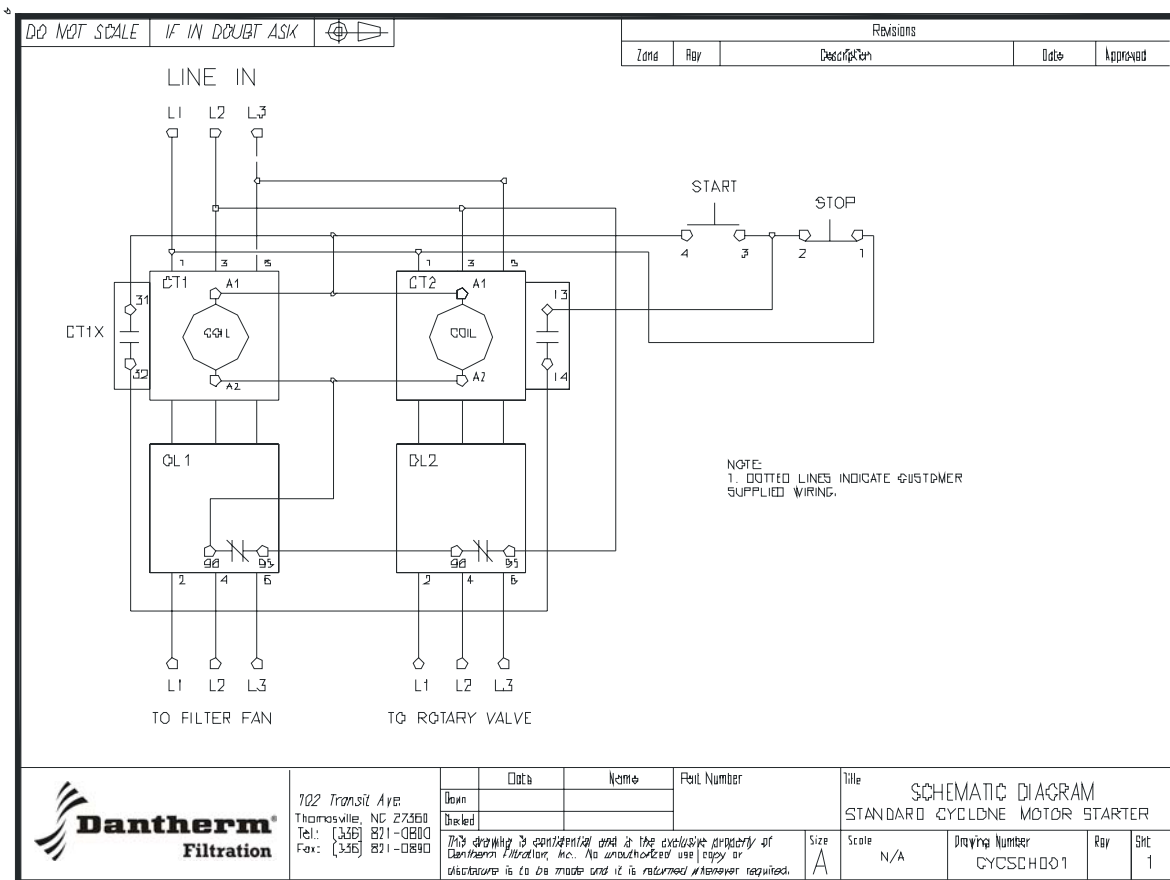

Section 9.0: Cincinnati Fan and Motor

9.1: Fan & Motor

OPERATING & MAINTENANCE INSTRUCTIONS AND PARTS LIST

for
HDBI - Backward Inclined Blowers
HDAF - Airfoil Wheel Blowers
RBE - Radial Blade Exhausters
HP - High Pressure Blowers

CONTENTS

- I. General Safety NotesPage 2
- II. ReceivingPage 2
- III. Handling.....Page 2
- IV. General Installation Instructions.....Page 2
- V. Operation.....Page 3
- VI. General MaintenancePage 3
- VII. V-belt Drives.....Pages 3, 4 & 5
- VIII. Bearing Maintenance.....Pages 4 & 5
- IX. Warranty.....Page 5
- X. Ordering Replacement PartsPage 5
- XI. Trouble ShootingPage 6
- XII. Assembly DrawingsPages 7-12

NOTICE
If fan will not be put into operation within 30 days, obtain long-term storage instructions from our website (www.cincinnati-fan.com) or your local Cincinnati Fan Sales Office.

⚠ DANGER

ALL FANS AND BLOWERS SHOWN HAVE ROTATING PARTS AND PINCH POINTS. SEVERE PERSONAL INJURY CAN RESULT IF OPERATED WITHOUT GUARDS. STAY AWAY FROM ROTATING EQUIPMENT UNLESS IT IS DISCONNECTED FROM ITS POWER SOURCE AND ALL ROTATING PARTS HAVE STOPPED MOVING.
READ ALL OPERATING INSTRUCTIONS CONTAINED HEREIN BEFORE INSTALLING EQUIPMENT.

⚠ DANGER

NO GUARANTEE OF ANY LEVEL OF SPARK RESISTANCE IS IMPLIED BY SPARK RESISTANT CONSTRUCTION. IT HAS BEEN DEMONSTRATED THAT ALUMINUM IMPELLERS RUBBING ON RUSTY STEEL MAY CAUSE HIGH INTENSITY SPARKS. AIR STREAM MATERIAL AND DEBRIS OR OTHER SYSTEM FACTORS MAY ALSO CAUSE SPARKS.



PART # 01001
CATALOG #PMK-1001
SUPERSEDES: PMK-1293

7697 Snider Road, Mason, Ohio 45040-9135 (513) 573-0600

I. GENERAL SAFETY NOTES

1. Rotating parts including shaft and V-belt drives must be properly guarded to prevent personal injury.
2. Electrical wiring must be accomplished by a qualified electrician in accordance with all applicable codes.
3. Care should be taken:
 - Not to run fan above its safe speed (See Performance Tables in Sales Catalog or call CF sales office).
 - Not to operate in excessive temperatures (See limitations in Sales Catalog or call CF sales office).
 - Not to operate in dangerous environments.
 - Read all instructions carefully.

II. RECEIVING

Receiving Inspection

When unit is received, inspect immediately for damaged or missing parts. Even though all units are carefully inspected and prepared for shipment at the factory, rough handling en route may cause concealed damage or cause nuts, set screws, bolts or locking collars to work loose. Be certain all fasteners are tightened securely. Rotate wheel by hand to verify that it rotates freely and that there are no obstructions.

Table #1

| TORQUE VALUES FOR SPLIT TAPER BUSHINGS | |
|--|---------------------------------------|
| Bushing Size | MINIMUM RECOMMENDED TORQUE (INCH-LBS) |
| H | 95 |
| B & P | 192 |
| Q & R | 350 |

Table #2

| SET SCREW TORQUE VALUES | | |
|--------------------------------|--------------------------------------|------------------------------------|
| SET SCREW SIZE | | MINIMUM REQUIRED TORQUE (INCH-LBS) |
| Diameter & No. of Threads/Inch | Hex Size Across Flats (Allen Wrench) | |
| 1/4-20 | 1/8" | 65 |
| 5/16-18 | 5/32" | 165 |
| 3/8-16 | 3/16" | 228 |
| 7/16-14 | 7/32" | 348 |
| 1/2-13 | 1/4" | 504 |
| 5/8-11 | 5/16" | 1104 |

NOTE: If wheel set screws are loosened and/or wheel is removed from shaft, set screws *must* be replaced. Set screws cannot be used more than once. Use knurled, cup point set screws with a locking patch.

Inspect all shipments carefully for damage. THE RECEIVER MUST NOTE ANY DAMAGE ON THE CARRIER'S BILL OF LADING AND FILE A CLAIM IMMEDIATELY WITH THE FREIGHT COMPANY IN THE CASE OF ANY DAMAGE. Keep a record of all equipment received, including inspection details and date of receipt because of the possibility of partial shipments.

III. HANDLING

Handle your equipment with care. Some fans are provided with lifting lugs or holes for easy handling. Others must be handled using nylon straps or well-padded chains and cables which protect the fan's coating and housing. Spreader bars should be used when lifting large parts.

Centrifugal fans are best lifted using one strap under the fan's scroll and another strap around the bearing base. DO NOT LIFT CENTRIFUGAL FANS BY THE FAN SHAFT, WHEEL, FLANGES OR INLET SUPPORT OR MOTOR EYE BOLT.

NOTICE

If fan will not be put into operation within 30 days, obtain long-term storage instructions from our website (www.cincinnati-fan.com) or your local Cincinnati Fan Sales Office.

IV. GENERAL INSTALLATION INSTRUCTIONS

Foundations

Fan foundation must be flat, level and rigid. Where foundation is not completely flat, shims must be placed under fan support at each anchor bolt as required. Bolting fan to an uneven foundation distorts alignment and causes vibration.

Structural steel foundations should be heavily cross-braced for load support.

V. OPERATION

Before Connecting Power

1. Inspect all fasteners and retighten if necessary:
 - a. Foundation bolts.
 - b. Set screws in fan and wheel and V-belt drive (See Tables #1 & #2 on preceding page).
 - c. Housing, bearing and motor mounting.
2. Inspection doors should be tight and sealed.
3. Bearings should be checked for alignment and lubrication (See Bearing Maintenance, pages 4 & 5).
4. Turn rotating assembly by hand to insure that it does not strike housing. If the wheel strikes the housing, the wheel may have moved on the shaft or the bearings may have shifted in transit. Correction *must* be made prior to start up.
5. Check motor to insure proper speed and electrical characteristics.
6. Check V-belt drive for alignment and correct belt tension.
7. After wiring, energize motor for one second to check for proper rotation.

VI. GENERAL MAINTENANCE

CAUTION

Before any maintenance or service is performed, assure that unit is disconnected or locked out from power source to prevent accidental starting.

The key to good fan maintenance is a regular and systematic inspection of all fan parts. Severity of the application should determine frequency of inspection. The components requiring service are generally the moving parts which include bearings, fan wheel, belts, sheaves and motor.

Cast Aluminum & Metal Parts

Cast aluminum and steel parts usually do not require maintenance during the life of the unit except painted metal surfaces that may require periodic repainting. In a severe, dirty operation, the wheel should be cleaned with a wire brush to prevent an accumulation of foreign matter that could result in fan unbalance. After cleaning wheel, inspect for possible cracks or excessive wear, which can cause unbalance. **DO NOT** operate a wheel that is cracked, chipped, has broken blades or excessive wear. NOTE: If wheel set screws are loosened and/or wheel is removed from shaft, set screws *must* be replaced. Set screws cannot be used more than once. Belts on V-belt drive units require periodic inspection and replacement when worn. For multiple belt drives, belts should be replaced with matched sets.

Motor Maintenance

1. Disconnect or lock out power to motor.
2. Removing dust and dirt: Blow out open type motor windings with low pressure air to remove dust or dirt. Air pressure above 50 P.S.I. should not be used as high pressure may damage insulation and blow dirt under loosened tape. Dust accumulation can cause excessive insulation temperatures.
3. Lubrication: The motor bearings and the fan bearings on the belt drive fans should be greased at regular intervals. Motor manufacturers' greasing instructions and recommendations should be followed closely. Avoid the use of a pressure greasing system which tends to fill the bearing chamber completely. Do not overgrease. Use only 1 or 2 shots with a hand gun in most cases. Maximum hand gun rating 40 P.S.I. Rotate bearings during lubrication where good safety practice permits. NOTE: On motors with non-regreasable sealed bearings, no lubrication is required for the life of the bearings.

To prevent rusting of bearing parts, the rotor must be rotated at regular intervals (30 days) to assure these parts are well covered with oil or grease.

VII. V-BELT DRIVES

Care should be taken not to overtighten V-belt drive. Excessive belt tension overloads fan and motor bearings. It is much less expensive to replace belts worn from slippage than to replace bearings damaged from excessive loading.

Fans shipped completely assembled have had V-belt drive aligned at the factory. Alignment should be rechecked before operation as a precaution due to handling during shipment.

**A WORD OF CAUTION
ABOUT MOTORS**

Using your hand to test the running temperature of a motor can be a very painful experience:

Normal body temperature98.6° F
 Threshold of pain caused by heat.....120.0° F
 Average temperature of hot tap water.....140.0° F
 Average temperature of hot coffee.....180.0° F
 Normal operating temperature of a fully loaded electric motor open type, 70° F ambient temperature174.0° F

1. Be sure sheaves are locked in position.
2. Key should be seated firmly in keyway.
3. Place straight edge or taut cord across faces of driving and driven sheaves to check alignment. The motor and fan shafts must be parallel with V-belts and at right angles to the shafts.
4. Start the fan. Check for proper rotation. Run fan at full speed. A slight bow should appear on slack side of belt. Disconnect power and adjust belt tension by adjusting motor on its sliding base. All belts must have some slack on one side.

5. If belts squeal at start up, they may be too loose.
6. When belts have had time to seat in the sheave grooves, then readjust belt tension. (2-3 days)

V-belt drive assembly can be mounted as follows:

1. Clean motor and fan shafts. Be sure they are free from corrosive material. Clean bore of sheaves and coat with heavy oil for ease of shaft entry. Remove oil, grease, rust or burrs from sheave grooves.
2. Place fan sheave on fan shaft and motor sheave on its shaft. **Do not pound sheaves** on as this may damage bearings. Tighten sheaves per Table #1 or #2 on page 2.

Table #3 (See Bearing Maintenance, page 5.)

| Conditions Around Bearing | Operating Temperature of Fan | **Greasing Intervals |
|--|--|--|
| Fairly Clean | up to 120 °F | 6-12 months |
| | 120°-160°F | 2-3 months |
| | 160°-200°F plus* | 1-2 months |
| Moderate to Extremely Dirty | up to 160°F | 1-2 months |
| | 160°-200°F plus* | 2-4 weeks |
| Cold Storage Room | | every defrosting period or no more than 4 months |
| *For fan applications over 200°F: greasing intervals should be from several days to 2 weeks, depending on the temperature. | | |
| **For vertical installations, greasing intervals should be twice as frequent as table values. | | |
| <hr/> The following greases, or one that is equivalent to the general description, are recommended for the following temperatures or excessive moisture applications. | | |
| Operating Conditions | Use Grease Equivalent to these Grades | |
| Temperatures -65°F to 0°F | Esso-Beacon #325 (-65°F) Mobil Grease #28 (-65°F) Shell Oil Aeroshell No. 7 (-100°F) | |
| General Description: Versatile multipurpose microgel thickened synthetic hydrocarbon grease with corrosion inhibitors, anti-oxidant additives, water resistance tendencies and EP characteristics. | | |
| Temperature 0°F to 200°F inclusive (Also use for heavy condensation or direct splash of water) | Mobil Oil - Mobilux EP #2 Shell Oil - Shell Alvania EP #2 Chevron - Chevron SRI #2 | |
| General Description: Multipurpose NLGI#2 grease from lithium soap with EP characteristics, rust inhibitors, anti-oxidant additives and good water resistance tendencies. | | |
| Temperatures over 200°F | Dow Corning-DC44 (400°F) (Not compatible with non-silicon based greases) | |
| General Description: Versatile multipurpose microgel thickened synthetic hydrocarbon grease with corrosion inhibitors, anti-oxidant additives, water resistance tendencies and EP characteristics. | | |

3. Move motor on slide base so belts can be placed in grooves of both sheaves without forcing. Do not roll belts or use a tool to force belts over the grooves.
4. Align fan and motor shafts so they are parallel. The belts should be at right angles to the shafts. A straight edge or taut cord placed across the face of the sheaves will aid in alignment.
5. Tighten belts by adjusting motor base. Correct tension gives the best drive efficiency. Excessive tension causes undue bearing pressure.
6. Start the fan and run it at full speed. Adjust belt tension until only a slight bow appears on the slack side of the belts. If slippage occurs, a squeal will be heard at start-up. Eliminate this squeal by **disconnecting or locking out motor from power source** and then tightening up the belts.
7. Give belts a few days running time to become seated in sheave grooves, then readjust belt tension.

If the shafts become scratched or marked, carefully remove sharp edges and high spots such as burrs with fine emery cloth or honing stone. Avoid getting emery dust in the bearings.

Do not apply any belt dressing unless it is recommended by the drive manufacturer. V-belts are designed for frictional contact between the grooves and sides of the belts. Dressing will reduce this friction.

Belt tension on an adjustable pitch drive is obtained by moving the motor, not by changing the pitch diameter of the adjustable sheave.

VIII. BEARING MAINTENANCE

Sealed Bearings

Sealed for life bearings are pre-lubricated with the correct amount of manufacturer approved ball bearing grease, and are designed for application where relubrication is not required.

Relubricatable Bearings

The motor bearings and fan bearings on belt drive fans should be greased at regular intervals. Motor manufacturers greasing instructions and recommendations should be followed closely. Avoid the use of a pressure greasing system which tends to fill the bearing chamber completely. Do not over grease.

NOTE: On motors with non-regreasable, sealed bearings, no lubrication is required for the life of the bearing.

Table #3 (page 4) lists the time intervals between fan greasing to insure proper lubrication in adverse conditions of heat and dust. Use only 1 or 2 shots with a handgun in most cases. Maximum handgun rating 40 P.S.I.

IX. WARRANTY

Cincinnati Fan & Ventilator Company warrants products of its own manufacture against defects of material and workmanship under normal use and service for a period of eighteen (18) months from date of shipment or twelve (12) months from date of installation, whichever occurs first.

This warranty does not cover ordinary wear and tear, abuse, misuse, overloading, negligence, alteration or systems and/or materials not of Seller's manufacture. Expenses incurred by Buyer(s) in repairing or replacing any defective product will not be allowed except where authorized in writing and signed by an officer of the Seller.

The obligation of Seller under this warranty shall be limited to repairing or replacing F.O.B. Seller's plant, or allowing credit at Seller's option. This warranty is expressly in lieu of all other warranties expressed or implied including the warranties of merchantability and fitness for use and of all other obligations and liabilities of the Seller. The Buyer acknowledges that no other representations were made to him or relied upon him with respect to the quality or function of the products herein sold.

On equipment furnished by the Seller, but manufactured by others, such as motors, Seller extends the same warranty as Seller receives from the manufacturer thereof. Repairs for motors should be obtained from nearest authorized motor service station for the make of motor furnished. All motors used are products of well-known manufacturers with nationwide service facilities. Check the yellow pages of your telephone directory for the location of the nearest service shop.

Cincinnati Fan & Ventilator Company assumes no responsibility for material returned to our plant without our prior written permission.

X. ORDERING REPLACEMENT PARTS

Replacement or spare parts may be ordered through your local Cincinnati Fan representative. (Refer to drawings that begin on page 7.) The following information should accompany parts orders:

1. Motor horsepower, frame size, motor speed, voltage, phase, cycle and enclosure. Motor manufacturer's model number from motor nameplate.
2. Fan Speed (if V-belt driven).
3. Fan serial **and** model numbers from the **fan** nameplate and a complete description of the part.

An adequate stock of repair parts is maintained where possible. **If your fan is vital to production or to plant operation, it is advisable to have all spare parts on hand to minimize downtime.**

XI. TROUBLE SHOOTING

In the event that trouble is experienced in the field, the following are the most common fan difficulties. These points should be checked in order to prevent needless delay and expense.

1. CAPACITY OR PRESSURE BELOW RATING

- a. Incorrect direction of wheel rotation.
- b. Speed too slow.
- c. Dampers not properly adjusted.
- d. Poor fan inlet or outlet conditions (elbows, restrictions).
- e. Air leaks in system.
- f. Damaged wheel.
- g. Total resistance of system higher than anticipated.
- h. Wheel mounted backwards on shaft.
- i. Fan not properly selected for a high temperature and/or high altitude application.

2. VIBRATION AND NOISE

- a. Misalignment of bearings, coupling, wheel or V-belt drive.
- b. Unstable foundation or supports.
- c. Foreign material in fan causing unbalance.
- d. Worn bearings.
- e. Damaged wheel or motor.
- f. Broken or loose bolts and set screws.
- g. Bent shaft.
- h. Worn coupling.
- i. Fan wheel or drive unbalanced.

- j. 120 cycle magnetic hum due to electrical input. Check for high or unbalanced voltage.
- k. Fan delivering more than rated capacity.
- l. Loose dampers.
- m. Speed too high or fan rotating in wrong direction.
- n. Vibration transmitted to fan from some other source.

3. OVERHEATED BEARINGS

- a. Check bearing lubrication.
- b. Poor alignment.
- c. Damaged wheel or drive.
- d. Bent shaft.
- e. Abnormal end thrust.
- f. Dirt in bearings.
- g. Excessive belt tension.

4. OVERLOAD ON MOTOR

- a. Speed too high.
- b. Fan over capacity due to existing system resistance being lower than original rating.
- c. Specific gravity or density of gas above design value.
- d. Wrong direction of wheel rotation.
- e. Shaft bent.
- f. Poor belt alignment.
- g. Wheel wedging or binding on fan housing.
- h. Bearings improperly lubricated.
- i. Motor improperly wired.
- j. Defective motor. Motor must be tested by motor manufacturer's authorized repair shop.

MODEL HP
Arrangement 4

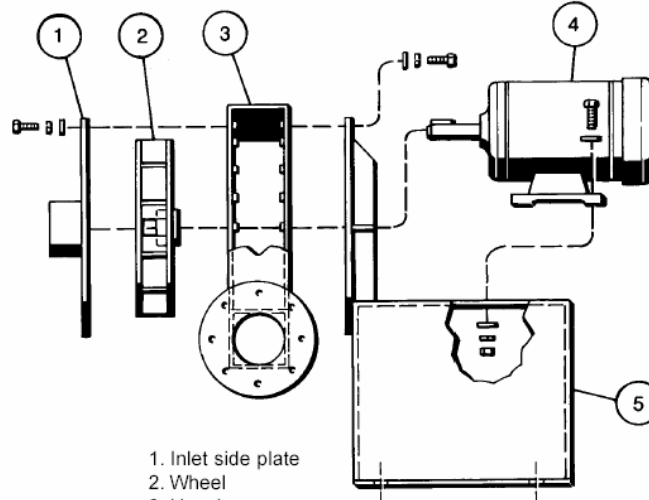

- 1. Inlet side plate
- 2. Wheel
- 3. Housing
- 4. Motor
- 5. Base

NOTE: Shaft seal is not shown

MODELS HDBI, HDAF and RBE
Arrangement 4

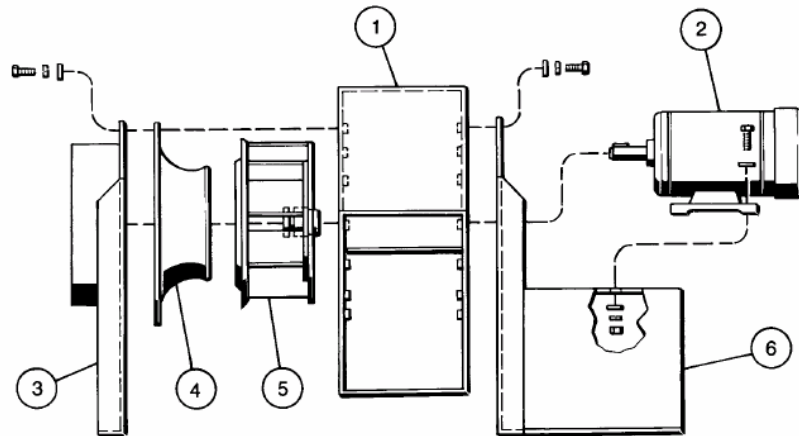

- 1. Housing
- 2. Motor
- 3. Inlet side plate
- 4. Inlet bell (on models HDBI and HDAF only)
- 5. Wheel (HDBI wheel shown)
- 6. Base

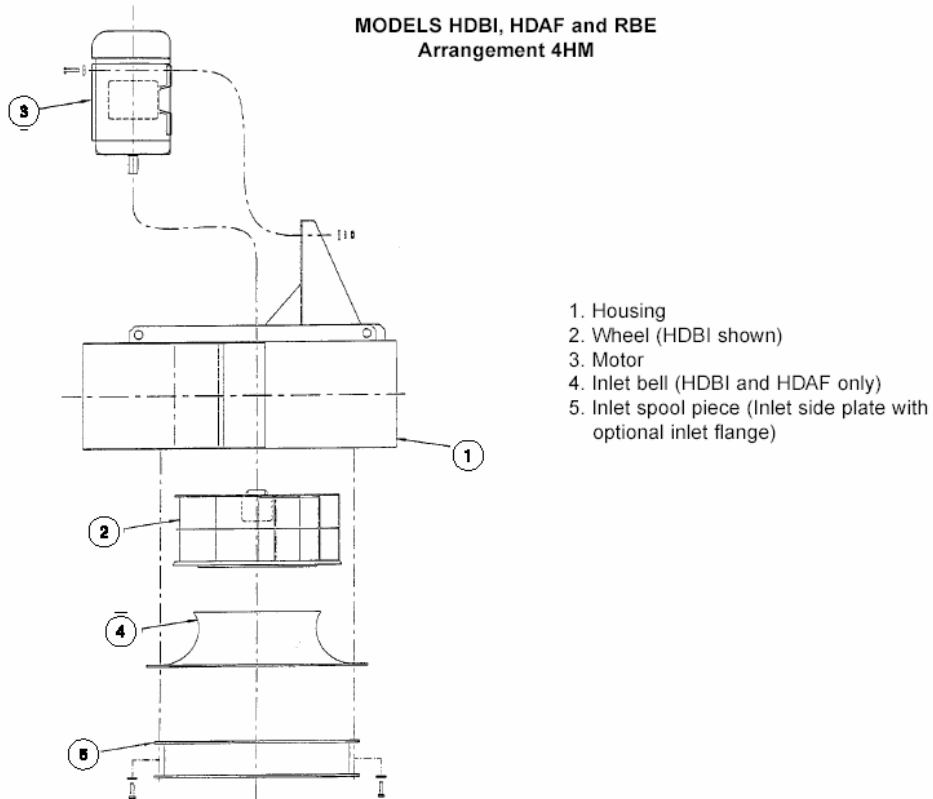

**MODELS HDBI, HDAF and RBE
Arrangements 1 and 9**

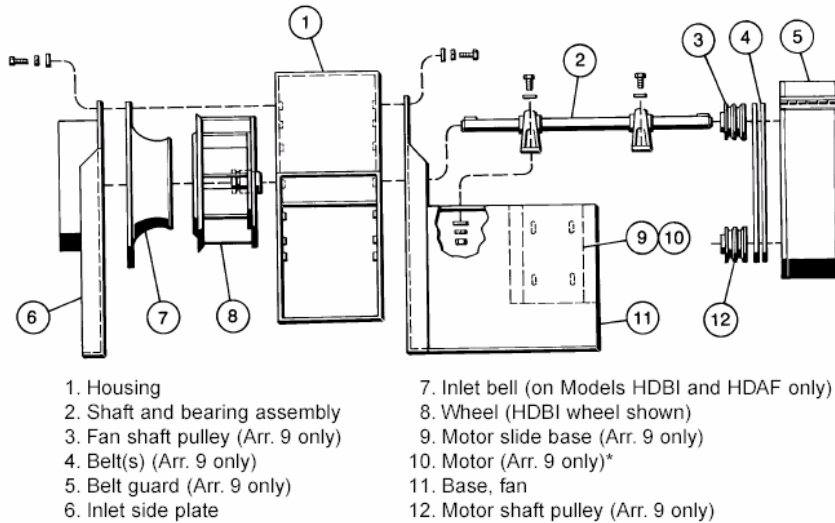

* Motor not shown in figure

MODELS HDBI, HDAF and RBE
Arrangement 9CB Channel Base

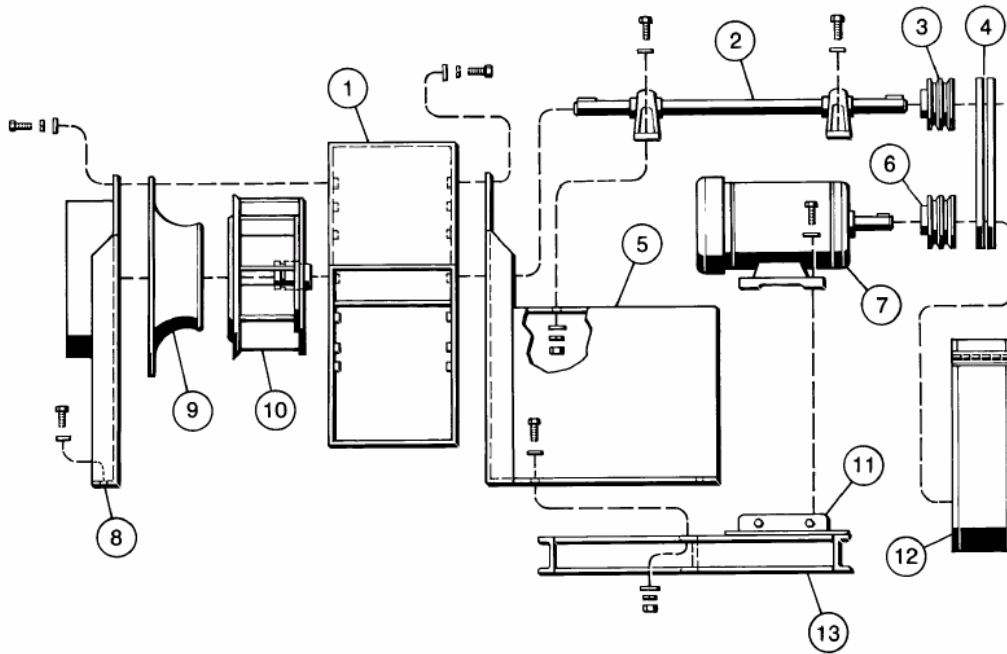

1. Housing
2. Shaft and bearing assembly
3. Fan shaft pulley
4. Belt(s)
5. Base, fan
6. Motor shaft pulley
7. Motor
8. Inlet side plate
9. Inlet bell (on Models HDBI and HDAF only)
10. Wheel (HDBI wheel shown)
11. Motor slide base
12. Belt guard
13. Base, Channel

MODELS HDBI, HDAF and RBE
Arrangement 10

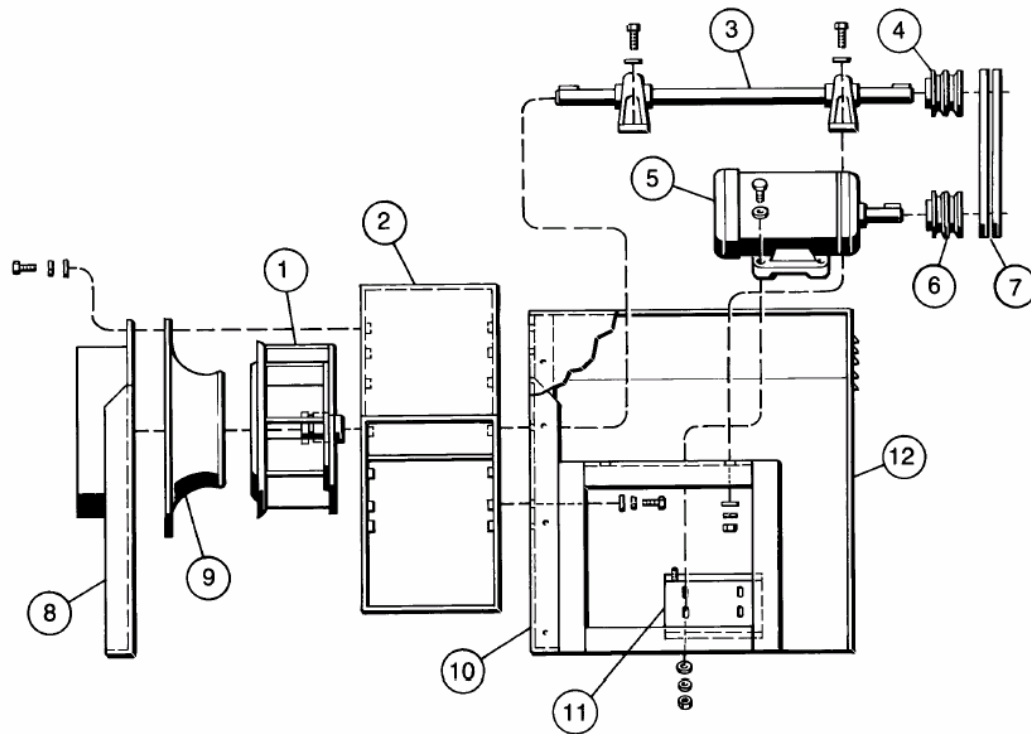

1. Wheel (HDBI wheel shown)
2. Housing
3. Shaft and bearing assembly
4. Fan shaft pulley
5. Motor
6. Motor shaft pulley
7. Belt(s)
8. Inlet side plate
9. Inlet bell (on Models HDBI and HDAF only)
10. Base, fan
11. Motor base
12. Weather cover

MODEL HP
Arrangement 1 and 9

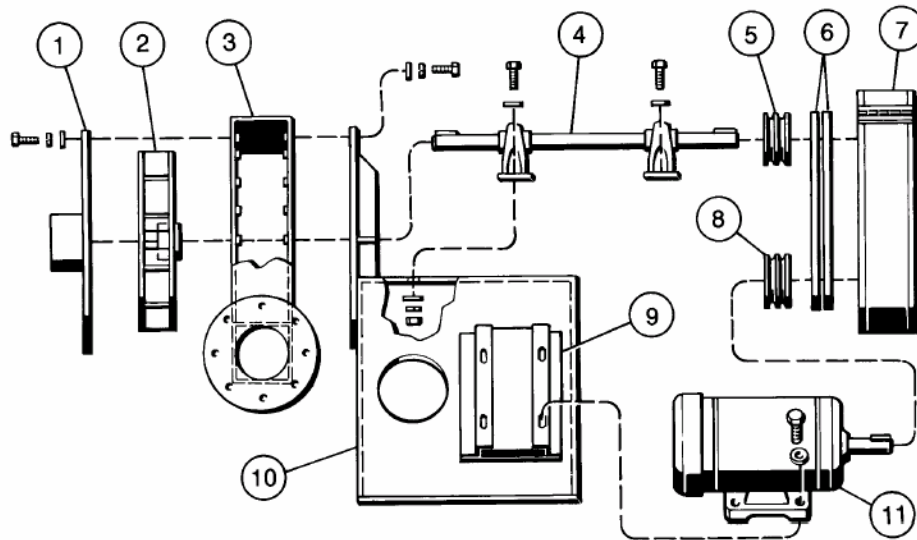

1. Inlet side plate
2. Wheel
3. Housing
4. Shaft and bearing assembly
5. Fan shaft pulley (Arr. 9 only)
6. Belt(s) (Arr. 9 only)
7. Belt guard (Arr. 9 only)
8. Motor shaft pulley (Arr. 9 only)
9. Motor slide base (Arr. 9 only)
10. Base, fan
11. Motor (Arr. 9 only)

NOTE: Shaft seal is not shown

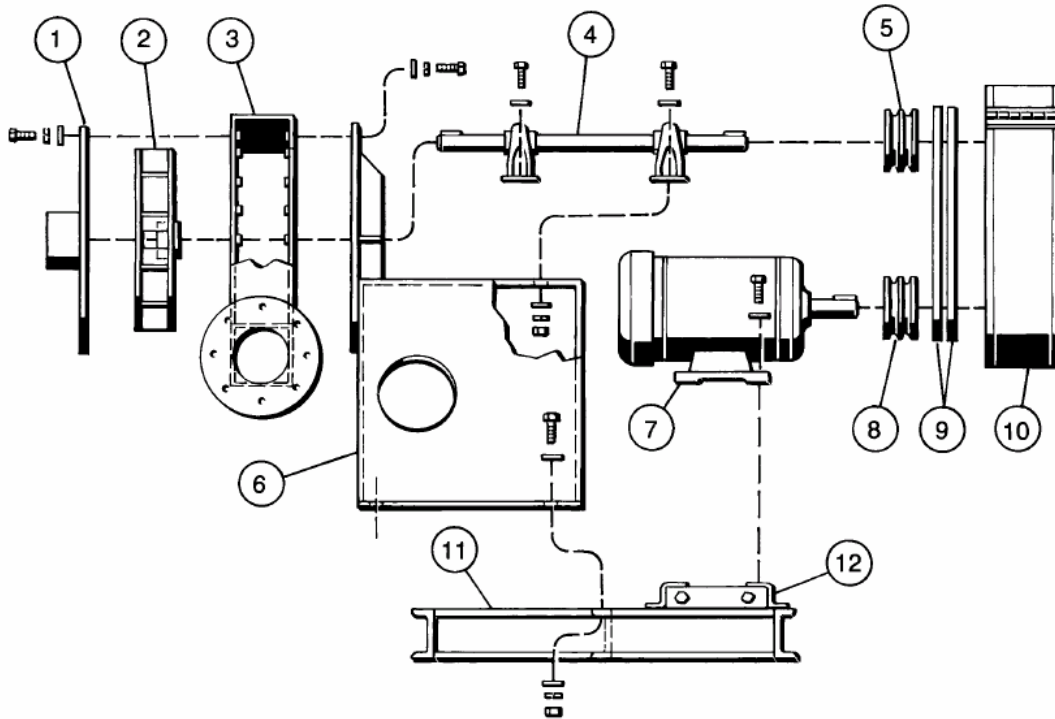
MODEL HP
Arrangement 9CB Channel Base

1. Inlet side plate
2. Wheel
3. Housing
4. Shaft and bearing assembly
5. Fan shaft pulley
6. Base, fan
7. Motor
8. Motor shaft pulley
9. Belt(s)
10. Belt guard
11. Base, channel
12. Motor slide base

Note: Shaft seal is not shown.

9.2: Rotary airlock

P. O. Box 2098, Martinsville, VA 24113
E-Mail Address: koger@kogerair.com
Website: www.kogerair.com

AIR-LOC LIMITED WARRANTY

All parts manufactured by Koger are guaranteed for a period of twelve (12) months from the date of shipment to be free of defects in material or workmanship.

If the parts should become defective from normal use and service within the twelve month period, Koger will elect to repair or replace the parts free of charge provided the defective parts are properly identified and shipped by purchaser, with all transportation charges prepaid, in accordance with return instructions furnished in each instance by Koger.

Replacement parts manufactured by Koger also will be guaranteed for a period of twelve months from the date of shipment.

Parts manufactured by others but furnished by Koger carry the same guarantee as we received from the manufacturer thereof.

THIS WARRANTY DOES NOT COVER:

- (1) Defects of malfunctions due to failure to follow maintenance and lubricating instructions;
- (2) Damages or defects due to misuse, alteration, negligence or accident;
- (3) Products or parts which have been altered, changed or repaired by someone other than Koger without our written consent;
- (4) Defects due to incidental or consequential damages of any kind;
- (5) Defects or damages due to improper application or installation by purchaser.

This warranty to repair or replace the defective equipment is the only warranty, either express, implied or statutory, and our liability is expressly limited to the repair of the furnishing of replacement parts, and we shall not be liable for any expense, injury, loss or damage, whether direct or consequential, including but not limited to loss of profits, production, increased cost of operation, spoilage of material, or any delay arising in connection with the sale or use of, or inability to use our equipment or products for any purpose. All other damage and warranties are hereby expressly waived by the purchaser.

a/198

Telephone: 1-800-368-2096 • FAX: 1-800-554-4040



P. O. Box 2098, Martinsville, VA 24113
E-Mail Address: koger@kogerair.com
Website: www.kogerair.com

AIR-LOC OPERATING MANUAL

Check the direction of Air-Loc's rotation by watching the painted end shaft in relation to the indication arrow. If the Air-Loc rotates in the wrong direction, stop power to motor, lockout, and interchange any two line leads on motor. Operate for a minimum of one hour. During this period, check for any unusual noise in speed reducer or thermal conditions in the motor. Check the actual operation current of the motor noted on the nameplate to be sure that the current times service factor is not exceeded in order to maintain steady loads. The plug-in shaft arrangement between C-face motor and speed reducer provides a unique direct connection. A special brass liner with a fluorocarbon coating helps prevent corrosion.

NOTE: Koger Air-Locs are tested for a period of not less than eight hours before approved for shipment.

LUBRICATION

Air-Locs are pre-filled with 90 weight gear oil before testing in our plant. After installing, be sure to check oil levels before start-up.

Refer to the enclosed manufacturers' specifications on bearings and gear drives.

a/198

Telephone: 1-800-368-2096 • FAX: 1-800-554-4040



REPLACEMENT PARTS LIST

- Reducer/Motor-Grove Sp/CMR2062/Leeson 2 Hp
- Bearing - Dodge F4BSC115 1 15/16"
- Sprocket (Drive) UST 60BS17 - 1 1/4" Bore
- Sprocket (Driven) UST 60BS40 - 1 15/16" Bore
- Chain - UST #60 Riveted
- Rubber Wiper (4) 9 3/16" x 15 3/8" x 3/8" Belting

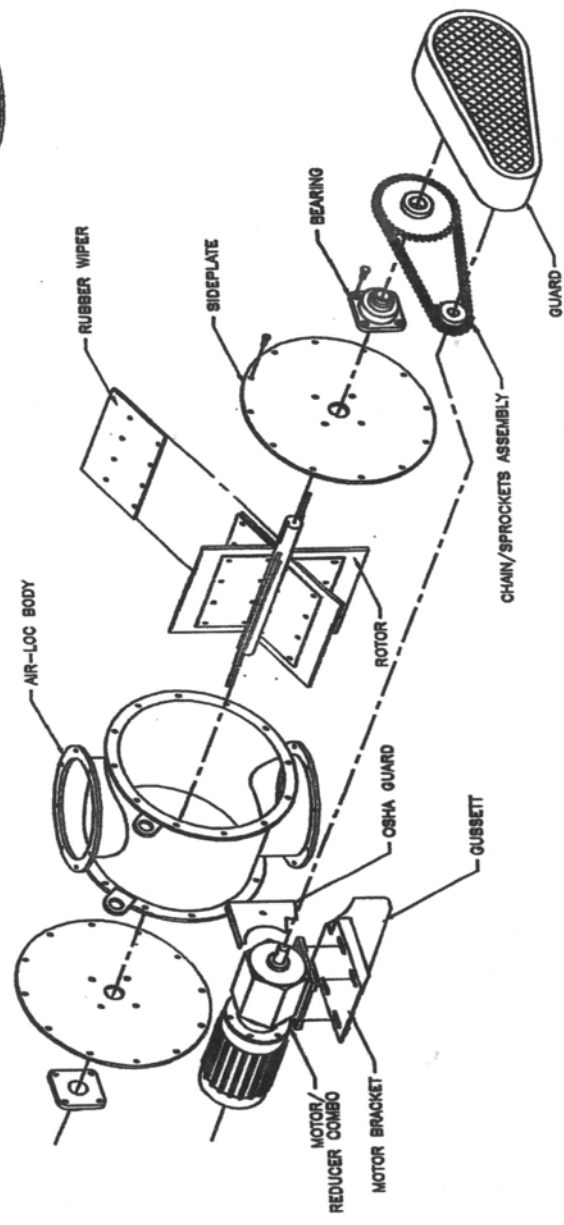

KOGER
 MARTINSVILLE, VIRGINIA
 12" AIR-LOC PARTS
 THIS DRAWING IS THE PROPERTY OF
 P.O. BOX 2098
 MARTINSVILLE, VA 24113

WEBSITE: www.kogerair.com
 E-MAIL ADDRESS:
KOGER@KOGERAIR.COM

P. O. BOX 2098
 MARTINSVILLE, VA 24113
 PHONE: 800-368-2096
 FAX: 800-554-4040



REPLACEMENT PARTS LIST

Reducer/Motor-Grove Sp/CMR2062/Leeson 2 Hp
 Bearing - Dodge F4BSC115 - 1 15/16"
 Sprocket (Drive) UST 60BS17 - 1 1/4" Bore
 Sprocket (Driven) UST 60BS40 - 1 15/16" Bore
 Chain - UST #60 Riveted
 Rubber Wiper (4) 9 3/16" x 13 3/8" x 3/8" Belting

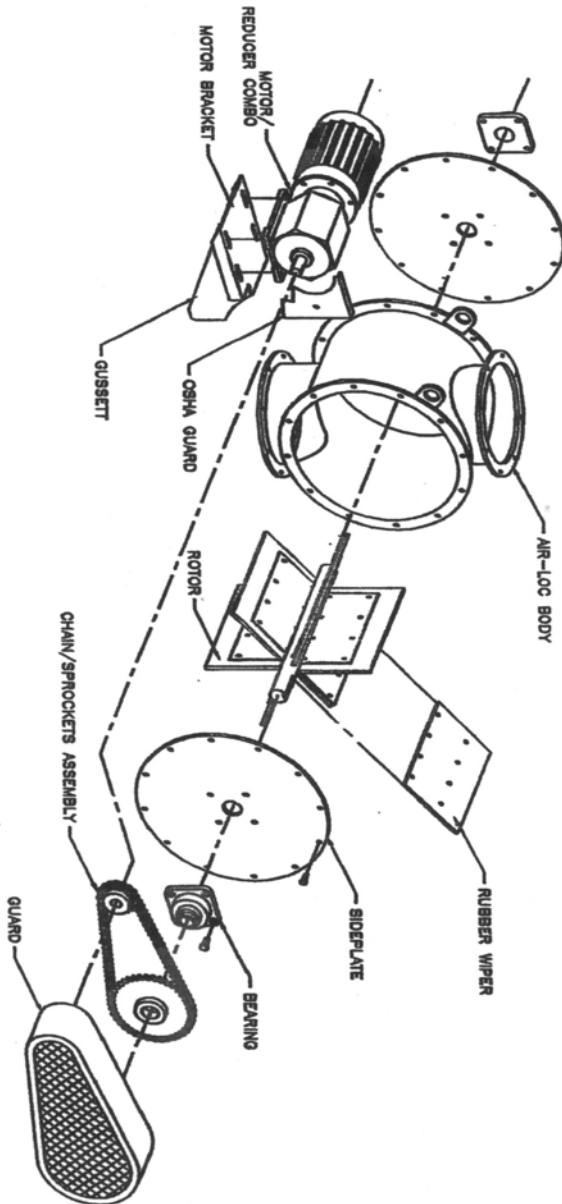

P. O. BOX 2098
 MARTINSVILLE, VA 24113
 PHONE: 800-368-2096
 FAX: 800-554-4040

WEBSITE: www.koggerair.com
 E-MAIL ADDRESS:
KOGGER@KOGGERAIR.COM

KOGGER
 MARTINSVILLE, VIRGINIA
 10" AIR-LOC PARTS
 THIS DRAWING IS THE PROPERTY OF
 KOGGER
 P. O. BOX 2098
 MARTINSVILLE, VA 24113

GROVE GEAR

TorqueLine[™]
Helical Gear Drives





**Installation,
Lubrication and
Maintenance
Instructions**

CONGRATULATIONS!

Your decision to purchase a world class reducer from Grove Gear will provide you with many years of trouble free service if you adhere to the following installation and maintenance instructions.

IMPORTANT INFORMATION**Please Read Carefully**

The following  and  information is supplied to you for your protection and to provide you with many years of trouble free and safe operation of your Grove Gear product.

Read **ALL** instructions prior to operating reducer. Injury to personnel or reducer failure may be caused by improper installation, maintenance or operation.



- Written authorization from Grove Gear is required to operate or use reducers in man lift or people moving devices.
- Check to make certain application does not exceed the allowable load capacities published in the current catalog.
- Buyer shall be solely responsible for determining the adequacy of the product for any and all uses to which Buyer shall apply the product. The application by Buyer shall not be subject to any implied warranty of fitness for a particular purpose.
- For safety, Buyer or User should provide protective guards over all shaft extensions and any moving apparatus mounted thereon. The User is responsible for checking all applicable safety codes in his area and providing suitable guards. Failure to do so may result in bodily injury and/or damage to equipment.
- Hot oil and reducers can cause severe burns. Use extreme care when removing lubrication plugs and vents.
- Make certain that the power supply is disconnected before attempting to service or remove any components. Lock out the power supply and tag it to prevent unexpected application of power.
- Reducers are not to be considered fail safe or self-locking devices. If these features are required, a properly sized, independent holding device should be utilized. Reducers should not be used as a brake.
- Any brakes that are used in conjunction with a reducer must be sized or positioned in such a way so as to not subject the reducer to loads beyond the catalog rating.
- Lifting supports including eyebolts are to be used for vertically lifting the gearbox only and no other associated attachments or motors.
- Use of an oil with an EP additive on units with backstops may prevent proper operation of the backstop. Injury to personnel, damage to the reducer or other equipment may result.
- Overhung loads subject shaft bearings and shafts to stress which may cause premature bearing failure and/or shaft breakage from bending fatigue, if not sized properly.



- Test run unit to verify operation. If the unit tested is a prototype, that unit must be of current production.
- If the speed reducer cannot be located in a clear and dry area with access to adequate cooling air supply, then precautions must be taken to avoid the ingestion of contaminants such as water and the reduction in cooling ability due to exterior contaminants.
- Mounting bolts should be routinely checked to ensure that the unit is firmly anchored for proper operation.

In the event of the resale of any of the goods, in whatever form, Resellers/Buyers will include the following language in a conspicuous place and in a conspicuous manner in a written agreement covering such sale:

The manufacturer makes no warranties or representations, express or implied, by operation of law or otherwise, as to the merchantability or fitness for a particular purpose of the goods sold hereunder. Buyer acknowledges that it alone has determined that the goods purchased hereunder will suitably meet the requirements of their intended use. In no event will the manufacturer be liable for consequential, incidental or other damages. Even if the repair or replacement remedy shall be deemed to have failed of its essential purpose under Section 2-719 of the Uniform Commercial Code, the manufacturer shall have no liability to Buyer for consequential damages.

Reseller/Buyers agree to also include this entire document including the warnings and cautions above in a conspicuous place and in a conspicuous manner in writing to instruct users on the safe usage of the product.

This information should be read together with all other printed information supplied by Grove Gear.

Instruction Manual**GROVE GEAR****General Operation**

1. Run the motor which drives the reducer and check the direction of reducer output rotation. Consult motor nameplate for instructions to reverse the direction of rotation.
2. Attaching the load: On direct coupled installations, check shaft and coupling alignment between speed reducer and loading mechanism. On chain/sprocket and belt/pulley installation, locate the sprocket or pulley as close to the reducer as possible to minimize overhung load. Check to verify that the overhung load does not exceed specifications published in the catalog.

WARNING Overhung loads subject shaft bearings and shafts to stress which may cause premature bearing failure and/or shaft breakage from bending fatigue, if not sized properly.

3. **WARNING** High momentum loads: If coasting to a stop is undesirable, a braking mechanism should be provided to the speed reducer output or the driven mechanism. **The reducer should not be used as a brake.**

CAUTION The system of connected rotating parts must be free from critical speed, torsional or other type vibration, no matter how induced. The responsibility for this system analysis lies with the purchaser of the speed reducer.

Installation

1. Mount the unit to a rigid flat surface using grade 5 or higher fasteners. The mounting fasteners should be the largest standard size that will fit in the base mounting hole. Shim as required under flange or base feet which do not lie flat against the mounting surface.
2. For shipment, pipe plugs are installed in the unit and a vent plug is packed separately. After mounting the unit in position, remove the appropriate pipe plug and install the vent plug in the location shown on page 5. On quad reduction units both the primary and the secondary housings must be vented. Failure to vent the unit can cause premature seal wear or loss of seal and oil. These conditions are not covered by warranty. Check for correct oil level. Contact the factory for level and vent recommendations on non-standard mounting positions.
3. Connect motor to speed reducer. Check to ensure that the voltage range specified on the motor corresponds to the supply voltage. Wiring instructions are normally given on the motors, but if in doubt, reference should be made to the particular manufacturer's handbook.

CAUTION If the mounting position is changed, the oil quantity must be adjusted to obtain the proper oil level per these Lubrication Instructions. Mounting position must be one shown on page 5. Consult the factory if you are not certain of the correct oil level or quantity. Consult the factory for mounting positions not shown.

CAUTION Do not operate the reducer without making sure it contains the correct amount of oil. Do not overfill or underfill with oil, or injury to personnel, reducer or other equipment may result.

CAUTION A unit cannot be used as an integral part of a machine superstructure which would impose additional loads on the unit other than those imposed by the torque being transmitted either through a shaft-mounted arrangement, or any shaft mounted power transmitting device. (*e.g. sprockets, pulleys, couplings*)

CAUTION For safe operation and to maintain the unit warranty, when changing a factory installed fastener for any reason, it becomes the responsibility of the person making the change to properly account for fastener grade, thread engagement, load, tightening torque and the means of torque retention.

CAUTION When the gear units are used in conjunction with any auxiliary equipment, care must be taken to ensure proper alignment is achieved.

CAUTION Use a flexible coupling with this gear unit. Do not use a solid coupling. Any coupling, pulley, gear wheel or sprocket fitted to the shaft of this unit must be fitted by utilizing the tapped hole provided in the final shaft. It must **NOT** be driven on as this may cause internal damage to gears and bearings.

Instruction Manual **GROVE GEAR**

Lubrication

All standard reducers ordered from the factory are filled with lubricant to the correct level for the mounting position specified to operate within a 30° to 125° F ambient temperature range. Quad reduction units have separate oil sumps and must be filled/checked independently. Prior to startup, verify that the oil is at the level shown on the drawings on page 5. If the ambient temperature will be outside the range for the lubricant installed at the factory, drain and refill the reducer with the proper viscosity lubricant prior to use.

CAUTION If the mounting position is changed, the oil quantity must be adjusted to obtain the proper oil level per these Lubrication Instructions. Mounting position must be one shown on page 5. Consult the factory if you are not certain of the correct oil level or quantity. Consult the factory for mounting positions not shown.

CAUTION In the Food and Drug Industry (including animal food), consult the lubrication supplier for recommendation of lubricants which are acceptable to the Food and Drug Administration and/or other authoritative bodies having jurisdiction. Factory supplied oil is not suitable for these applications or this industry.

CAUTION Do not mix different oils in the reducer. Oil should be compatible with Nitrile seal material.

WARNING Use of an oil with an EP additive on units with backstops may prevent proper operation of the backstop. Injury to personnel, damage to the reducer or other equipment may result.

Change Intervals: After the first 500 hours or one month in service, whichever comes first, drain the oil from the reducer. Flush and refill with new oil. TorqueLine units utilize extreme pressure lubricants which protect the teeth in the event of the oil thinning out due to local temperature rise, or high pressure due to accidental overloads. These oils are liable to form sludge after continuous service. The oil should be changed after every 1500 hours of operation, or more often as conditions may dictate. The grades of oil shown below are for normal conditions of duty and ambient temperature. High ambient temperatures cause the oil to thin out and reduce its protective qualities. In such cases it will be necessary to utilize heavier grades than shown. Conversely, low temperatures will necessitate a thinner grade, otherwise trouble may be experienced with burning out of motors at starting. In this connection, the pour point of the oil must be less than the lowest ambient temperature to be encountered.

The precision-made gears and bearings in Grove Gear Speed Reducers require high-grade lubricants of the proper viscosity to maintain trouble-free performance. For best results, use lubricants on the following chart for TorqueLine gear reducers for ambient temperatures of 30° to 125° F.

| Mobil Corporation | Chevron Corporation | Texaco Inc. | Citgo Petroleum Corporation | Shell Group of Companies | Castrol Limited |
|-------------------|-------------------------|-------------|-----------------------------|--------------------------|-----------------|
| Mobilgear 630 | Gear Compound EP ISO220 | Meropa 220 | EP Compound 220 | Omala 220 | Alpha SP220 |

Approximate Oil Capacity (Pints) Double and Triple Reduction

| Model Type | Mounting Position | UNIT SIZE (Foot or Flange Mount) | | | | | | | | | |
|---|-------------------|----------------------------------|------|------|------|------|------|------|------|------|------|
| | | 2032 | 2042 | 2043 | 2062 | 2063 | 2072 | 2073 | 2082 | 2083 | 2092 |
| C-Frame or Gearmotor Models (HI20XXE) (HI20XXG) | B3, B5 Floor | Permanently Grease Lubed | 1 | 2 | 1.6 | 4.1 | 5.1 | 8.1 | 7.6 | 13.7 | 16.9 |
| | B8 Ceiling | | 1.8 | 2 | 3 | 4.2 | 7.4 | 7.6 | 11.4 | 11.8 | 20.1 |
| | B6, B7 Wall | | 1.5 | 1.7 | 2.3 | 3 | 6.1 | 5.5 | 10.1 | 10.1 | 19.6 |
| | V5, V1 Vertical | | 1.4 | 2.8 | 2.3 | 4.7 | 5.5 | 9.5 | 10 | 15.8 | 26.4 |
| Shaft Input Models (HI20XXA) (HI20XXC) | B3, B5 Floor | | 1.9 | 2.6 | 3 | 4.9 | 7.5 | 9.1 | 11.8 | 15.4 | 26.2 |
| | B8 Ceiling | | 2.2 | 2.2 | 3.1 | 4.3 | 7.8 | 8.6 | 13.2 | 12.9 | 23.3 |
| | B6, B7 Wall | | 1.6 | 1.9 | 2.4 | 3.1 | 6.1 | 7.1 | 11 | 10.8 | 21.6 |
| | V5, V1 Vertical | | 2.5 | 2.8 | 3.6 | 4.7 | 7.9 | 9.5 | 13.7 | 15.8 | 36.2 |

Approximate Oil Capacity (Pints) Quad Reduction

Quad reduction units are compound units, and the primary and secondary units are filled separately. Refer to the model table below and use the oil capacities in the table above.

| Unit Size | 2064 | 2074 | 2084 | |
|---------------------|------|------|------|---|
| Primary Unit Size | 2042 | 2062 | 2072 | (use primary oil capacities for desired Input type) |
| Secondary Unit Size | 2062 | 2072 | 2082 | (use secondary oil capacities for C-Frame Input) |

Instruction Manual **GROVE GEAR**

Mounting Position, Fill, Level and Drain Locations

Foot Mounted Reducers and Gearmotors

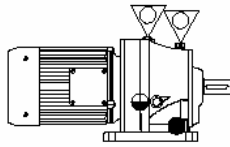

B3 - Standard Floor

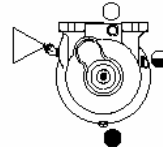

B8 - Ceiling

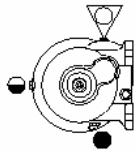

B7 - RH Wall

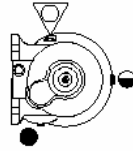

B6 - LH Wall

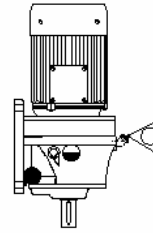

V5 - Vertical Down

Flange Mounted Reducers and Gearmotors

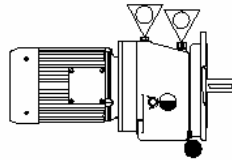

B5 - Horizontal

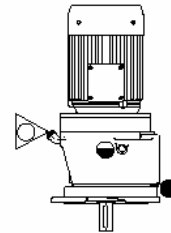

V1 - Vertical Down

Breather ○ Filler ▽ Filler/Breather ▽ Level ● Drain ●

16 oz. = 1 pint
 2 pints = 1 quart
 4 quarts = 1 gallon
 1 gallon = 128 oz. = 231 cu. in.

Always check for proper oil level after filling. Capacities vary somewhat with model and mounting position. Oil should rise to the center of the sight gage. Do not overfill.

Instruction Manual

Maintenance

Your Grove Gear reducer has been tested and adjusted at the factory. Dismantling or replacement of components must be done by Grove Gear to maintain the warranty.

Frequently check the oil level of the reducer. If oil level is low, (refer to reducer vent and level position chart) add proper lubrication through the filler plug until it comes to the center of the sight gage.

Inspect vent plug often to insure it is clean and operating.

 **CAUTION** Mounting bolts should be routinely checked to ensure that the unit is firmly anchored for proper operation.

Seals: The Grove Gear line of speed reducers utilize premium quality seals which are the state-of-the-art in sealing technology. Seals are, however, a wear item and eventually need to be replaced. Replacement can be easily accomplished by following the steps below:

 **WARNING** 1. Lock out and tag out the reducer's power source.

 **CAUTION** 2. Remove any load from the input and/or output shafts of the reducer prior to disconnecting any drive components.

3. Remove appropriate drive components to gain access to seal to be replaced.
4. Drain oil if seal is below oil level.
5. Remove the worn seal without damaging the shaft surface or the seal bore. This can be done by puncturing an approximate .062 diameter hole in the seal casing using an awl (being careful not to strike the bearing behind the seal). Screw a #10 sheet metal screw into the hole and pry out the seal.
6. Clean the seal bore of sealant.
7. Before installing the new seal, use electrical tape to cover any keyways on the shaft to prevent seal lip damage.
8. Grease the seal lips with bearing grease and apply a sealant to the seal bore in housing or cover.
9. Slide the seal onto the shaft being careful not to fold the inner lip over on any shaft steps.
10. Press the seal into its bore with a sleeve that presses on the seal casing, being careful to keep the seal square in its bore.
11. Refill reducer to proper level with appropriate lubricant.
12. Reconnect any drive components disconnected in Step 3. Make sure components are properly aligned.

Class of Service

All capacity ratings are based on proper application of American Gear Manufacturers Association (AGMA) service factors as given on page 226 - 227 of the TorqueLine Catalog. Load conditions must be within cataloged ratings published in the current Grove Gear Catalog (available upon request).

Warranty From Grove Gear - See catalog pages 230 - 231 for warranty terms and conditions.

For more information contact:

GROVE GEAR

A REGAL-BELOIT Company

1524 15th Avenue • Union Grove, WI 53182

Phone: 262-878-1221 • Fax: 262-878-1968

www.grovetgear.com • Email: sales@grovetgear.com

3240G/2M/8-01/BP/BH

Section 10.0: Warranty and Returns

10.1: Warranty

The Seller warrants that the products sold hereunder conform to any applicable drawings and specifications accepted in writing by Seller and will be free from any defects in material and workmanship which become apparent under normal use, and of which Buyer gives written notice to Seller within a period of 6 months from the date of installation or 12 months from the date of shipment, whichever period first expires. If, within that period, the Seller receives from Buyer written notice of any alleged defect in or non-conformance of any product and if, in Seller's sole judgement, the product does not conform or is found to be defective in material or workmanship, then Buyer shall, at Seller's request, return the part or product F.O.B. Seller's shipping point and Seller, at its option and expenses, shall repair or replace the defective part or product or repay the Buyer the full price paid for such part or product by Buyer.

Dismounting and reinstallation of defective or non-conforming parts is done on Buyer's expense. Warranty for delivery of spare parts or replacement of non-conforming parts expires when warranty for original equipment expires. Any repayment of purchase price shall be without interest. Seller's sole responsibility, and Buyer's exclusive remedy hereunder shall be limited to such repair, replacement, or repayment of the purchase price as above provided. THERE ARE NO OTHER WARRANTIES, EXPRESSED, STATUTORY OR IMPLIED, INCLUDING OF MERCHANTABILITY, QUALITY OR FITNESS FOR PURPOSE, NOR ANY AFFIRMATION OF FACT OR REPRESENTATION WHICH EXTENDS BEYOND THE DESCRIPTION ON THE FACE HEREOF. The warranties of Seller do not cover and Seller makes no warranty with respect to:

- a) failures not reported to Seller within the warranty period specified above;
- b) failure or damage due to misapplication, abuse, improper installation or abnormal conditions of temperature, dirt or corrosive matter;
- c) failures due to operation, either intentional or otherwise, above rate capacities or in an otherwise improper manner;
- d) products which have been in any way tampered with or altered by anyone other than an authorized representative of Seller;
- e) products damaged in shipment or otherwise without fault of Seller;
- f) expenses incurred by Buyer in an attempt to repair or rework any alleged defective product, and
- g) defects in material and workmanship which are attributable to drawings and specifications provided by Buyer.

10.1: Returns

Please contact DANTHERM customer service if you feel a part needs to be returned. Upon approval by DANTHERM, a return goods authorization number (RGA#) will be issued. Upon receipt, the number must be indicated on the return package. All returns are to be sent to the address below.

DANTHERM FILTRATION
102 Transit Ave.
PO Box 429
Thomasville, NC 27361-0429
Telephone: (800) 533-5286
Fax: (336) 821-0890