

Caterpillar Engine System SO-17988

M4127 - M4128 MIST CONNECT

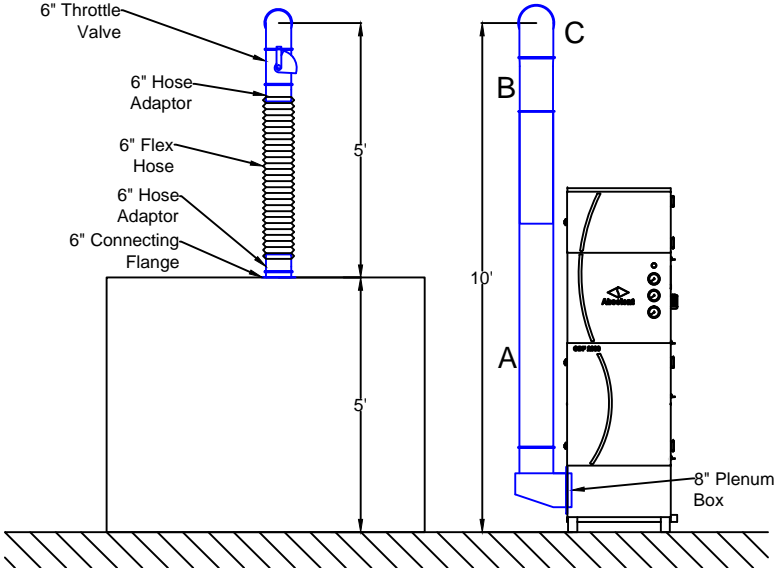
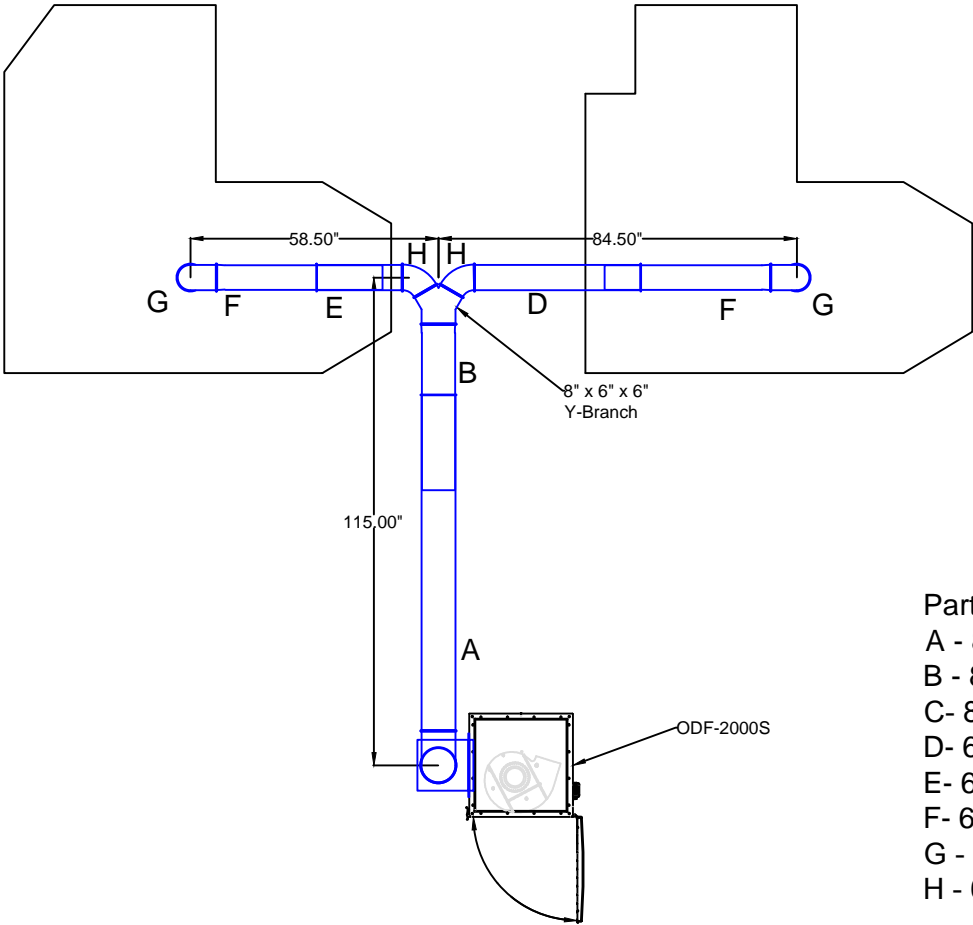

- Notes:
1. Jacobs tubing
 2. Connect to ODF-2000S

- Parts List
- A - 8" diameter 2000 tube
 - B - 8" diameter 1000 slip tube
 - C - 8" diameter 90° elbow
 - D - 6" diameter 1000 tube
 - E - 6" diameter 500 tube
 - F - 6" diameter 1000 slip tube
 - G - 6" diameter 90° elbow
 - H - 6" diameter 60° elbow

Avani Environmental Intl. 95 Cypress Drive Youngsville, NC 27596 P# 919-570-2862 F# 919-570-2863		
Project: Caterpillar Engine System Drawing: Duct Layout		
Date: 7/24/2013	Drawn by: MDT	
Sheet No: 1 Of 1		