

DRAWN BY	JX
DATE	3/16/15
CHKD BY	-
DATE	-
SHOP NO.	-
SCALE	1:45

REV	ECN	DATE	BY	CHK	DESCRIPTION
-	-	-	-	-	-
 <b>95 Cypress Dr. Youngsville, NC 27597 Phone: 919-570-2862 www.avanienvironmental.com</b>					
TITLE SDC-AT-5-40DD STAND					
DRAWING NO.		SHEET	ITEM	REV.	
BC 15753-002-00		1 OF 3	-	-	

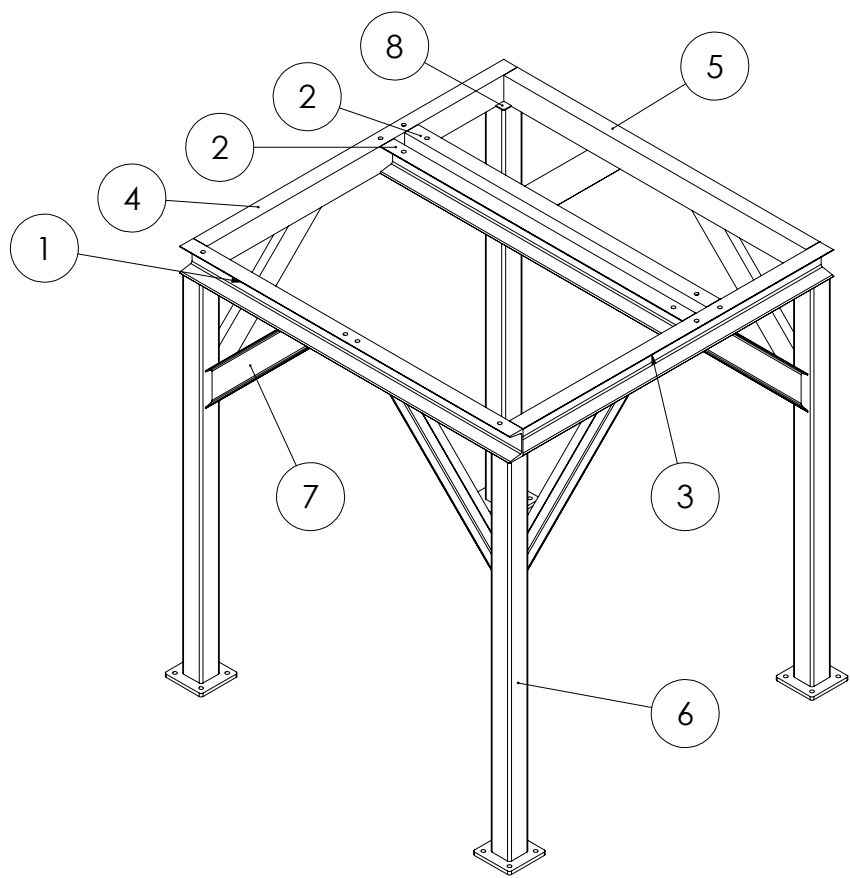

ITEM NO.	PART NUMBER	DESCRIPTION	QTY.
1	15753-002-01	MC 6X15.3 - 85.00 LONG	1
2	15753-002-02	MC 6X15.3 - 77.88 LONG	2
3	15753-002-03	MC 6X15.3 - 80.00 LONG	1
4	15753-002-04	MC 6X15.3 - 80.00 LONG	1
5	15753-002-05	MC 6X15.3 - 77.88 LONG	1
6	15753-002-09	LEG ASSEMBLY - 90.00 LONG	4
7	15753-002-07	C 6X8.2 - 40.00 LONG	8
8	15753-002-10	END CAP - 2.00X2.00X 7 GA	4

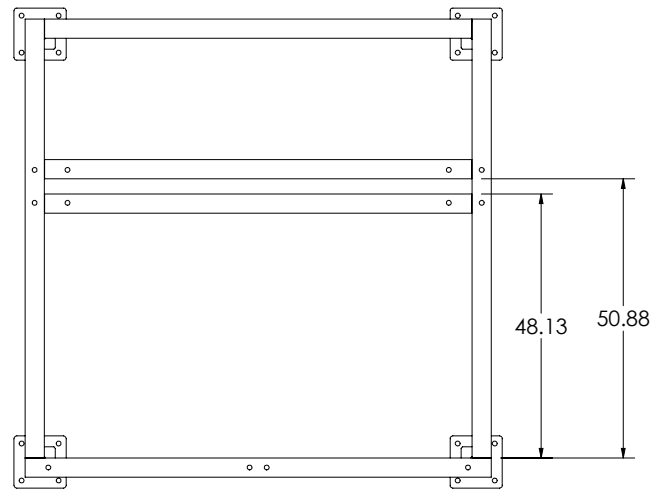
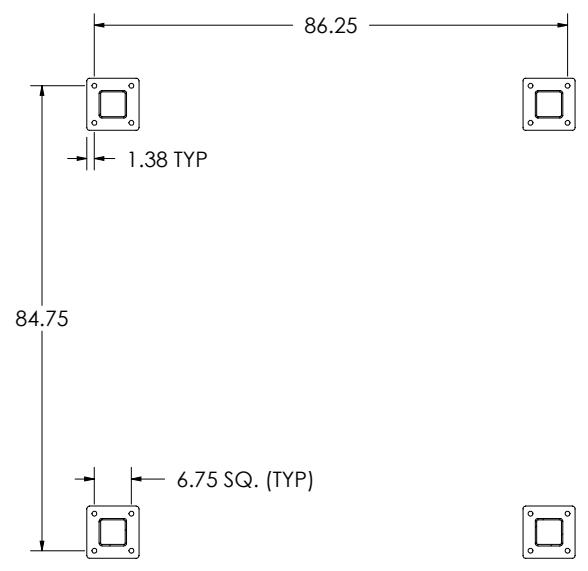

**SECTION A-A**

NOTES:

- MATERIAL: A36 OR EQUIVALENT

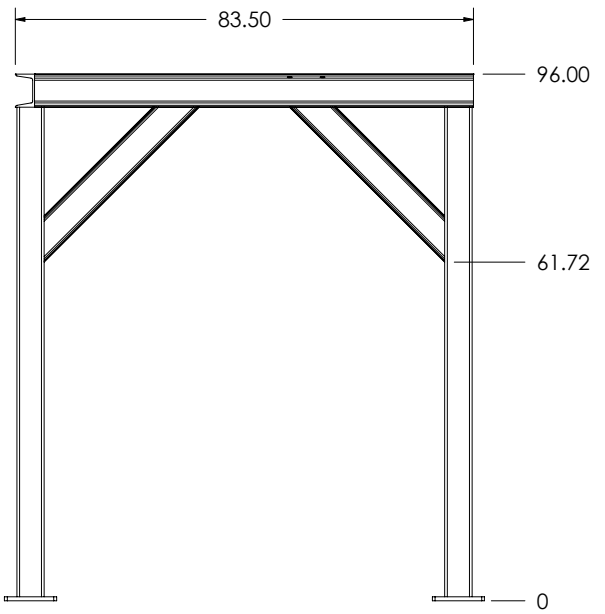
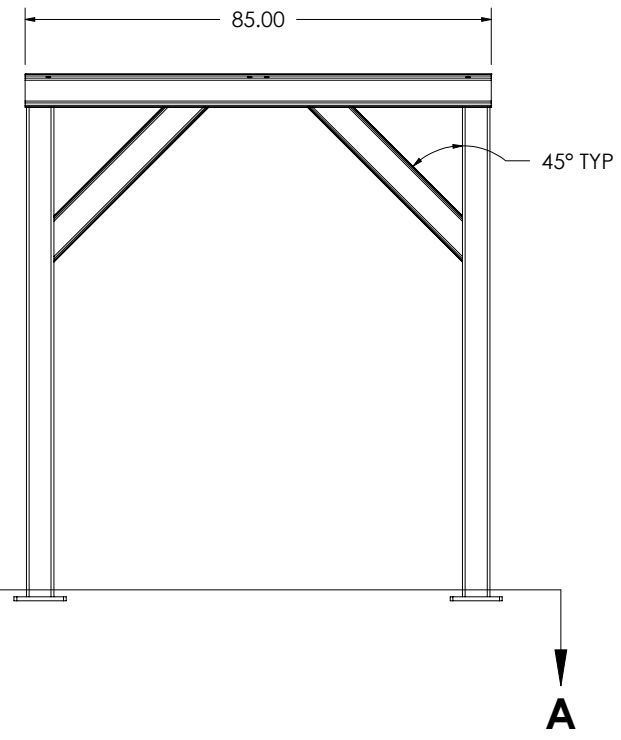

REV	ECN	DATE	BY	CHK	DESCRIPTION
-	-	-	-	-	-



**95 Cypress Dr.  
Youngsville, NC 27597  
Phone: 919-570-2862  
www.avanienvironmental.com**

TITLE: SDC-AT-5-40DD STAND

DRAWING NO.	SHEET	ITEM	REV.
BC 15753-002-00	2 OF 3	-	-

DRAWN BY	JX
DATE	3/16/15
CHKD BY	-
DATE	-
SHOP NO.	-
SCALE	1:35

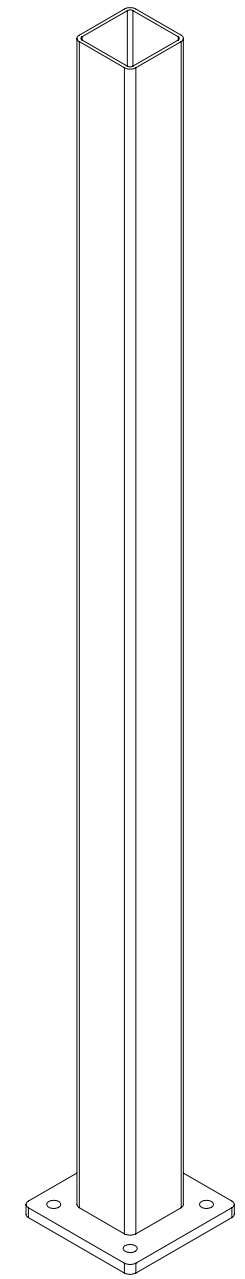
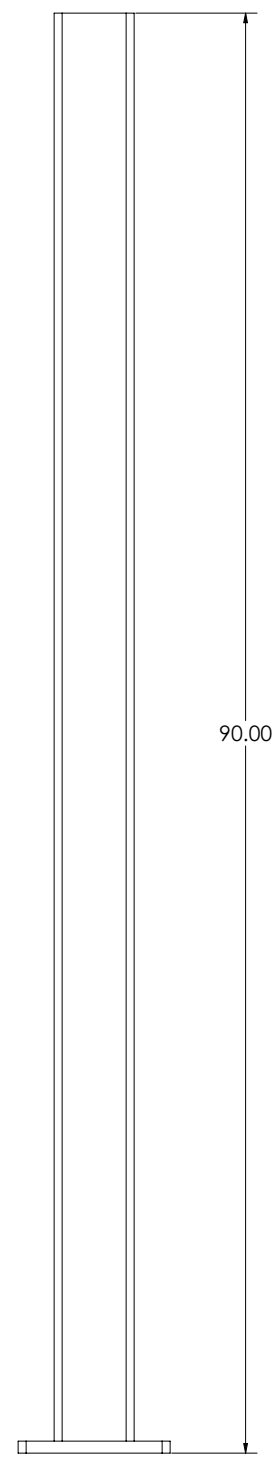
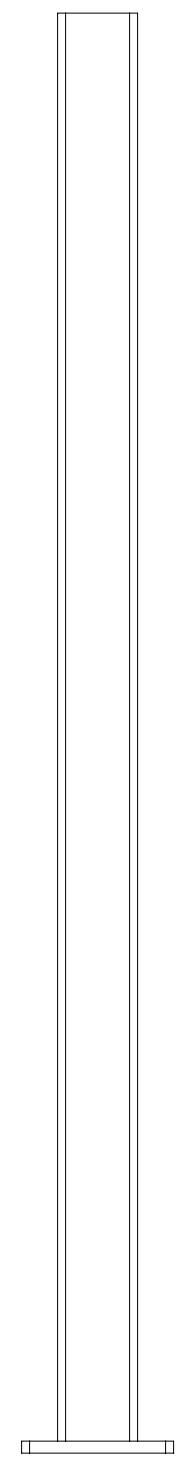
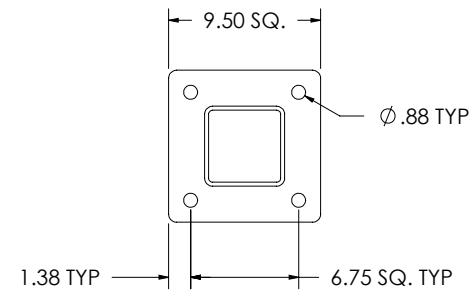
ITEM NO.	PART NUMBER	DESCRIPTION	QTY.
1	15753-002-06	SQ. TUBING - 5.00X5.00X0.25 (89.25 LONG)	1
2	15753-002-08	LEG BASE PLATE - 9.50X9.50X0.75	1



REV	ECN	DATE	BY	CHK	DESCRIPTION
-	-	-	-	-	-

DRAWN BY JX DATE 3/16/15 CHKD BY - DATE - SHOP NO. - SCALE 1:12			95 Cypress Dr. Youngsville, NC 27597 Phone: 919-570-2862 www.avanienvironmental.com		
	TITLE				
	SDC-AT-5-40DD STAND				
	LEG ASSEMBLY				
	DRAWING NO.		SHEET	ITEM	REV.
BC 15753-002-09		3 OF 3	-	-	