

DO NOT SCALE

IF IN DOUBT ASK

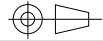

Revisions

Rev	Description	Date	Approved
-----	-------------	------	----------

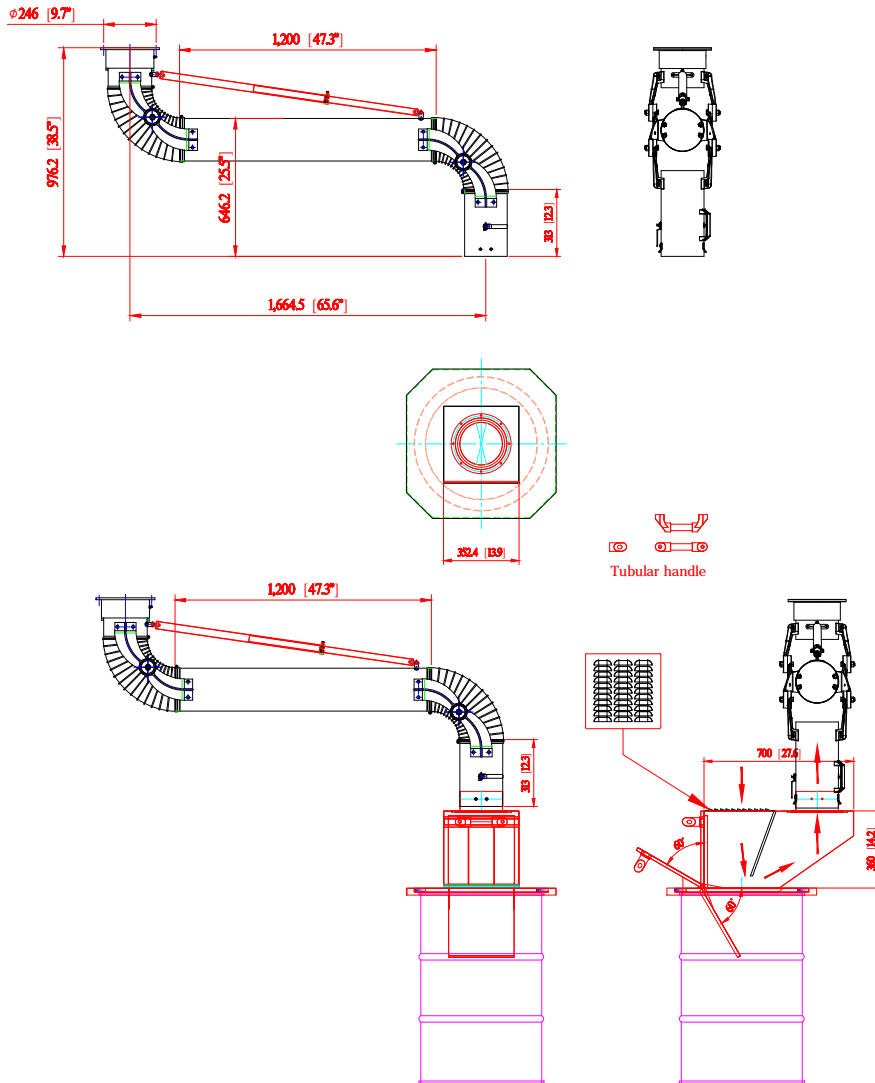

# Hanging Arm 5" \* 5' with 55 gallon drum

Diameter: 8"

Length: 5'

Weight: 50 lbs (net)

Arm Construction: Two galvanized steel tubes, powder coated, (2) die casted aluminum external joints, heavy gauge steel swivel base, steel final external joint with aluminum hood, 360 degree grab handle, and support spring in protective aluminum cover.

Arm Adjustment: 100% externally supported (no internal joints).

Damper: Internal damper with external adjustment.

Finish: Powder coated.

External Hose: Smooth bore, helical hose rated at 200 degrees.

Finish: Powder coated. Off-white.

Accessories: Mounting bracket

55 Gallon Drum: shown for reference purposes only. Not included/provided.

Warranty: Limited two years from date of purchase.

AVANI ENVIRONMENTAL INTL. INC. Sales Department  
 95 Cypress Drive (919) 570-2862  
 Youngsville, NC 27596 info@avanienvironmental.com

Drawn by:	Date	Name	Part Number:	Title:
Checked by:	2014-08-11	***	**	Arm 2020P with Barrel top
The drawings, AutoCAD, 3-D Models, and specifications are the property of Avani Environmental Intl. Inc. (AE) and may not be reproduced, distributed, modified, or otherwise used, except provided herein, without the express written permission of AE.				Size <b>A</b> Scale 1 = xx Drawing Number: ARM 2020P w/Barrel top