



Date: August 16, 2011

Project: assembly procedure

To: Amtrak Seattle

Attn:

Recommended Equipment:

(1) WB-18x10P Welding Booth: 18'W x 10'D

- 34" width hood

- (2) Ø8" x 14' Hanging Fume Arm + oversize hood dia. 39.4"

- swing out doors

(2) 7.5HP blowers top mounted:

- Cincinnati fan to source locally

Avani Environmental Intl. Inc.

95 Cypress Drive

Youngsville, NC 27596

www.avanienvironmental.com

Phone: (919) 570-2862

Fax: (919) 570-2863

Email: info@avanienvironmental.com

www.weldingbooths.com

The drawings, AutoCAD, 3-D Models, and specifications are the property of Avani Environmental Intl. Inc. (AE) and may not be reproduced, distributed, modified, or otherwise used, except provided herein, without the express written permission of AE.

**Amtrak
Seattle**

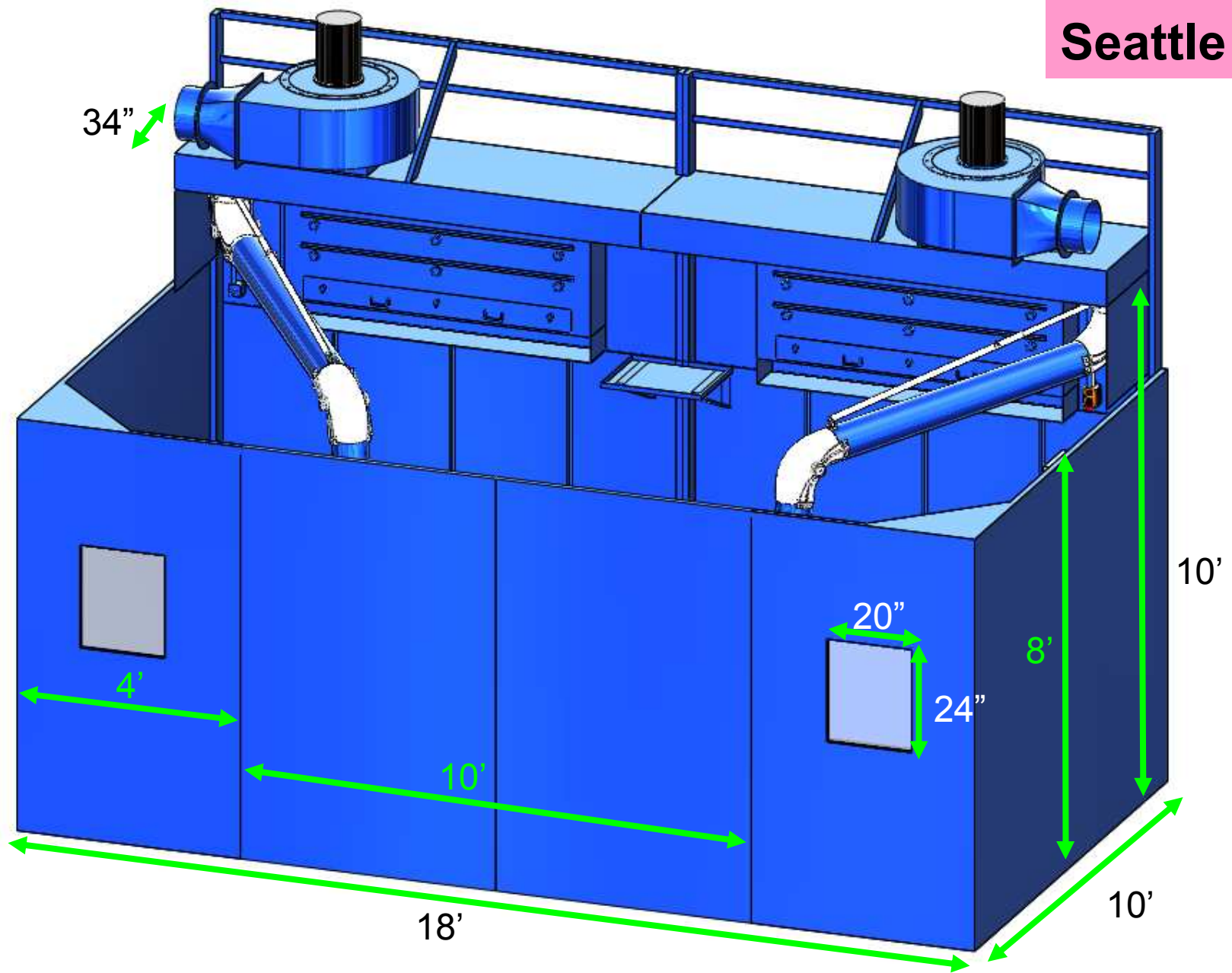

How to assemble:

- backdraft module
- air compressor connection

- (2) light switches: 110V, for overhead lights
- (2) lights

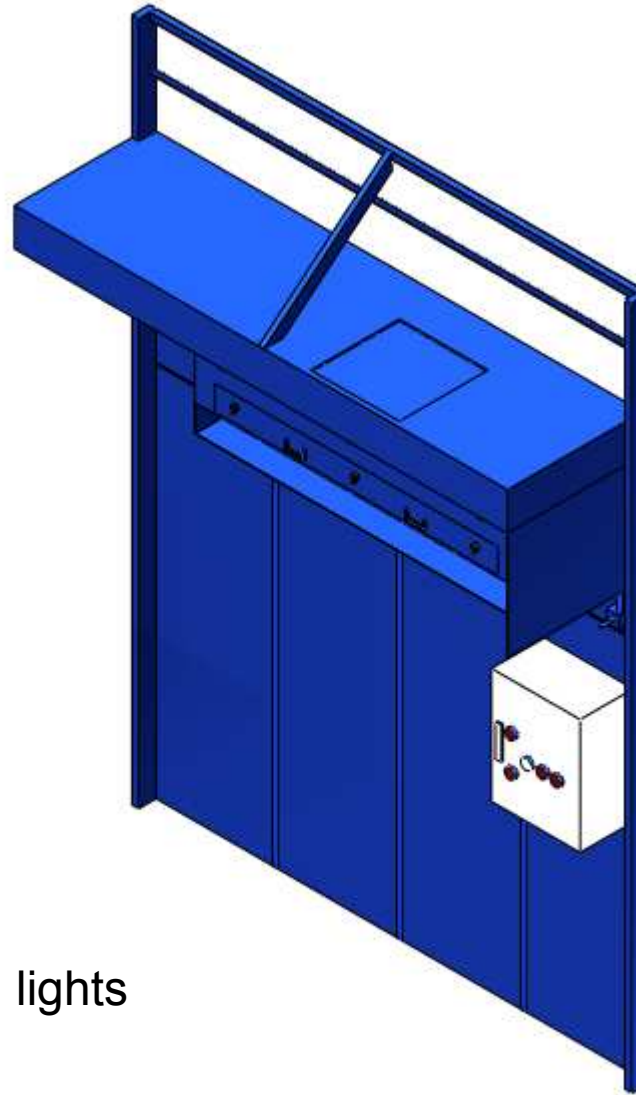

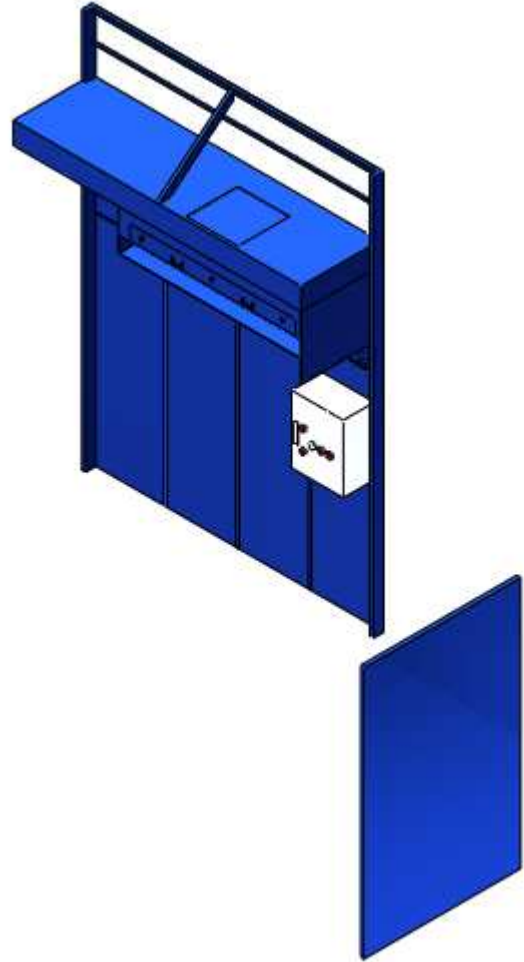



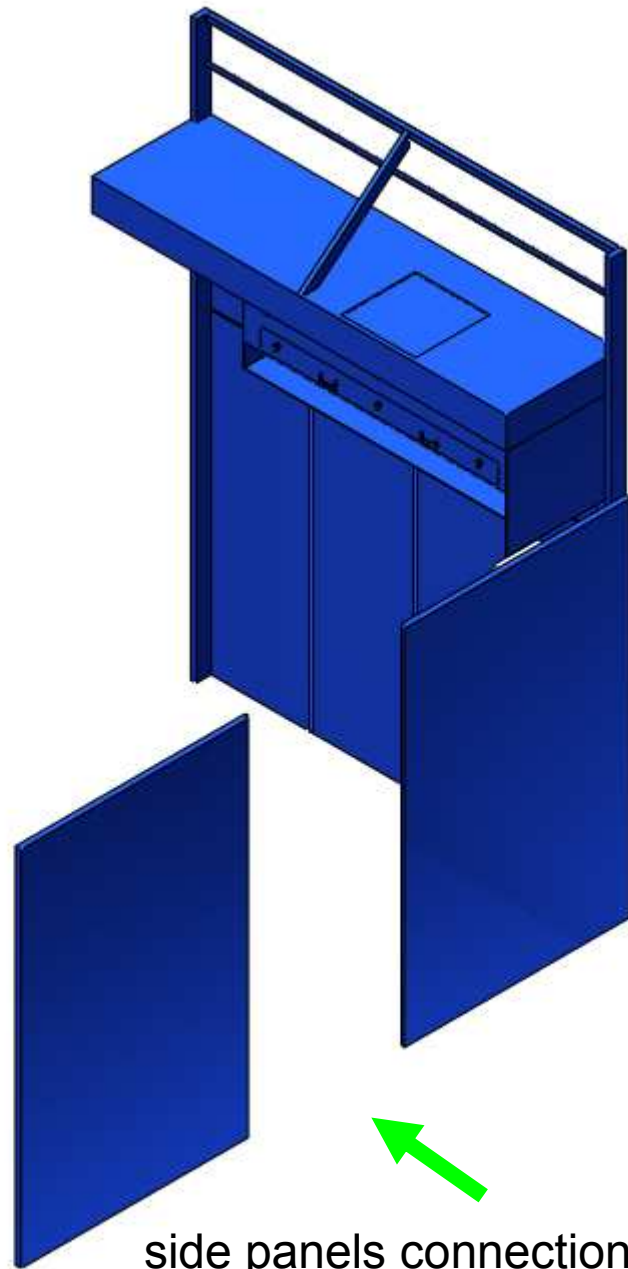

side panels connection

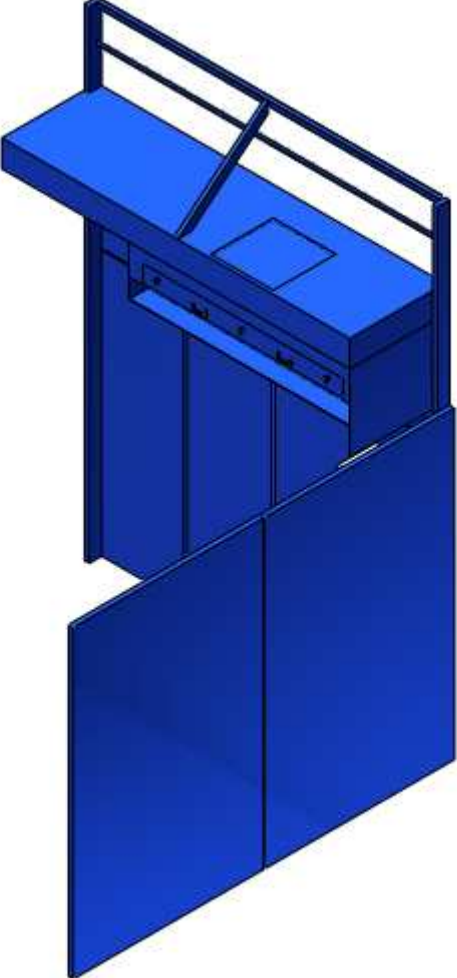

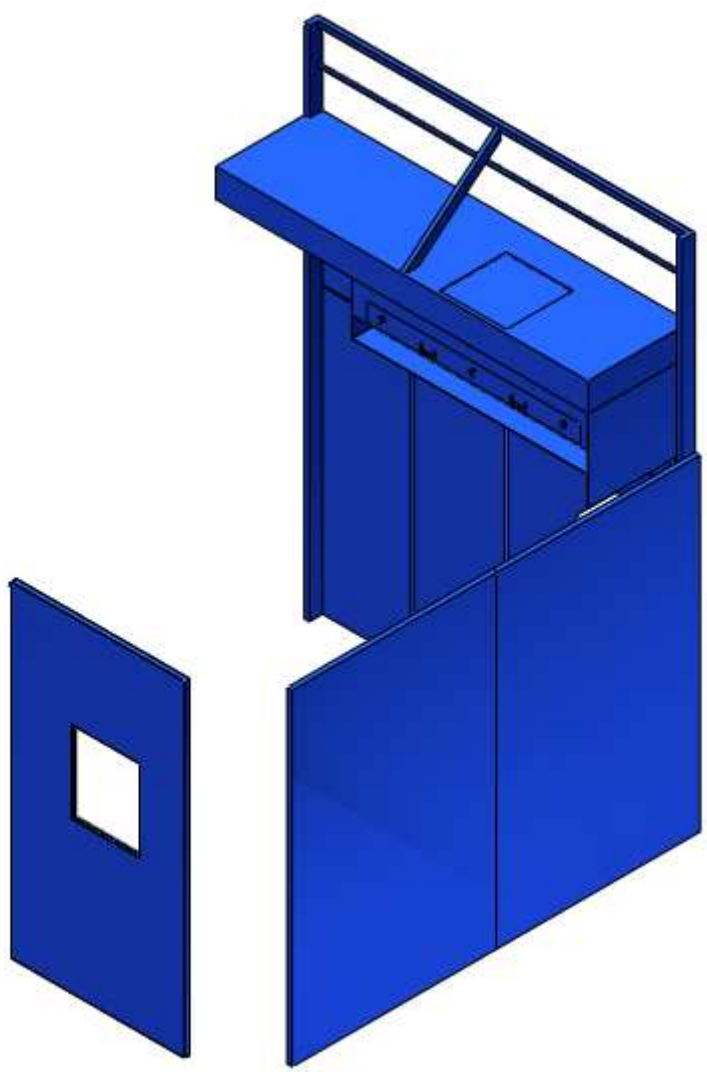

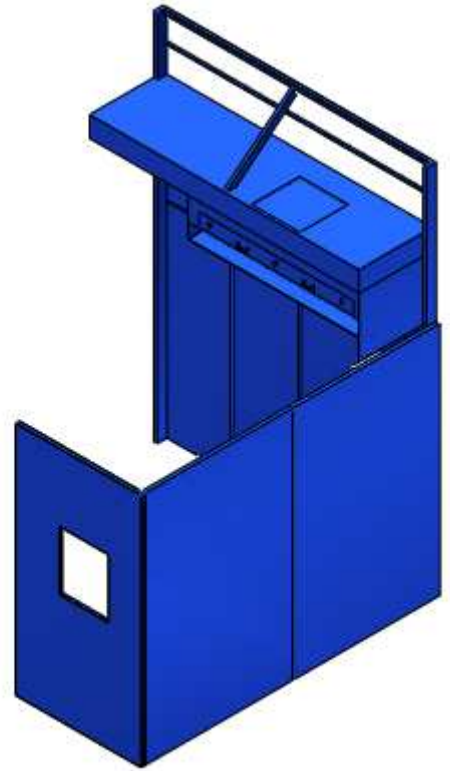

front panel

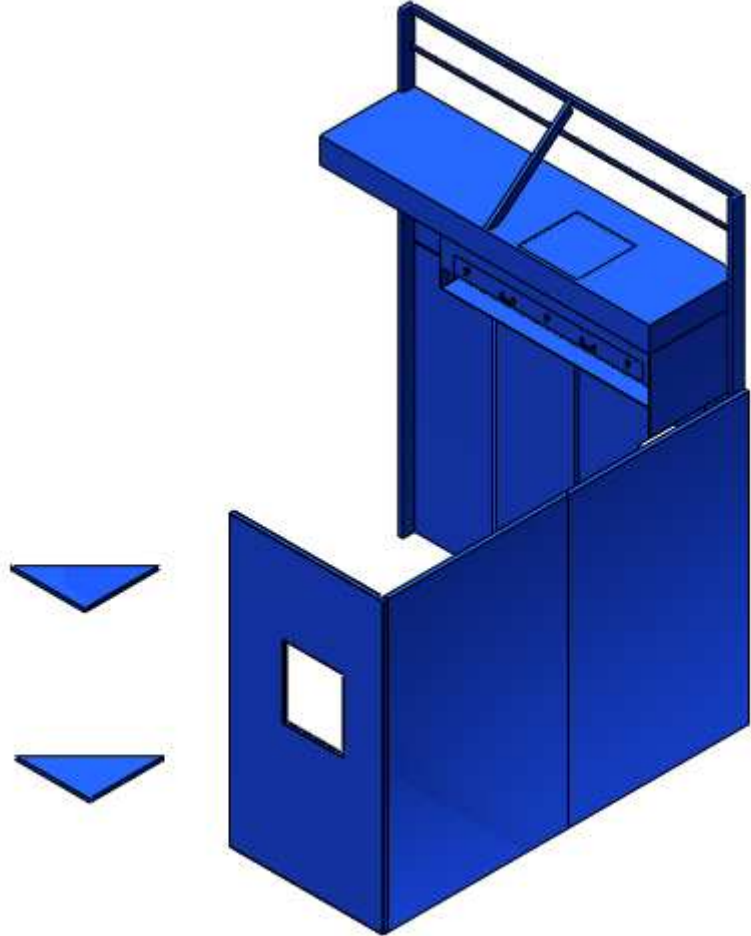

gussets for support

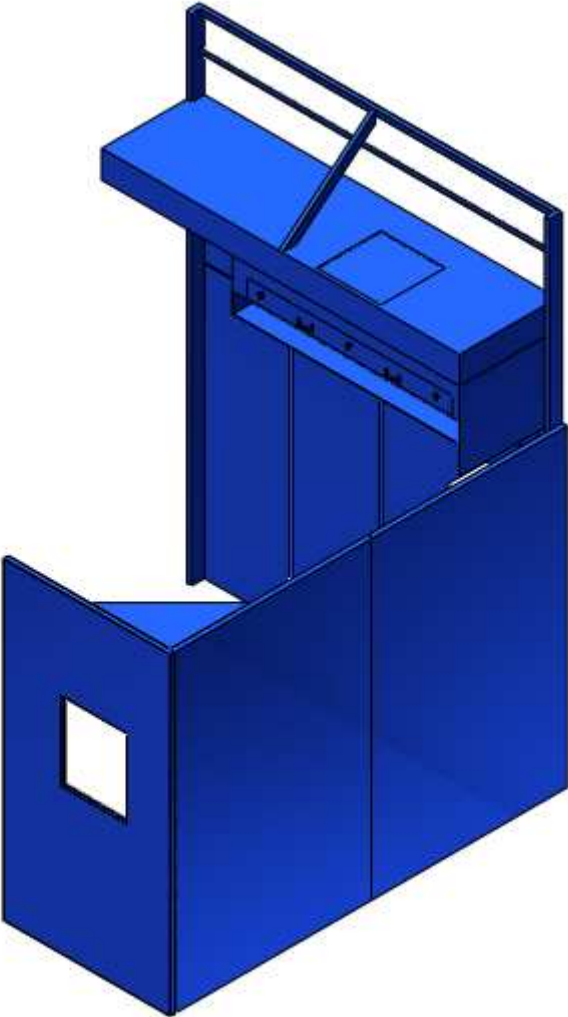

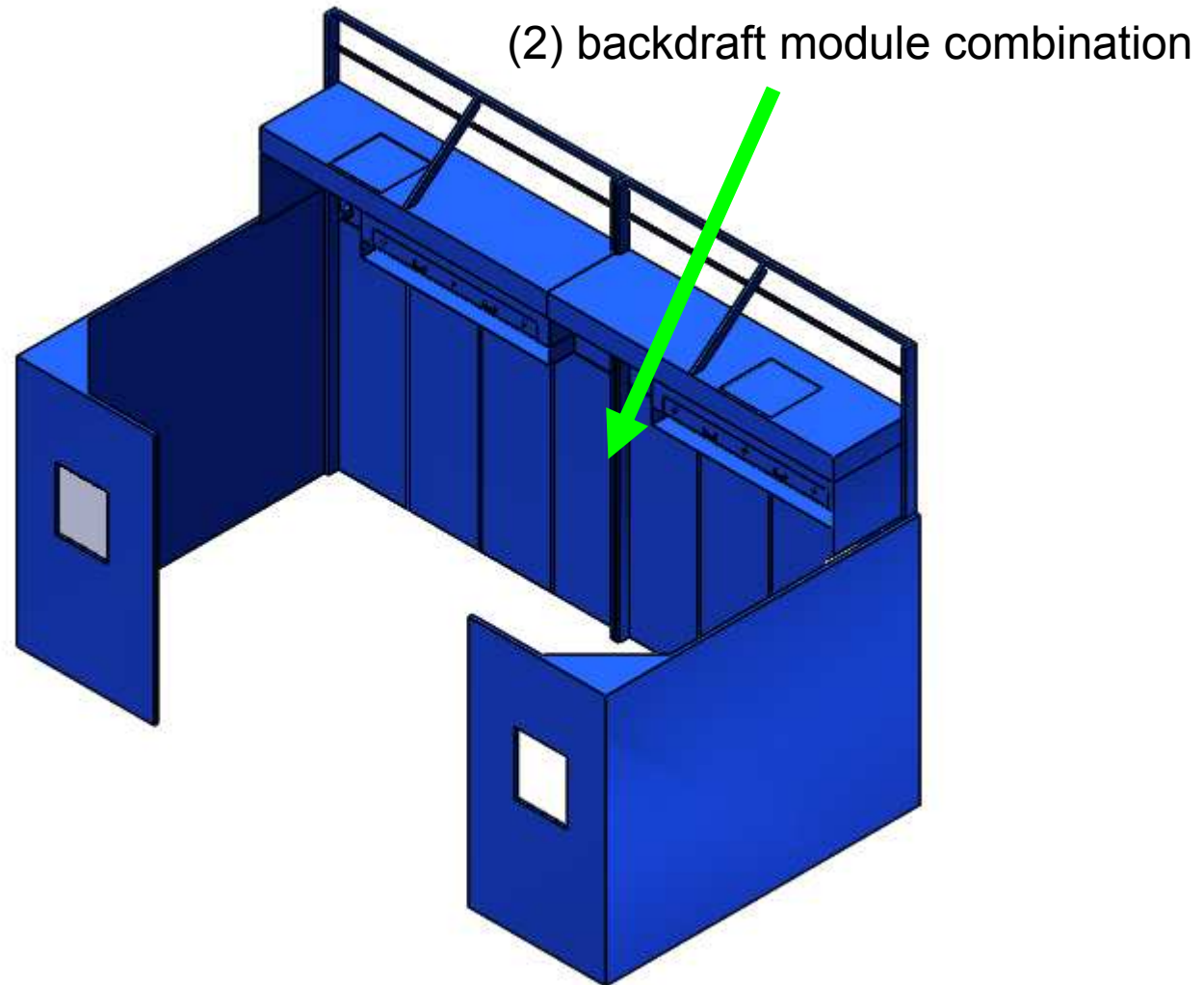

same process for left side of the booth

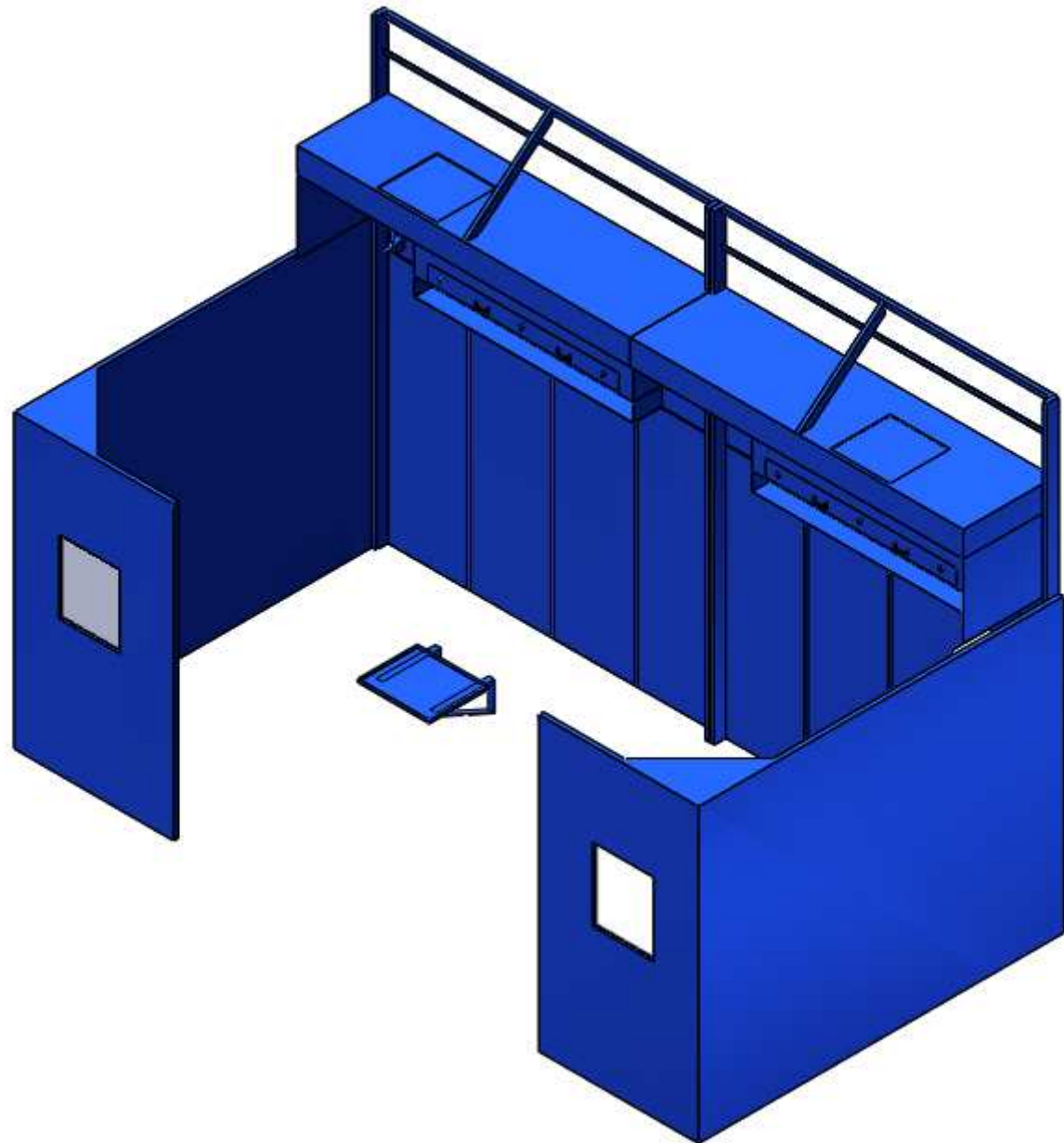

CO2 bracket

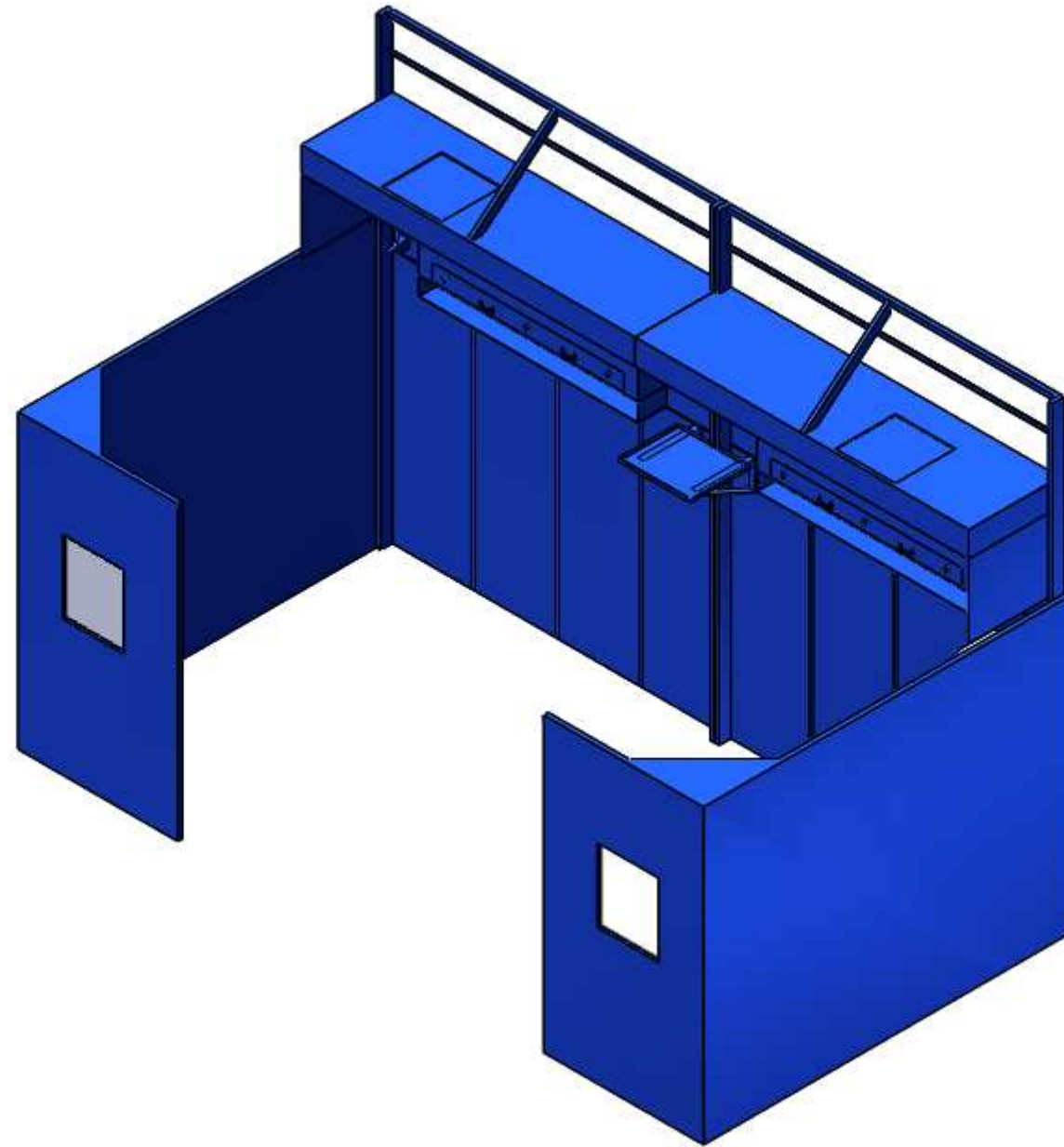

recessed lights

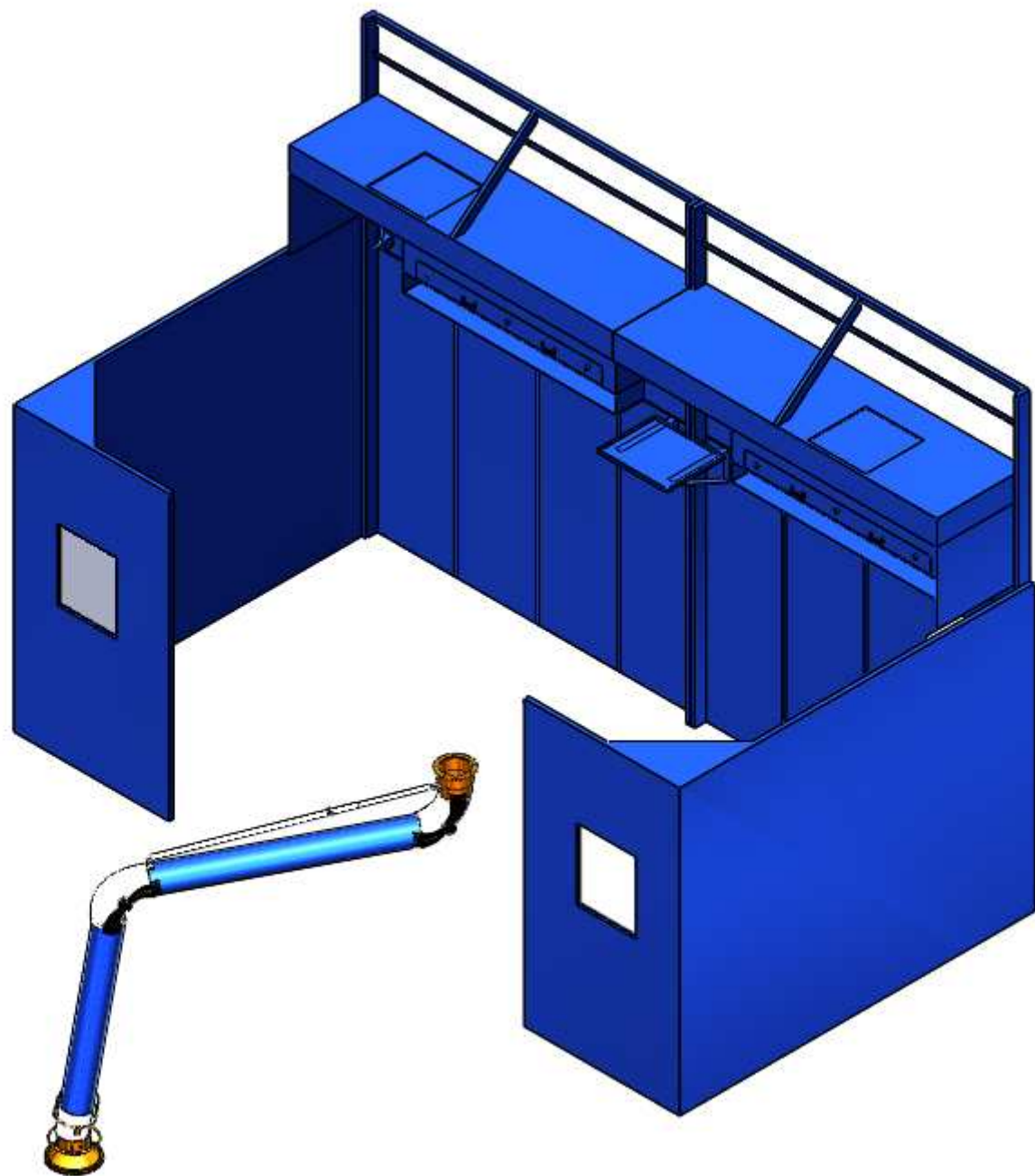

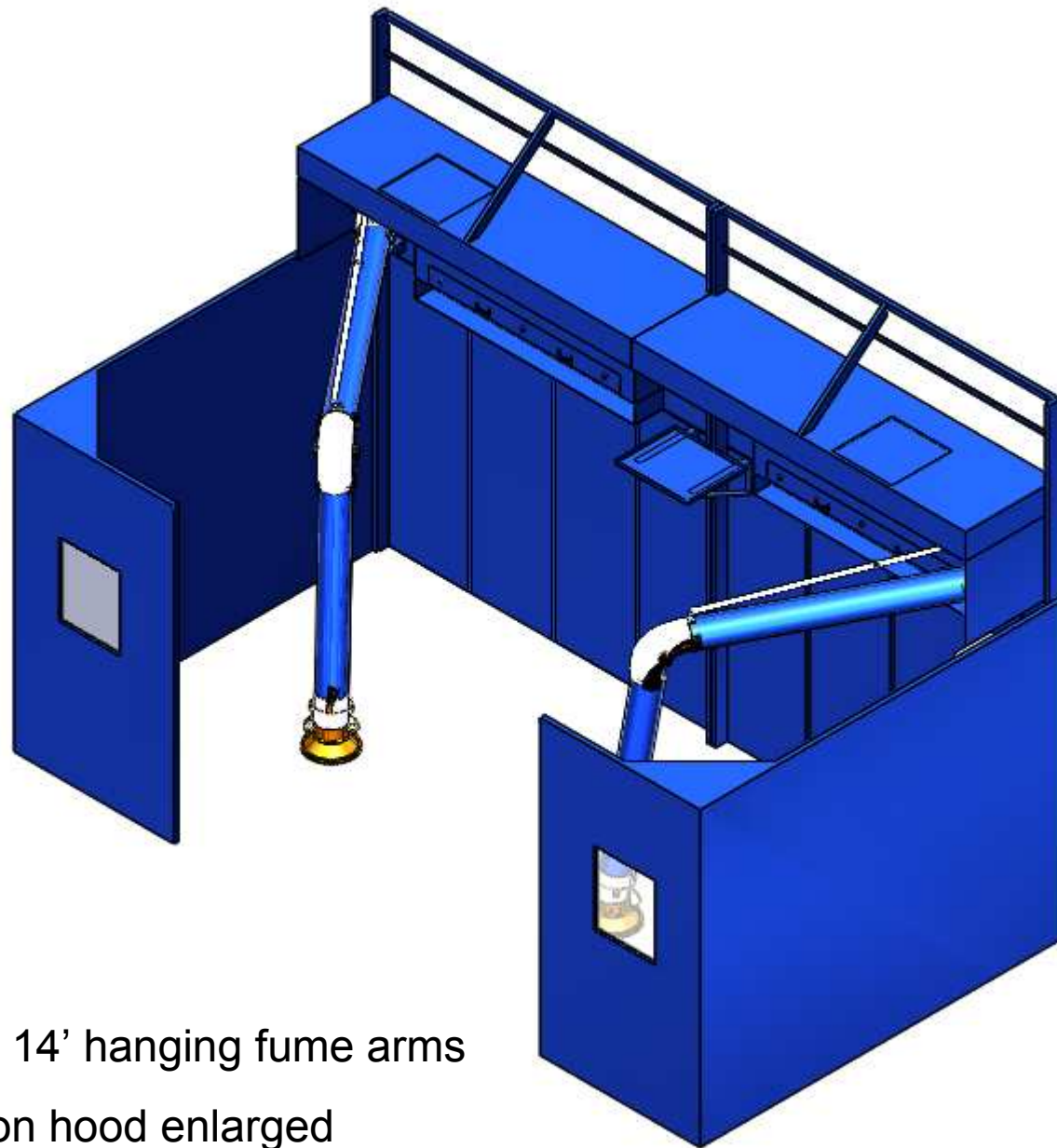

- (2) pcs of Ø 8" x 14' hanging fume arms
- size of the suction hood enlarged

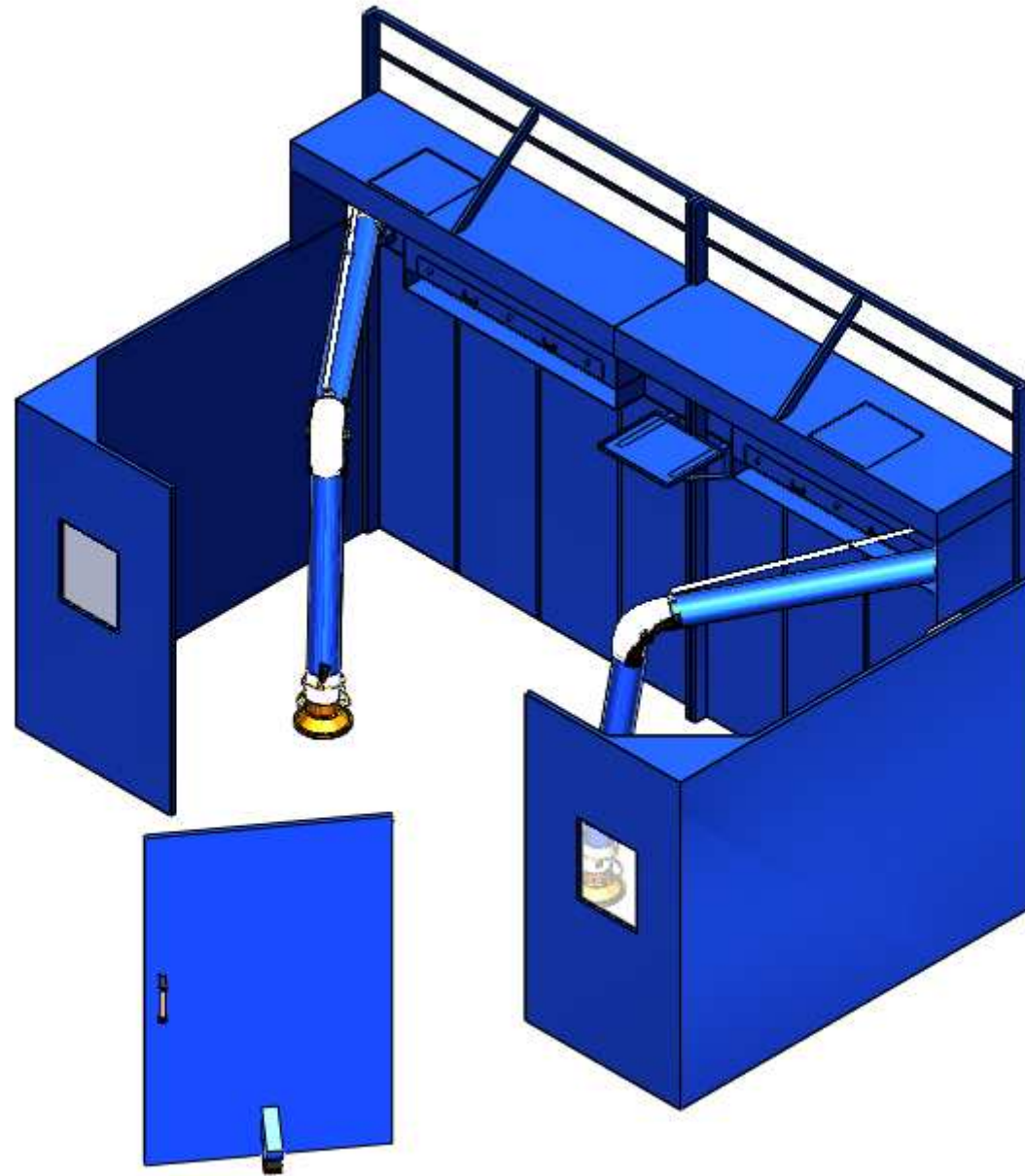

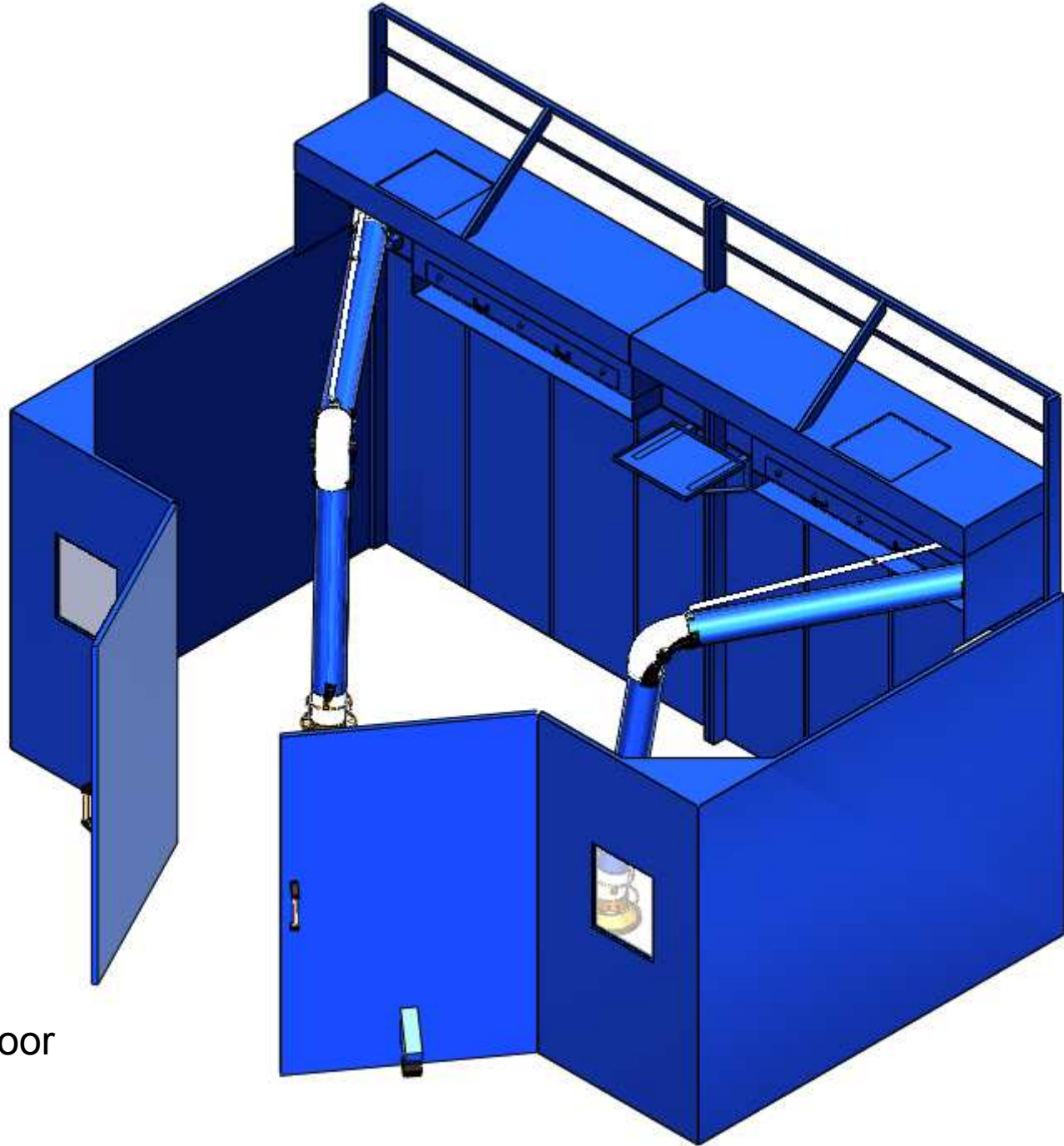

swing out door

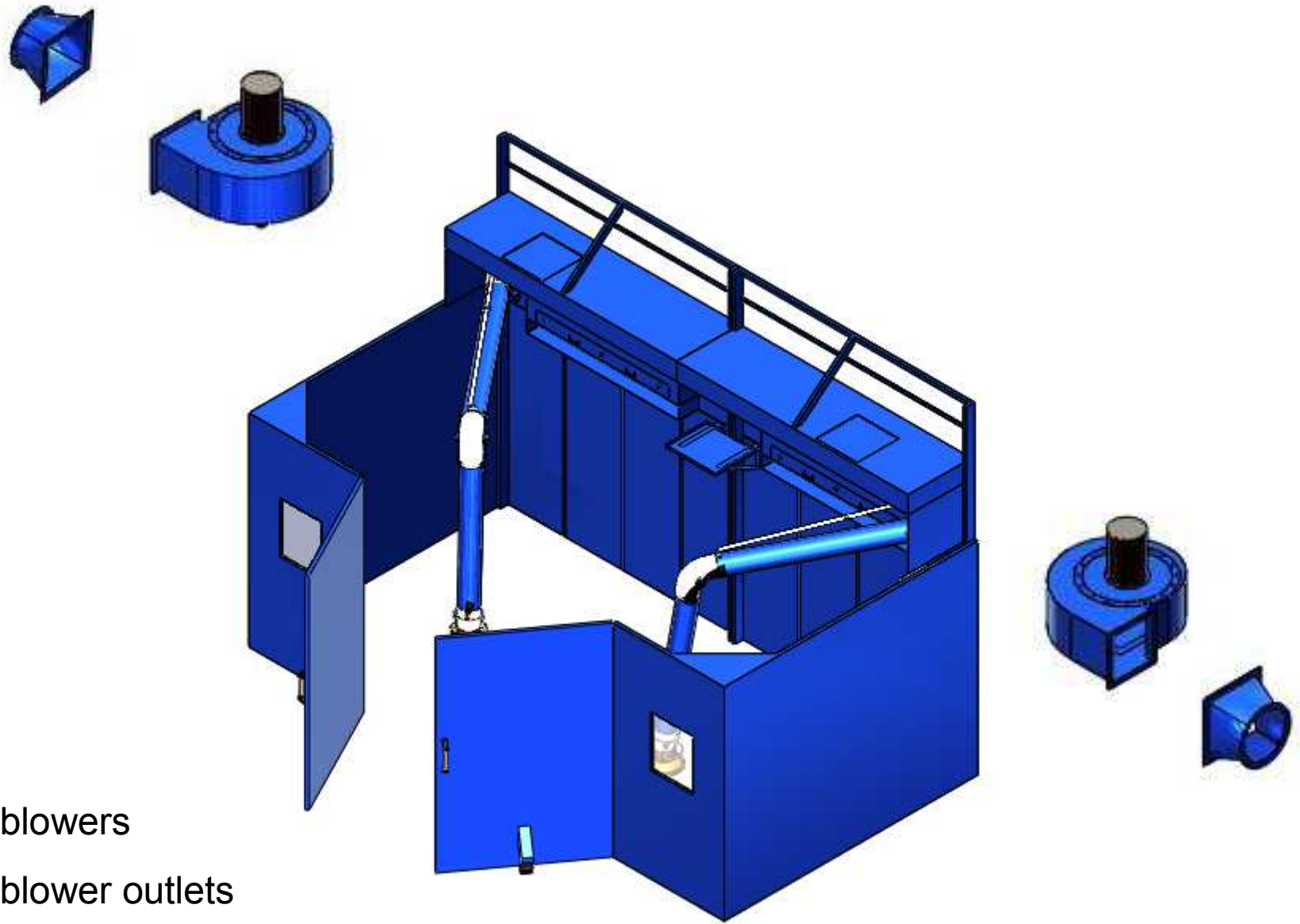

- blowers
- blower outlets

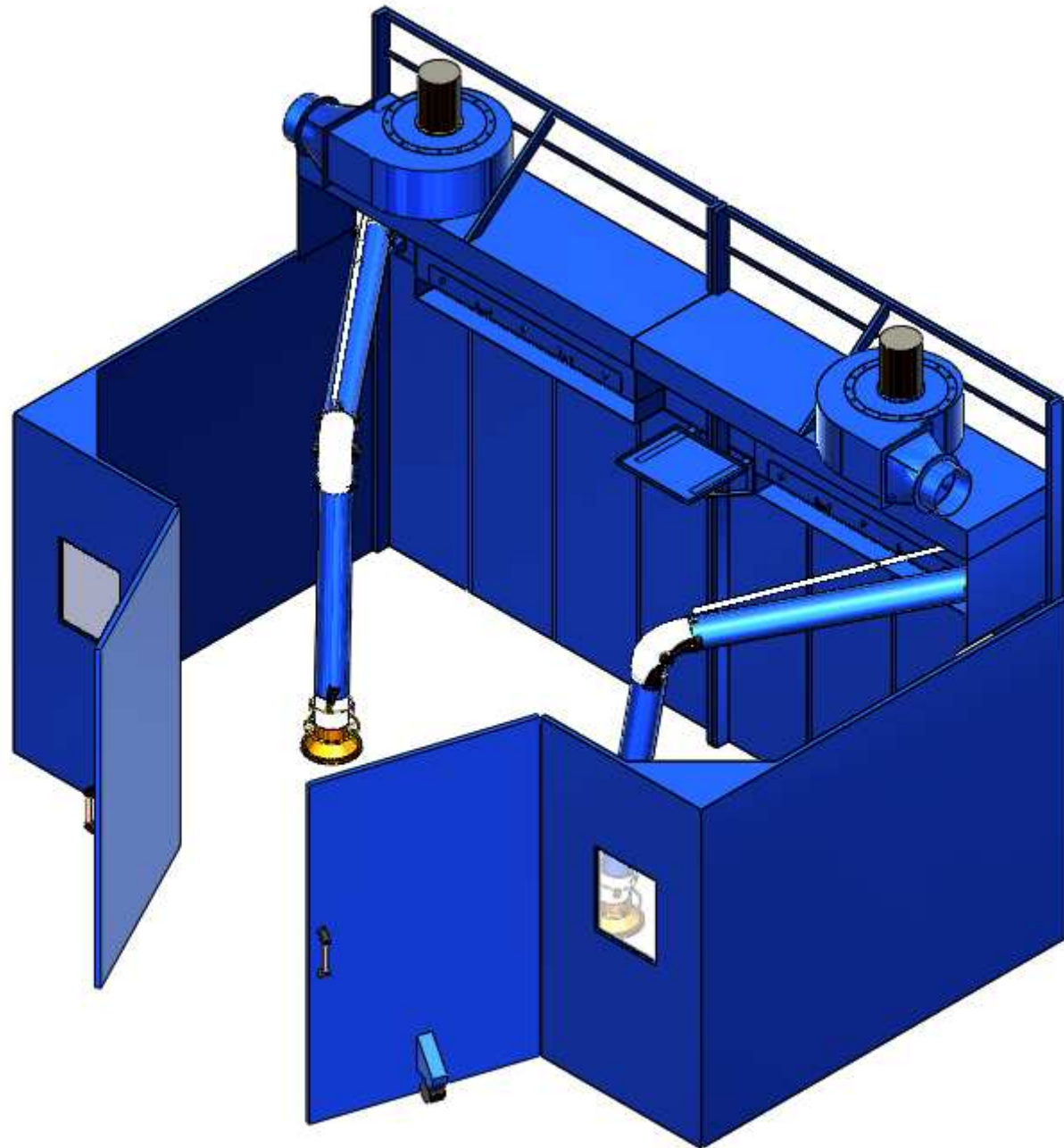

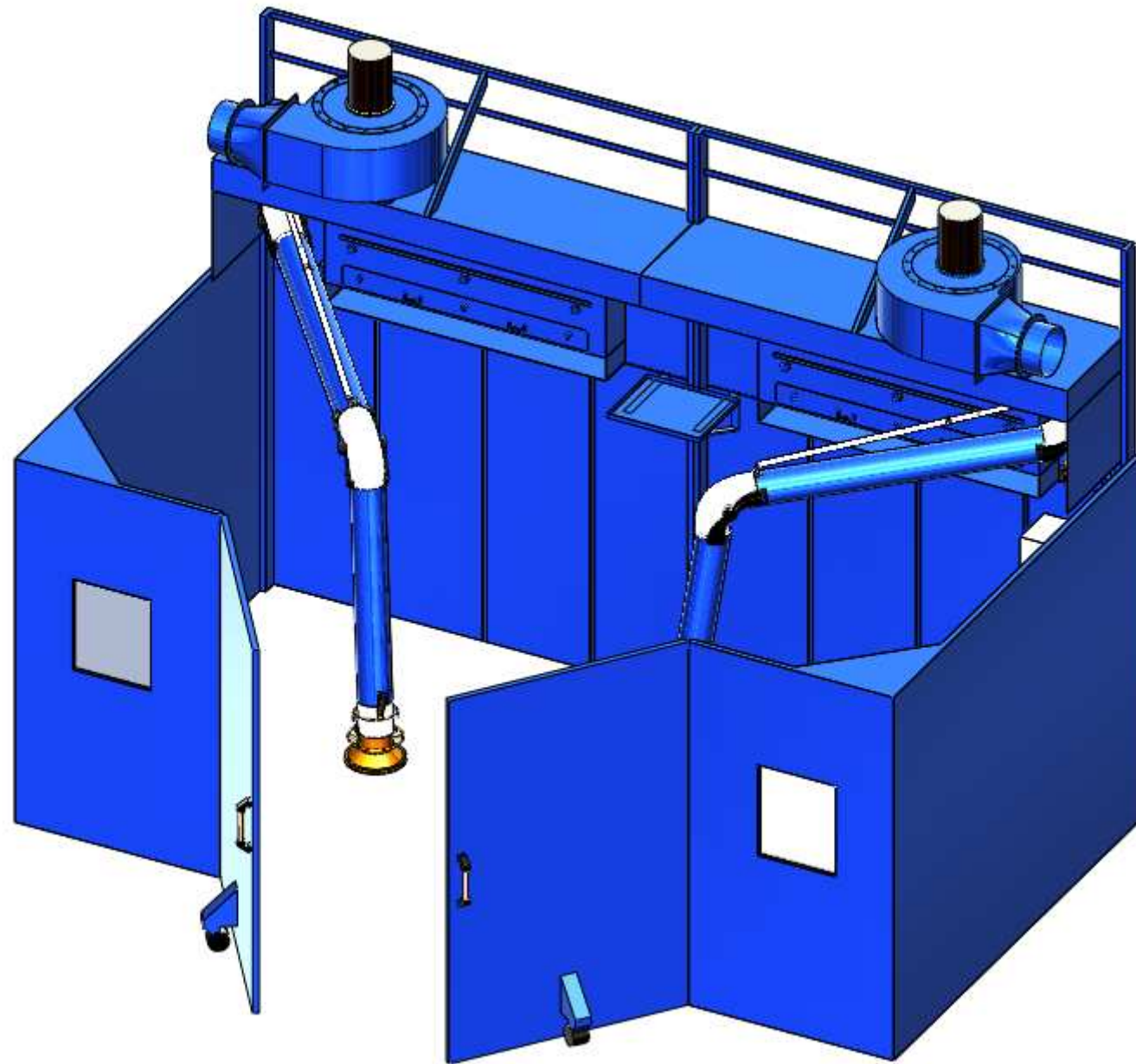

Assembly completed.