

Connection to the Compactor

Side View

Cover top opening with aluminum panel
39" x 8-1/2"

Back Side of Compactor

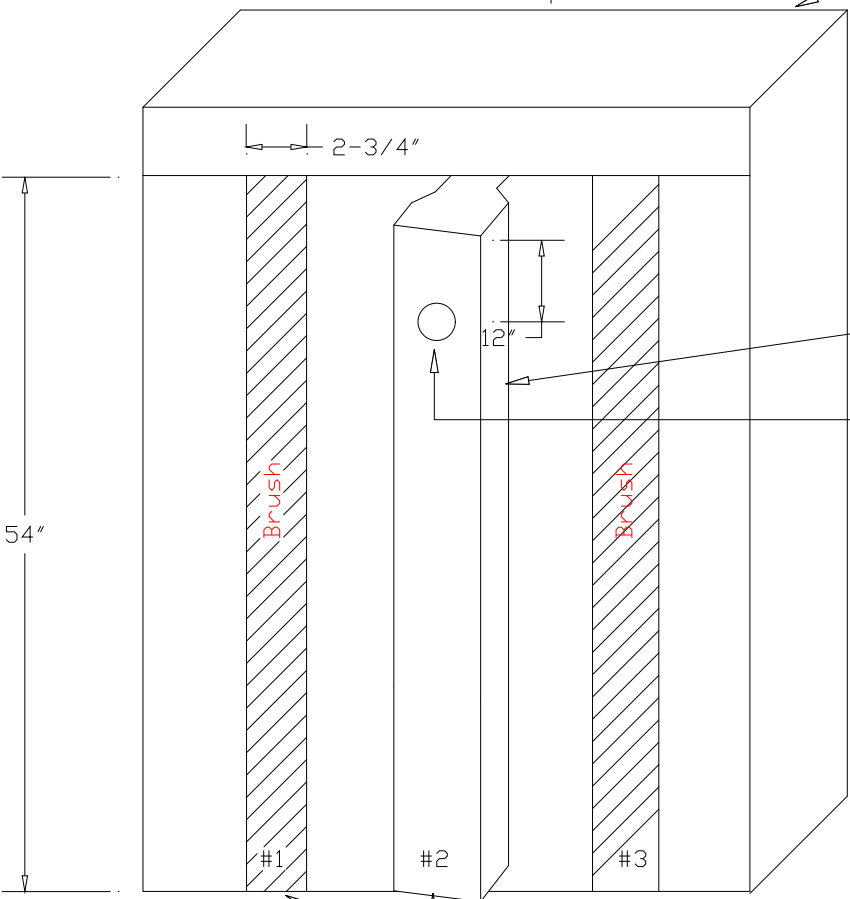

Notes:

- 1) Brush will cover the gap on slots #1 & #3
- 2) Cover top opening with aluminum plate
- 3) Slot #2 will have hood covering top to bottom
- 4) Attach the hood with pop rivets
- 5) Attach the brushes with pop rivets

Hood

6" 90 deg elbow welded to back of hood

Three slots 2-3/4" wide x 54" high

Industrial Air Quality		IAQ
102 AG DRIVE		
Youngsville, NC 27596		
P# 919-562-7181 F# 919-562-7182		
Project: AD Smith		
Drawing: Conn to Compactor		
Date: 9/27/07	Drawn by: DOJ	
Revision Date:		

Connection to the Compactor

Side View

Back Side of Compactor

Cover top opening with aluminum panel
39" x 8-1/2"

Notes:

- 1) Brush will cover the gap on slots #1 & #3
- 2) Cover top opening with aluminum plate
- 3) Slot #2 will have hood covering top to bottom
- 4) Attach the hood with pop rivets
- 5) Attach the brushes with pop rivets

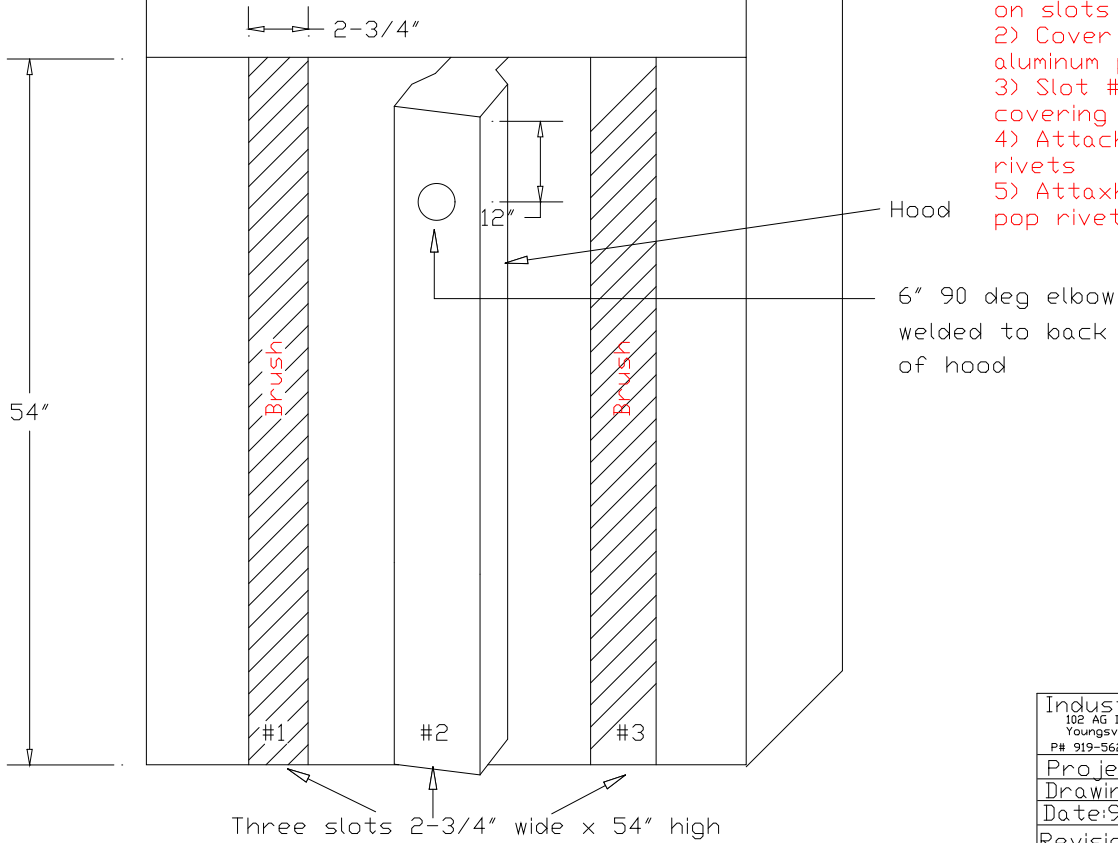

Industrial Air Quality		IAQ
102 AG DRIVE Youngsville, NC 27596		
PH 919-562-7181 F# 919-562-7182		
Project: A Smith		
Drawing: Conn to Compactor		
Date: 9/27/07		Drawn by: DDJ
Revision Date:		