

DO NOT SCALE

IF IN DOUBT ASK



Revisions

Rev	Description	Date	Approved
-----	-------------	------	----------

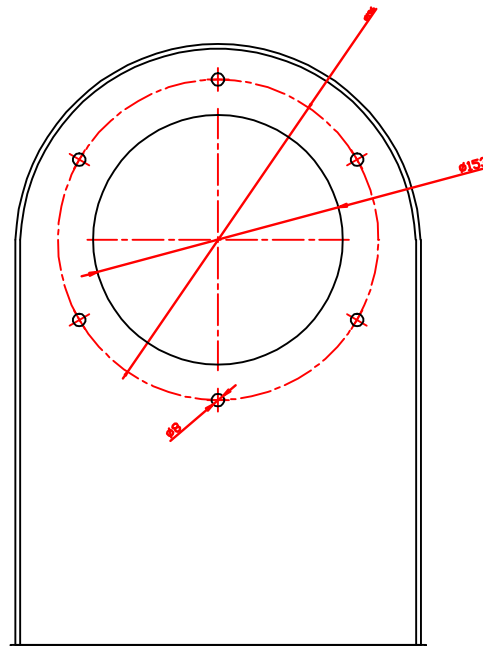
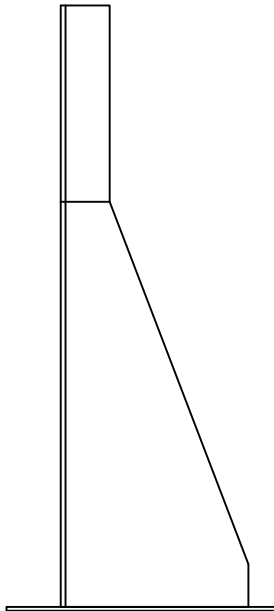
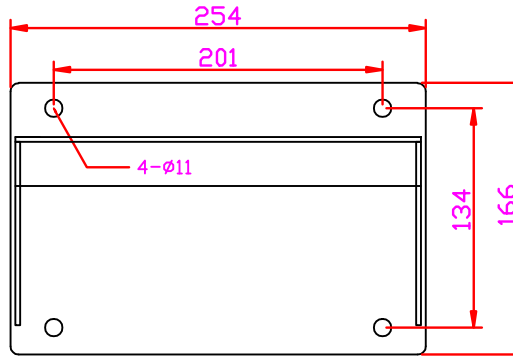

AVANI ENVIRONMENTAL INTL. INC. Sales Department

95 Cypress Drive  
Youngsville, NC 27596

(919) 570-2862  
info@avanienvironmental.com

Drawn by:	Date	Name
***	2009-11-19	***
Checked by:		

Part Number:  
FE-MB-6

Title:  
6inch arm swivel base bolt pattern

The drawings, AutoCAD, 3-D Models, and specifications are the property of Avani Environmental Intd. Inc. (AE) and may not be reproduced, distributed, modified, or otherwise used, except provided herein, without the express written permission of AE.

Size  
A

Scale  
1 = 1

Drawing Number:  
FE-MB-6