

18" Plenum Box For A*Mist 80TF (JT or K&B)

TOP VIEW

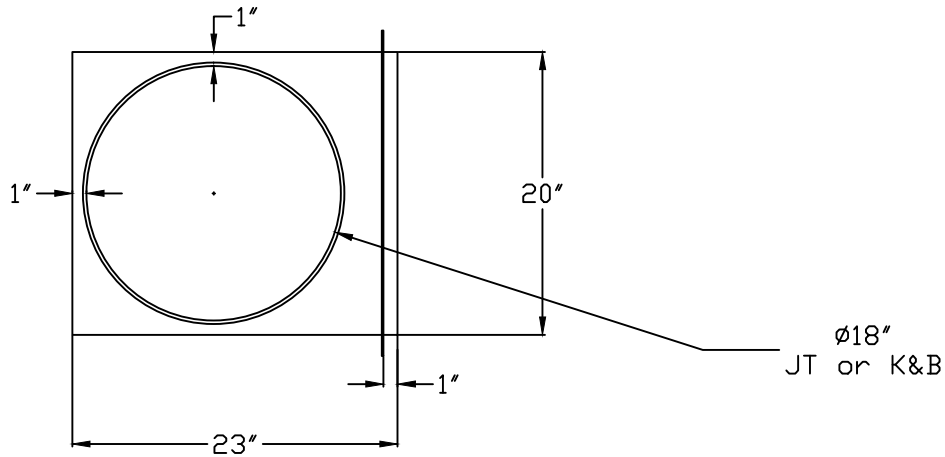

NOTES:

- A) MATERIAL: 18 GA. GALV.
- B) ALL SEAMS WELDED
- C) Use standard bolt hole pattern with 7/16" Holes

SIDE VIEW

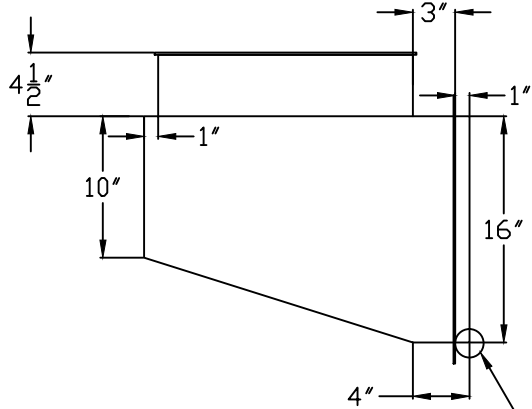

END VIEW

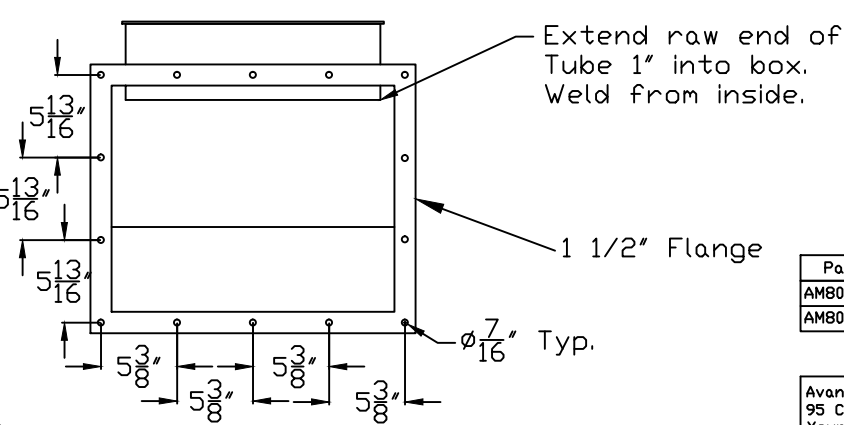

NOTE: WELD ALL CORNERS ON BOTTOM
INSIDE THE PLENUM!!!!

Part No:
AM80-18-JT-PB
AM80-18-KB-PB

Avani Environmental Intl.
95 Cypress Drive
Youngsville, NC 27596
P# 919-570-2862 F# 919-570-2863

Avani

Project: Absolent Plenum Boxes	
Drawing: AM80-18-PB	
Date: 4/9/15	Drawn by: WWB
Sheet No: 1 of 1	Rev.: A