

16" Plenum Box  
For A\*Mist 80TF  
(JT or K&B)

TOP VIEW

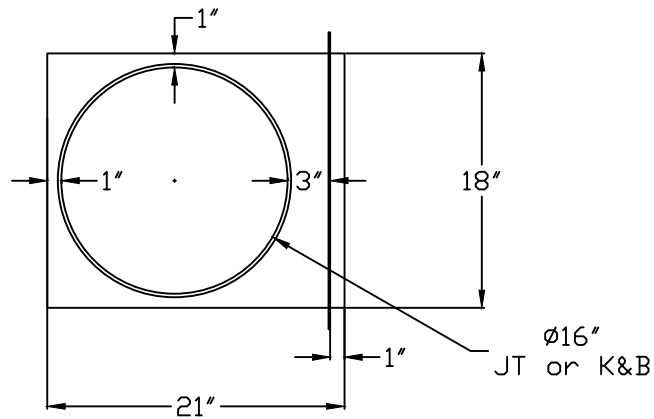

- NOTES:  
 A) MATERIAL: 18 GA. GALV.  
 B) ALL SEAMS WELDED  
 C) Use standard bolt hole pattern with 7/16" Holes

SIDE VIEW

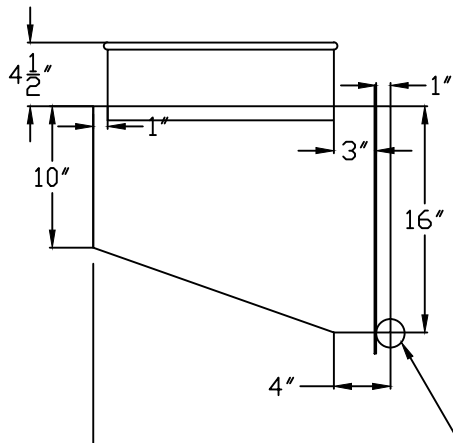

END VIEW

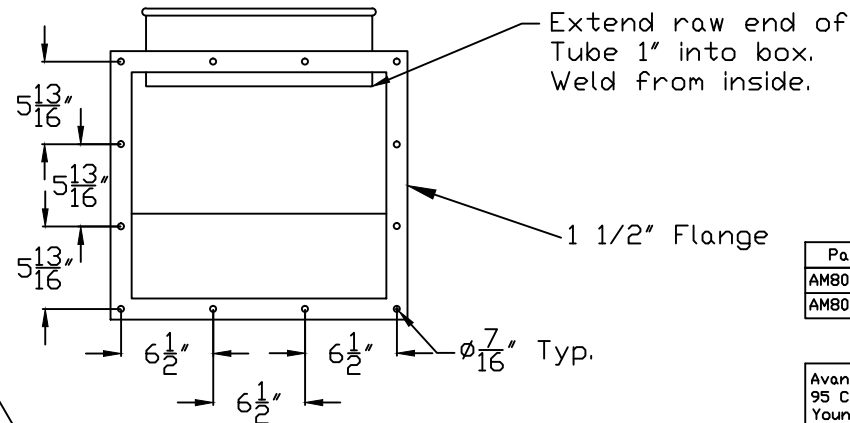

NOTE: WELD ALL CORNERS ON BOTTOM INSIDE THE PLENUM!!!!

Part No:
AM80-16-JT-PB
AM80-16-KB-PB

Avani Environmental Intl.  
 95 Cypress Drive  
 Youngsville, NC 27596  
 P# 919-570-2862 F# 919-570-2863

**Avani**

Project: Absolent Plenum Boxes	
Drawing: AM80-16-PB	
Date: 4/9/15	Drawn by: WWB
Sheet No: 1 of 1	Rev.: A